

Controlled Document
Confirm revision before using

EOS
www.eostech.com

EOS Technologies, Inc.

**AUTOMATED PLANET FINDER TELESCOPE
TERTIARY MIRROR
TECHNICAL SPECIFICATION**

TS-5697-2

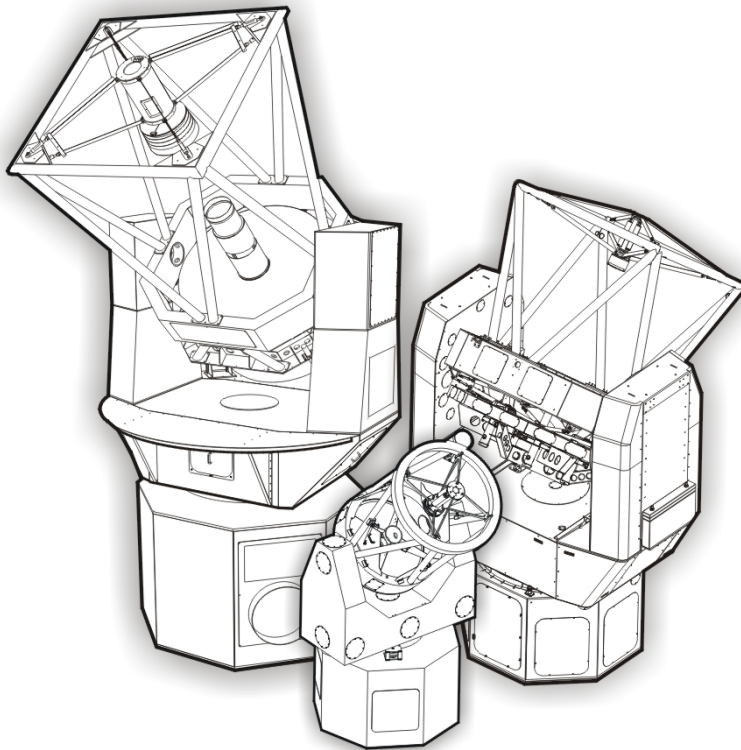

This document and enclosed information is the property of EOS Technologies, Inc. The information contained herein is confidential and cannot be used for commercial or any other purposes. This document may not be copied nor disclosed without prior written approval of EOS Technologies, Inc.

DOCUMENT CONTROL**Issue: 2**

Prepared:	Paul Sherman	Date: 9/29/04
Checked:	Kevin Harris	Date: 9/29/04
Approved:	Bruce Cook	Date: 9/29/04
Configured:	Edith Hatch	Date: 9/29/04

Issue	Date	Description	Prep	Chk	Appr
1	Sept. 7,2004	Initial release	PTS		
2	Sept. 29, 2004	Updated size specification	PTS	KH	BC

This document and enclosed information remains the property of EOS Technologies, Inc. Information herein may not be copied nor disclosed without written consent of EOST Management.

© EOS Technologies, Inc., Tucson, AZ, USA

TABLE OF CONTENTS

1.	INTRODUCTION	4
1.1	SCOPE	4
1.2	CONFIGURATION STATUS	4
2.	GENERAL REQUIREMENTS	4
3.	MECHANICAL CONFIGURATION	4
3.1	MATERIAL	4
3.2	SHAPE	4
3.3	MECHANICAL DIAMETER	4
3.4	CENTER THICKNESS	4
3.5	EDGE CHAMFER	5
3.6	CENTER MARKING	5
4.	OPTICAL SURFACE	5
4.1	GENERAL	5
4.2	CLEAR APERTURE	5
4.3	SUBSURFACE DAMAGE	5
4.4	MICROROUGHNESS	5
4.5	WAVEFRONT QUALITY	5
5.	TESTING	6
5.1	TEST REQUIREMENT	6
5.2	SPATIAL SAMPLING	6
5.3	DATA POINTS	6
5.4	TEST ACCURACY	6
5.5	NO SMOOTHING	6
6.	DOCUMENTATION	6
6.1	INSPECTION MAP	6
6.2	TESTING AND INSPECTION REPORTS	7

AUTOMATED PLANET FINDER TELESCOPE TERTIARY MIRROR TECHNICAL SPECIFICATION

1. INTRODUCTION

1.1 SCOPE

This document describes the technical specifications for the Tertiary mirror for the Automated Planet Finder Telescope.

1.2 CONFIGURATION STATUS

This document has been configured as TS-5697 and is a designated controlled document under the EOST Quality System.

2. GENERAL REQUIREMENTS

To acquire, grind, polish, figure and test a Tertiary mirror with a clear aperture of 390mm x 275mm (elliptical) to a Flat shape.

3. MECHANICAL CONFIGURATION

3.1 MATERIAL

The mirror material shall be a mirror grade zero expansion glass or glass ceramic (eg ULE, Zerodur, Astrosital or equivalent) with coefficient of thermal expansion (CTE) $< 0 \pm 3 \times 10^{-8} \text{ }^\circ\text{C}^{-1}$.

3.2 SHAPE

The substrate shall be plano-plano. Edges and chamfers shall be generated to 24 micron grit (P800).

3.3 MECHANICAL DIAMETER

The edge shall be ground to a mechanical diameter of 408.32mm x 294.58mm ± 1 mm concentric with the optical axis within 0.5 mm. See mechanical drawing COM-5906.

3.4 CENTER THICKNESS

The central thickness shall be nominally 58.0mm ± 0.5 mm

3.5 EDGE CHAMFER

The front edge of the finished mirror shall have a 45° bevel with a hypotenuse length of 2.0mm ±0.5 mm. Bevel shall be provided by optical fabricator.

3.6 CENTER MARKING

Vendor shall scribe a mark within 0.5 mm of the mechanical center of the mirror. The mechanical and optical centers shall be aligned to better than 0.5 mm.

4. OPTICAL SURFACE

4.1 GENERAL

The finished optic will be used as the Tertiary mirror in an astronomical telescope. The front face of the mirror shall have the optical clear aperture given below. The surface outside of the clear aperture shall be polished to the same cosmetic quality as the clear aperture, but is not required to meet the wavefront specification. The mirror shall be finished to an optical flat .

4.2 CLEAR APERTURE

All the requirements of this specification shall be met and tested over the following annular area. See mechanical drawing COM-5672.

Clear Aperture Outside Diameter: > 390.00mm x 275.00mm

4.3 SUBSURFACE DAMAGE

The optician shall grind and polish the optical surface through a series of successively smaller grits as necessary to remove the subsurface damage from each previous grind.

4.4 MICROROUGHNESS

The mirror surface shall be figured and polished to 20 Å rms or better surface roughness. The scratch/dig of the surface shall be 60-40 S/D or better. The contractor shall define and perform a test to verify that the surface roughness specification has been met.

4.5 WAVEFRONT QUALITY

The wavefront error (WFE) from the final polished surface, excluding scratches/digs, shall have a maximum rms WFE of 16 nm. The maximum peak-to-valley (PV) WFE, based on a sampling described below, shall not exceed 63 nm.

5. TESTING

5.1 TEST REQUIREMENT

The clear aperture of the mirror shall be interferometrically tested at a wavelength of 633 nm using a nulling test to verify that the area of the clear optical aperture surface figure meets the peak-to-valley and rms requirements. The vendor will prepare a report describing the test method.

Alternatively, vendor may propose an alternative test method (eg test plate) that meets EOST's requirement to verify that the finished mirror meets the specifications. The vendor will prepare a report describing the test method and results for approval by EOST.

5.2 SPATIAL SAMPLING

The test shall be have a minimum spatial sampling resolution of 1 mm on the optic measured perpendicular to the optical axis.

5.3 DATA POINTS

Test data may be filtered to remove noise. Any filtering will not reject more than 2% of the full aperture data. The remaining 98% of the data points contained within the clear aperture must be within the peak-to-valley specification.

5.4 TEST ACCURACY

The test accuracy for full aperture interferometry, including the effects of null optics, vibration and optical shop seeing must be included in the maximum rms WFE requirement.

5.5 NO SMOOTHING

No post spatial smoothing of the surface map is to be allowed other than that provided by averaging of multiple measurements.

6. DOCUMENTATION

6.1 INSPECTION MAP

The front surface of the mirror shall be examined for surface defects. An inspection map shall be made if live fractures are found. The fractured area will be ground out with a small hand held grinder to eliminate any chance of the fracture growing. EOST is to be notified of the live fractures before any repair is made.

6.2 TESTING AND INSPECTION REPORTS

Reports of testing and inspections accomplished per this specification shall be delivered at the time of delivery of the mirror to EOST. This includes, at minimum, a full aperture interferogram.