

DRAWING NO. **ASY-11731** REVISION **REL-03**

PROJECT CODE: **LICK-51**

MATERIAL: BY COMPONENT
 CONDITION: BY COMPONENT
 FINISH: BY COMPONENT
 FINISH COLOR: BY COMPONENT
 APPROXIMATE MASS: 3155717.57 gm
 REFERENCE DOCUMENTS: ASY-6782 (2.4 METER PRIMARY MIRROR ASSY)

REV.	DATE	DESCRIPTION	CHK'D	APP'V'D	ZONE
1	4/5/2007	INITIAL RELEASE	KG	KG	
2	3/3/2008	REVISE PER ECO-1090	LRG	KG	
3	6/5/2008	REVISED PER ECO-1142	<i>LRG</i>	<i>KG</i>	

Controlled Document
Confirm revision before using

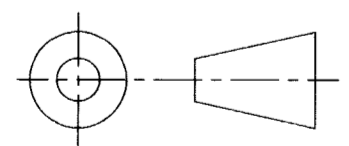
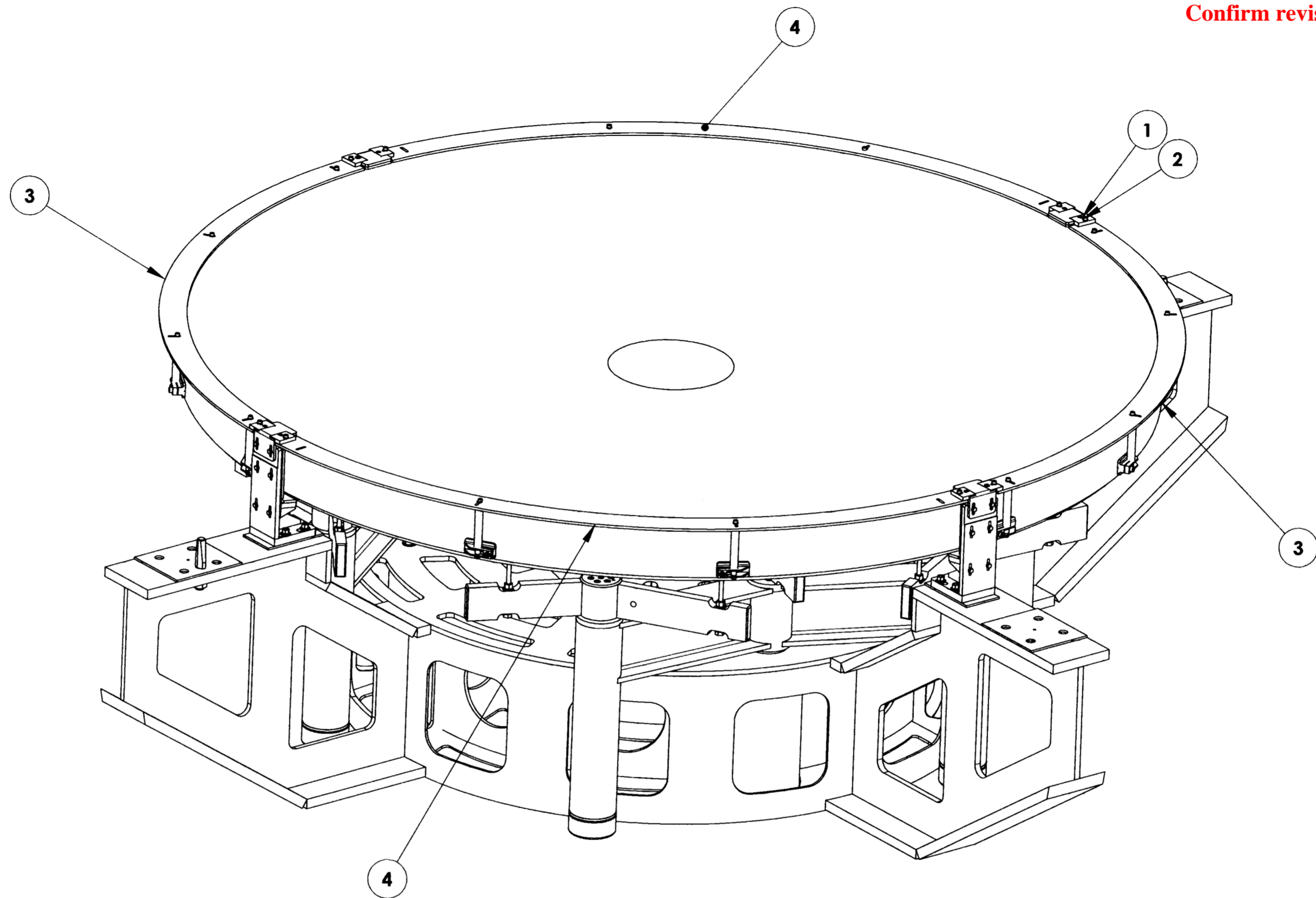

DO NOT SCALE DRAWING

ITEM NO.	Default/ QTY.	PART NUMBER	DESCRIPTION	Material	Weight
4	2	ASY-11723	RADIAL PUCK BONDING ASSY, MIRRORED	PER COMPONENT	6406.03
3	2	ASY-11712	RADIAL PUCK BONDING ASSEMBLY	PER COMPONENT	6528.26
2	8	40355	WASHER, FLAT, M6	FASTENAL, ZINC PLATED ALLOY STEEL	0.004
1	8	0135913	SHCS, M6-1.0 X 10	FASTENAL, ZINC PLATED ALLOY STEEL	8.55

COPYRIGHT THIS DOCUMENT & ENCLOSED PROPRIETARY INFORMATION REMAINS THE PROPERTY OF EOS TECHNOLOGIES, INC. THE INTELLECTUAL PROPERTY AND INFORMATION HEREIN MAY NOT BE COPIED NOR DISCLOSED WITHOUT WRITTEN CONSENT OF EOS TECHNOLOGIES, INC. MANAGEMENT	INTERPRET DIMENSIONS PER ASME Y14.5M-1994 UNLESS OTHERWISE SPECIFIED: DIMENSIONS ARE IN MILLIMETERS TOLERANCES: X.X = ±0.25MM X.XX = ±0.10MM ANGLES = ±0.5° ROUNDS AND FILLETS ARE R3.0 BREAK ALL SHARP EDGES 0.25MM X 0.25MM	WELDS ARE: MAX SIZE FILLET OR FULL PENETRATION GROOVE AS APPROPRIATE. ALL WELDS ARE CONTINUOUS NEAREST NOMINAL STOCK SIZE MAY BE SUBSTITUTED. INDICATED MACHINED SURFACES \checkmark 3.2	DESIGN	J. LOPEZ	DATE	3/20/07	EOS TECHNOLOGIES, INC. 3160 E. TRANSCON WAY, SUITE 180, TUCSON, AZ 85706 PH: (520) 624-6399			
			DRAWN	J. LOPEZ	DATE	3/20/07				
CHECKED	K. GONZALES	DATE	4/5/07							
APPROVED	K. GONZALES	DATE	4/5/07							
REVIEWED	J. LOPEZ	DATE	3/20/07							
TITLE RADIAL PUCK BONDING ASSY, TOP							DRAWING NO. ASY-11731	STATUS Released	REVISION REL-03	SHEET SIZE A2
							SHEET 1 OF 1	SCALE 1:10		