

DRAWING NO. **ASY-12202** REVISION **REL-01**

PROJECT CODE: **LICK-51**

MATERIAL: PER COMPONENT  
 CONDITION: PER COMPONENT  
 SURFACE FINISH: PER COMPONENT  
 FINISH COLOR: PER COMPONENT  
 APPROXIMATE MASS: 560782.70 gm  
 REFERENCE DOCUMENTS: N/A

REV.	DATE	DESCRIPTION	CHKD	APPVD	ZONE
1	4/15/07	INITIAL RELEASE	m	(signature)	

**Controlled Document**  
 Confirm revision before using

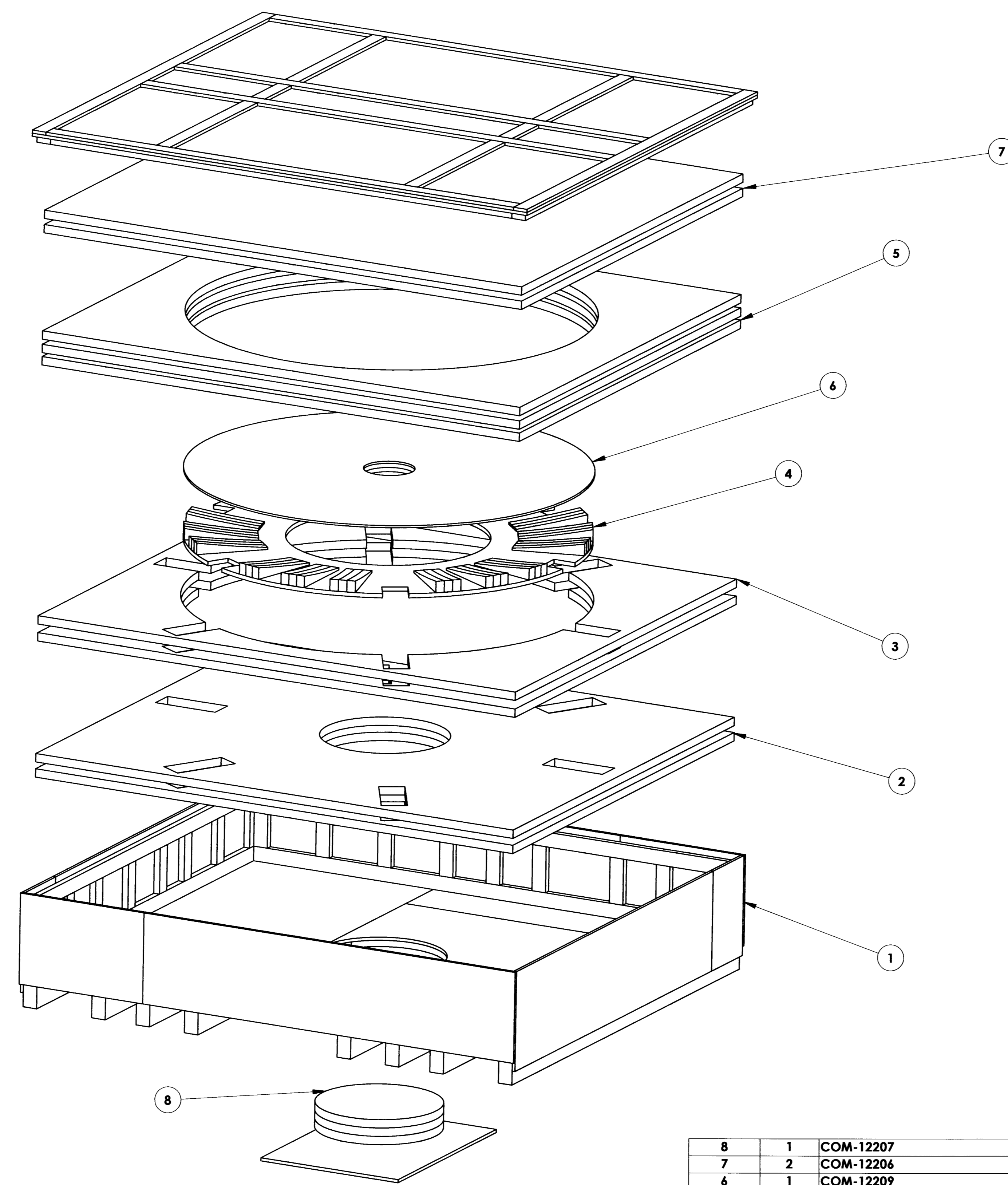

ITEM NO.	QTY.	PART NUMBER	DESCRIPTION	Material	Weight
8	1	COM-12207	CENTER HOLE FILLER INSERT	polyplank	2150.48
7	2	COM-12206	LAYER 8 POLYPLANK INSERT	polyplank	13988.52
6	1	COM-12209	MIRRIR COVER INSERT	polyplank	6989.24
5	3	COM-12205	LAYER 5 POLYPLANK INSERT	polyplank	6634.48
4	1	COM-12208	MIRROR SUPPORT LAYER	POLYPLANK	4057.31
3	2	COM-12204	LAYER 3 POLYPLANK INSERT	polyplank	6196.71
2	2	COM-12203	LAYER 1 POLYPLANK INSERT	polyplank	12661.97
1	1	ASY-12194	M1 MIRROR CRATE, 2400MM MIRROR	PER COMPONENT	461987.81

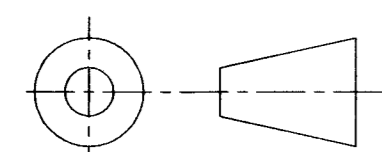

DO NOT SCALE DRAWING

**COPYRIGHT**

THIS DOCUMENT & ENCLOSED PROPRIETARY INFORMATION REMAINS THE PROPERTY OF EOS TECHNOLOGIES, INC. THE INTELLECTUAL PROPERTY AND INFORMATION HEREIN MAY NOT BE COPIED NOR DISCLOSED WITHOUT WRITTEN CONSENT OF EOS TECHNOLOGIES, INC. MANAGEMENT

INTERPRET DIMENSIONS PER ASME Y14.5M-1994 UNLESS OTHERWISE SPECIFIED:

DIMENSIONS ARE IN MILLIMETERS  
 X.X = ±0.25MM  
 X.XX = ±0.10MM  
 ANGLES = ±0.5°

ROUNDS AND FILLETS ARE R3.0  
 BREAK ALL SHARP EDGES 0.25MM X 0.25MM

WELDS ARE: MAX SIZE FILLET OR FULL PENETRATION GROOVE WELD AS APPROPRIATE.

ALL WELDS ARE CONTINUOUS

NEAREST NOMINAL STOCK SIZE MAY BE SUBSTITUTED UPON APPROVAL.

INDICATED MACHINED SURFACES  3.2

DESIGN	DATE
L. GREGERSEN	3/22/07
DRAWN	DATE
L. GREGERSEN	3/23/07
CHECKED	DATE
(signature)	4/15/07
APPROVED	DATE
(signature)	4/15/07
REVIEWED	DATE
(signature)	4/15/07

<b>EOS TECHNOLOGIES, INC.</b>	
3160 E. TRANSCON WAY, SUITE 180, TUCSON, AZ 85706 PH: (520) 624-6399	
<b>TITLE</b>	
<b>M1 CRATE WITH PACKING, 2400 MM MIRROR</b>	
<b>DRAWING NO.</b>	<b>STATUS</b>
<b>ASY-12202</b>	Released
<b>REVISION</b>	<b>SHEET SIZE</b>
<b>REL-01</b>	<b>A1</b>
<b>SHEET</b> 1 OF 2	<b>SCALE</b> 1:33.3