

DRAWING NO. **ASY-12362** REVISION **REL-01**

PROJECT CODE: **LICK-51**

MATERIAL: PER COMPONENT
 CONDITION: PER COMPONENT
 FINISH: PER COMPONENT
 FINISH COLOR: PER COMPONENT
 APPROXIMATE MASS: 9084.29 gm
 REFERENCE DOCUMENTS: N/A

REV.	DATE	DESCRIPTION	CHK'D	APPVD	ZONE
1	6/20/07	INITIAL RELEASE	lh	lh	

Controlled Document
Confirm revision before using

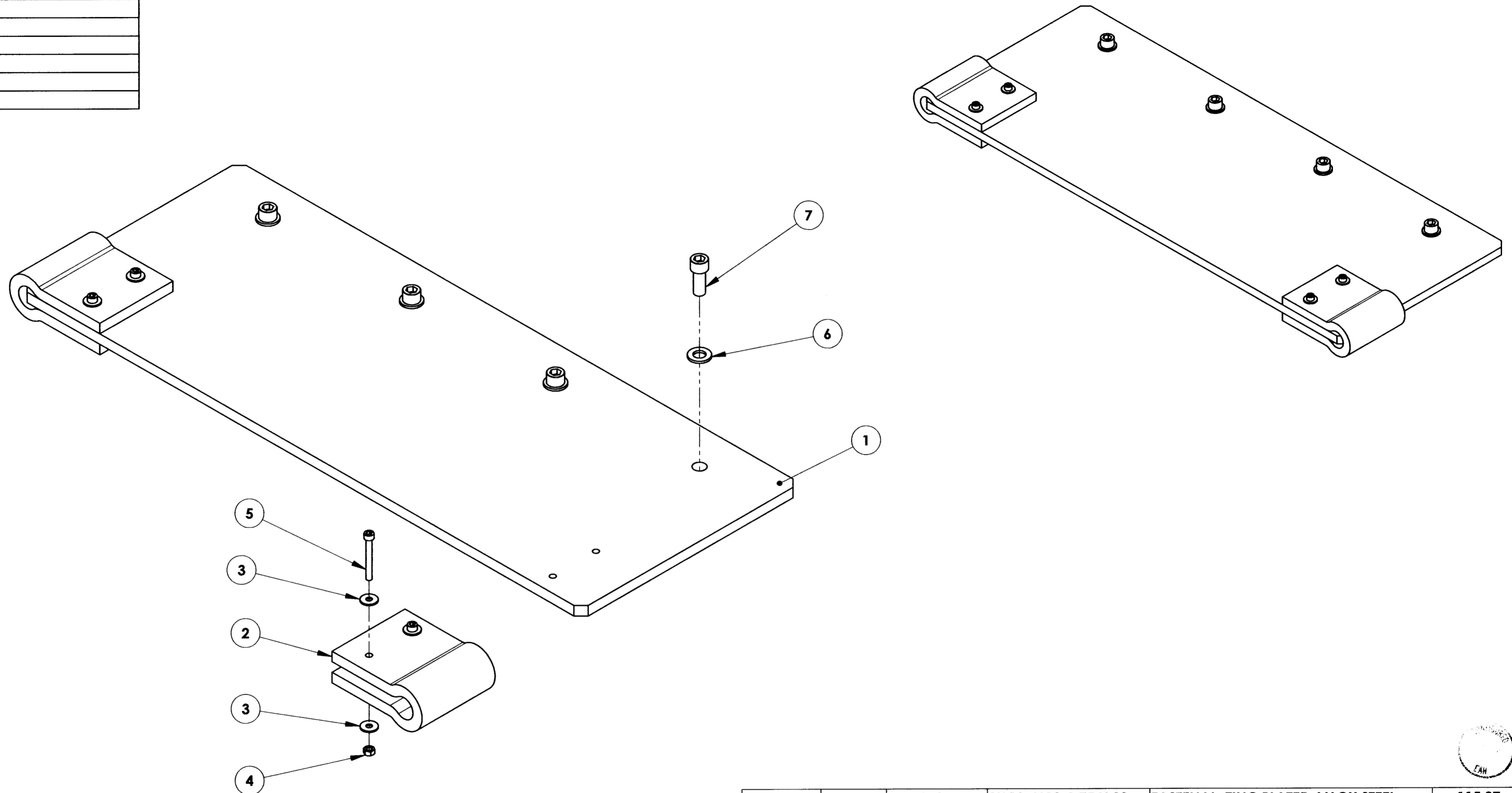

ITEM NO.	QTY.	PART NUMBER	DESCRIPTION	Material	Weight
7	4	0135968	SHCS, M12-1.75 X 30	FASTENAL, ZINC PLATED ALLOY STEEL	115.07
6	4	1140359	WASHER, FLAT, M12	FASTENAL, ZINC PLATED ALLOY STEEL	0.017
5	4	0135925	SHCS, M6-1.0 X 50	FASTENAL, ZINC PLATED ALLOY STEEL	22.68
4	4	1140305	NUT, HEX, M6-1.0	FASTENAL, ZINC PLATED ALLOY STEEL	2.675
3	8	38403	WASHER, FENDER, M6	FASTENAL, ZINC PLATED ALLOY STEEL	0.759
2	2	COM-12361	RUBBER BUMPER	Rubber, MCM 8981K417	336.84
1	1	COM-12360	EL HARD STOP PLATE	6061 Alloy, 12" x 1/2" THK PLATE	8115.87

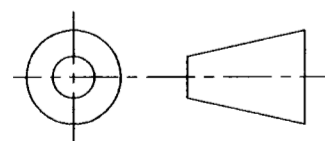

DO NOT SCALE DRAWING

COPYRIGHT THIS DOCUMENT & ENCLOSED PROPRIETARY INFORMATION REMAINS THE PROPERTY OF EOS TECHNOLOGIES, INC. THE INTELLECTUAL PROPERTY AND INFORMATION HEREIN MAY NOT BE COPIED NOR DISCLOSED WITHOUT WRITTEN CONSENT OF EOS TECHNOLOGIES, INC. MANAGEMENT	INTERPRET DIMENSIONS PER ASME Y14.5M-1994 UNLESS OTHERWISE SPECIFIED: DIMENSIONS ARE IN MILLIMETERS TOLERANCES: X.X = ±0.25MM X.XX = ±0.10MM ANGLES = ±0.5° ROUNDS AND FILLETS ARE R3.0 BREAK ALL SHARP EDGES 0.25MM X 0.25MM	WELDS ARE: MAX SIZE FILLET OR FULL PENETRATION GROOVE AS APPROPRIATE. ALL WELDS ARE CONTINUOUS NEAREST NOMINAL STOCK SIZE MAY BE SUBSTITUTED. INDICATED MACHINED SURFACES	DESIGN C. PENTLAND DATE 5-JUN-07 DRAWN C. PENTLAND DATE 5-JUN-07 CHECKED [Signature] DATE [Signature] APPROVED [Signature] DATE [Signature] REVIEWED [Signature] DATE 20 JUN-07	EOS TECHNOLOGIES, INC. 3160 E. TRANSCON WAY, SUITE 180, TUCSON, AZ 85706 PH: (520) 624-6399 EL HARD STOP ASSY		
	DRAWING NO. ASY-12362		STATUS Released	REVISION REL-01	SHEET SIZE A2	
	SHEET 1 OF 1		SCALE 1:3			