

DRAWING NO. ASY-13477	REVISION REL-01
PROJECT CODE: LICK-51	
MATERIAL: PER COMPONENT	
CONDITION: PER COMPONENT	
FINISH: PER COMPONENT	
FINISH COLOR: PER COMPONENT	
APPROXIMATE MASS: 12538.55 gm	
REFERENCE DOCUMENTS: N/A	

REV.	DATE	DESCRIPTION	CHK'D	APPV'D	ZONE
1	12/17/08	INITIAL RELEASE			

Controlled Document
Confirm revision before using

- NOTES:**
- BOND ITEM 3 TO ITEM 2, AND ITEM 5 TO ITEM 4 USING HYSOL EA 9330.3 QT SYSTEM ADHESIVE PER MANUFACTURERS DIRECTIONS.
 - SET BOND GAP USING 0.4 TO 0.5 DIA. NYLON FILAMENT

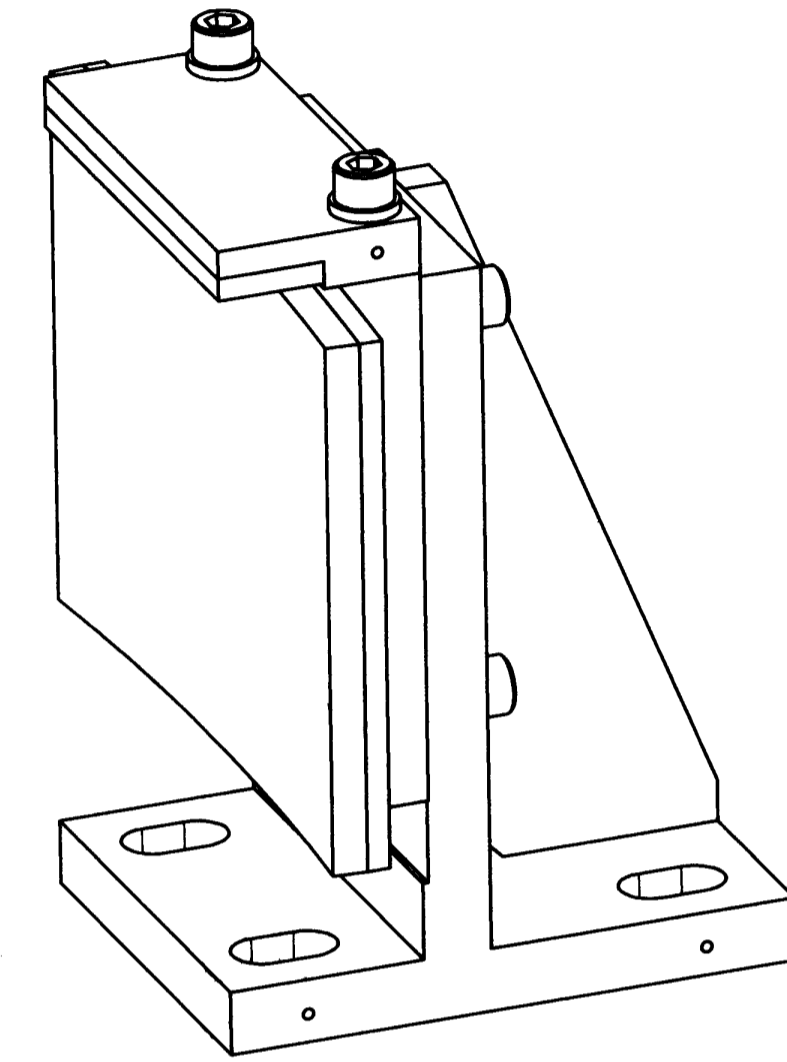
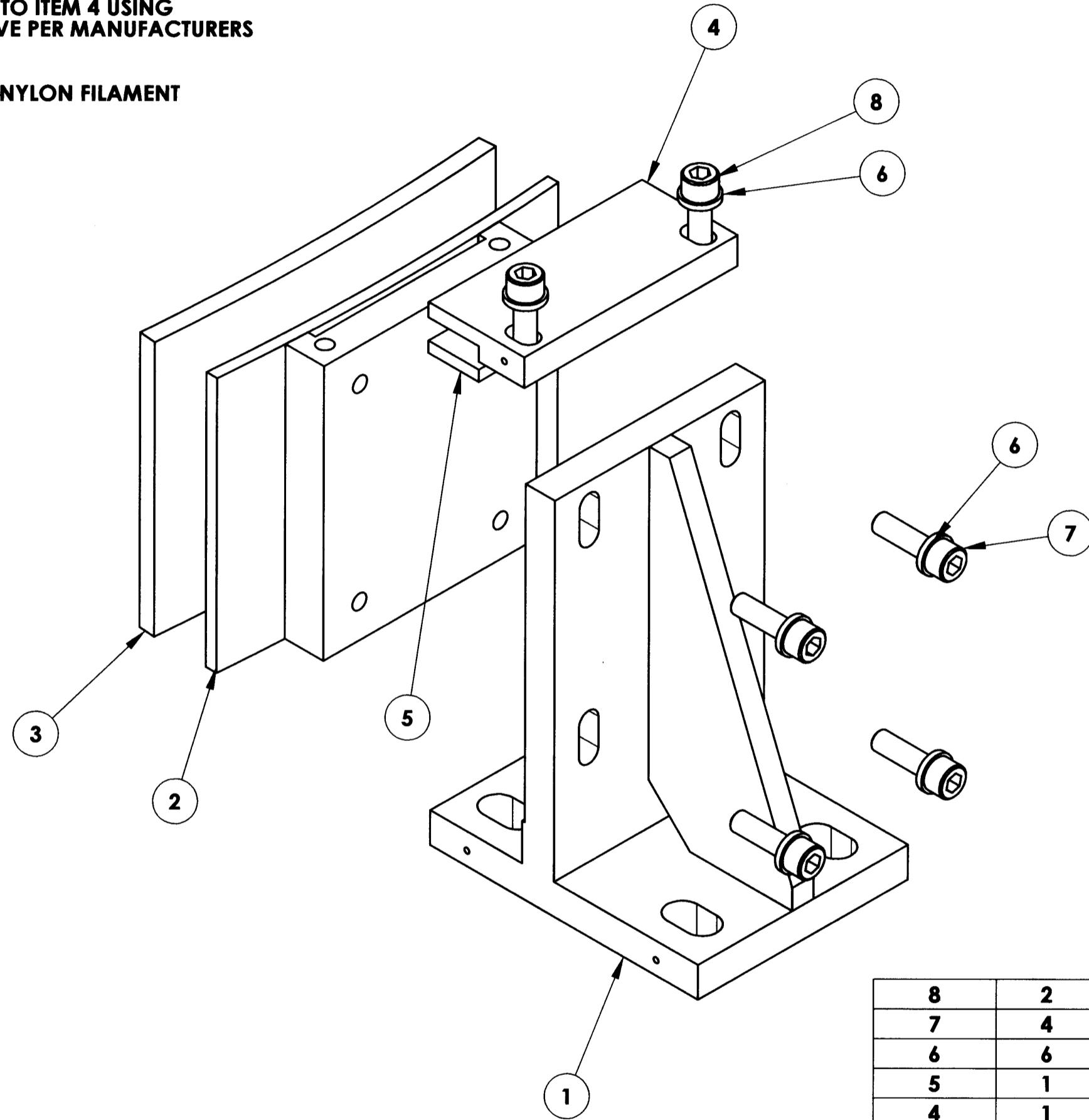

ITEM NO.	QTY.	PART NUMBER	DESCRIPTION	Material	Weight
8	2	CPP-13526	SCREW, M10-1.5 X 30 SHCS	18-8 STAINLESS STEEL,	30.02
7	4	CPP-13527	SCREW, M10-1.5 X 35 SHCS	18-8 STAINLESS STEEL,	33.04
6	6	CPP-13530	WASHER, FLAT M-10	18-8 STAINLESS STEEL,	4.55
5	1	COM-13482	MIRROR RETANER PAD	VITON 1/4" THICK 75A DUROMETER	56.37
4	1	COM-13481	MIRROR RETAINER BAR	304 STAINLESS STEEL	615.41
3	1	COM-13479	MIRROR SUPPORT PAD	VITON 3/8" THICK 75A DUROMETER	685.37
2	1	COM-13478	SUPPORT PAD WELDMENT	304 STAINLESS STEEL	4282.08
1	1	COM-13480	MIRROR RETAINER BRACKET	304 STAINLESS STEEL	6679.82

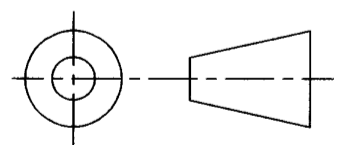

DO NOT SCALE DRAWING

<p>COPYRIGHT</p> <p>THIS DOCUMENT & ENCLOSED PROPRIETARY INFORMATION REMAINS THE PROPERTY OF EOS TECHNOLOGIES, INC. THE INTELLECTUAL PROPERTY AND INFORMATION HEREIN MAY NOT BE COPIED NOR DISCLOSED WITHOUT WRITTEN CONSENT OF EOS TECHNOLOGIES, INC. MANAGEMENT</p>	<p>INTERPRET DIMENSIONS PER ASME Y14.5M-1994</p> <p>UNLESS OTHERWISE SPECIFIED:</p> <p>DIMENSIONS ARE IN MILLIMETERS</p> <p>TOLERANCES:</p> <p>X.X = ±0.25MM</p> <p>X.XX = ±0.10MM</p> <p>ANGLES = ±0.5°</p> <p>ROUNDS AND FILLETS ARE R3.0</p> <p>BREAK ALL SHARP EDGES</p> <p>0.25MM X 0.25MM</p>	<p>WELDS ARE: MAX SIZE FILLET OR FULL PENETRATION GROOVE AS APPROPRIATE.</p> <p>ALL WELDS ARE CONTINUOUS</p> <p>NEAREST NOMINAL STOCK SIZE MAY BE SUBSTITUTED.</p> <p>INDICATED MACHINED SURFACES</p> <p>3.2 ✓</p>	DESIGN L. GREGERSEN	DATE 11/17/08	<p>EOS TECHNOLOGIES, INC.</p> <p>3160 E. TRANSCON WAY, SUITE 180, TUCSON, AZ 85706 PH: (520) 624-6399</p>
			DRAWN L. GREGERSEN	DATE 12/11/08	
			CHECKED	DATE 12/17/08	DRAWING NO. ASY-13477
			APPROVED	DATE 12/17/08	STATUS Released
			REVIEWED - DESIGN	DATE 12/17/08	REVISION REL-01
			REVIEWED - ASSEMBLY	DATE 12/17/08	SHEET 1 OF 1
					SCALE 1:5
					CONFIG. # FRM-12377-1
					SHEET SIZE A2