

DRAWING NO. ASY-13483	REVISION REL-01
PROJECT CODE: LICK-51	
MATERIAL: PER COMPONENT	
CONDITION: PER COMPONENT	
FINISH: PER COMPONENT	
FINISH COLOR: PER COMPONENT	
APPROXIMATE MASS: 4330.91 gm	
REFERENCE DOCUMENTS: N/A	

REV.	DATE	DESCRIPTION	CHK'D	APP'VD	ZONE
1	11/17/08	INITIAL RELEASE	<i>W</i>	<i>M</i>	

Controlled Document
Confirm revision before using

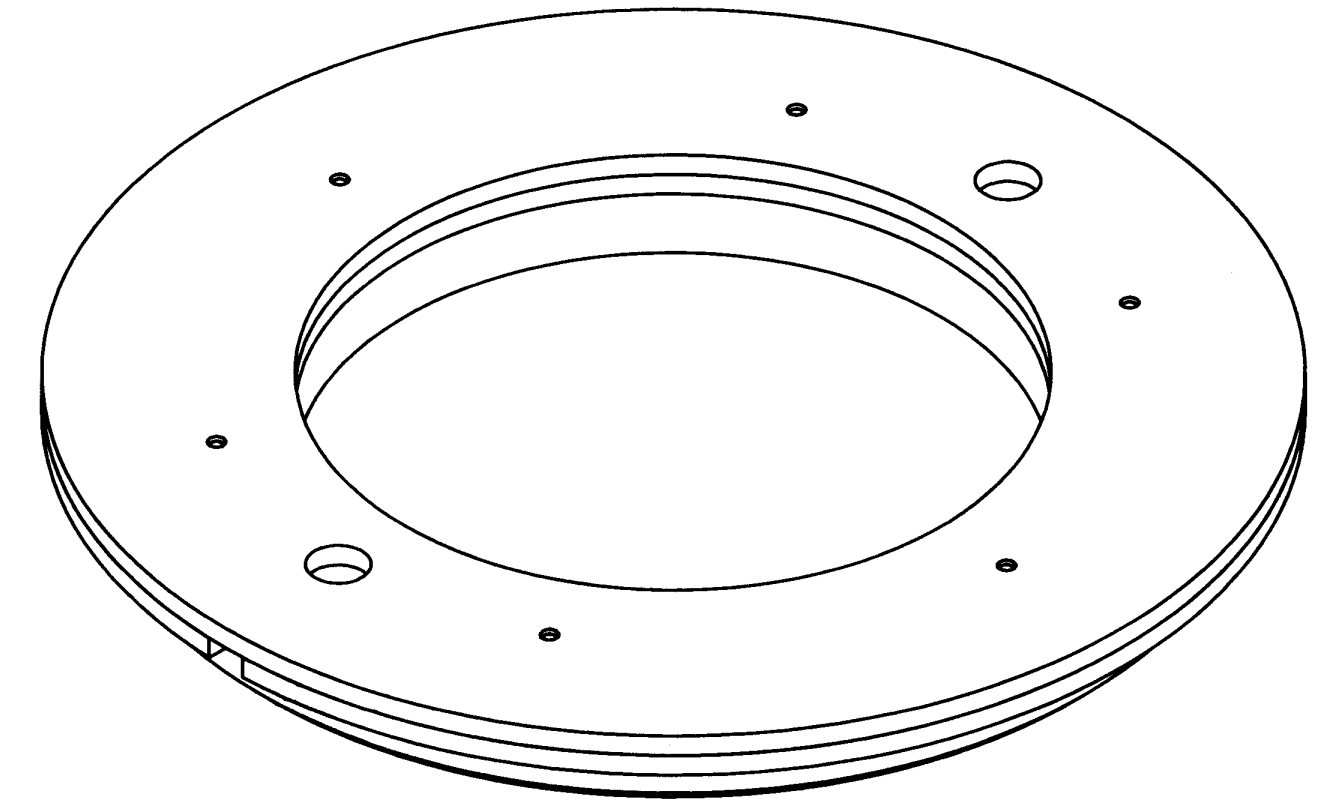
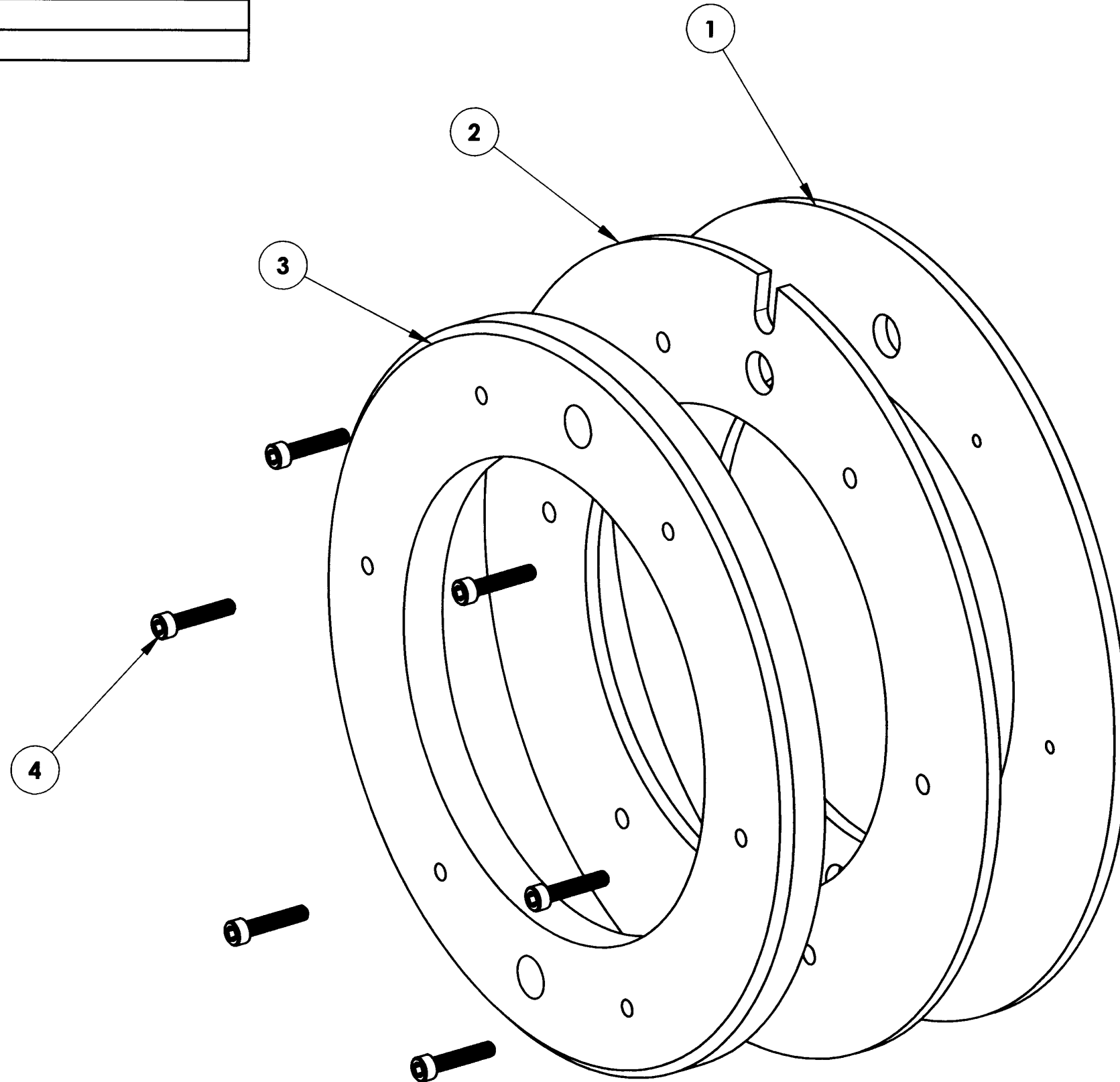

ITEM NO.	QTY.	PART NUMBER	DESCRIPTION	Material	Weight
4	6	CPP-13524	SCREW, M6-1.0 X 30 SHCS	18-8 STAINLESS STEEL	8.16
3	1	COM-13486	RETAINER CENTERING PLUG	POLYETHYLENE 3/4" THICK HDPE	751.65
2	1	COM-13485	CENTER RETAINER VITON PAD	VITON 1/4" THICK 75A DUROMETER	811.68
1	1	COM-13484	CENTER RETAINER PLATE	304 STAINLESS STEEL	2718.62

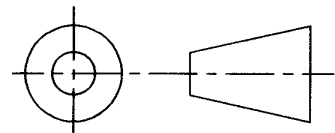

DO NOT SCALE DRAWING

<p style="text-align: center;">COPYRIGHT</p> <p style="font-size: 8px;">THIS DOCUMENT & ENCLOSED PROPRIETARY INFORMATION REMAINS THE PROPERTY OF EOS TECHNOLOGIES, INC. THE INTELLECTUAL PROPERTY AND INFORMATION HEREIN MAY NOT BE COPIED NOR DISCLOSED WITHOUT WRITTEN CONSENT OF EOS TECHNOLOGIES, INC. MANAGEMENT</p>	<p>INTERPRET DIMENSIONS PER ASME Y14.5M-1994</p> <p>UNLESS OTHERWISE SPECIFIED:</p> <p>DIMENSIONS ARE IN MILLIMETERS</p> <p>TOLERANCES:</p> <p>X.X = ±0.25MM</p> <p>X.XX = ±0.10MM</p> <p>ANGLES = ±0.5°</p> <p>ROUNDS AND FILLETS ARE R3.0</p> <p>BREAK ALL SHARP EDGES</p> <p>0.25MM X 0.25MM</p>	<p>WELDS ARE: MAX SIZE FILLET OR FULL PENETRATION GROOVE AS APPROPRIATE.</p> <p>ALL WELDS ARE CONTINUOUS</p> <p>NEAREST NOMINAL STOCK SIZE MAY BE SUBSTITUTED.</p> <p>INDICATED MACHINED SURFACES ✓</p>	DESIGN	L. GREGERSEN	DATE	11/17/08	<p>EOS TECHNOLOGIES, INC. 3160 E. TRANSCON WAY, SUITE 180, TUCSON, AZ 85706 PH: (520) 624-6399</p>			
			DRAWN	L. GREGERSEN	DATE	12/10/08				
			CHECKED	<i>[Signature]</i>	DATE	12/17/08	<p>CENTER RETAINER PLATE ASY.</p>			
			APPROVED	<i>[Signature]</i>	DATE	12/17/08				
			REVIEWED - DESIGN	<i>[Signature]</i>	DATE	12/17/08	<p>DRAWING NO. ASY-13483</p>			
			REVIEWED - ASSEMBLY	<i>[Signature]</i>	DATE	12/17/08				
					STATUS	Released	REVISION	REL-01	SHEET SIZE	A2
					SHEET 1 OF 1		SCALE 1:5			
					CONFIG. # FRM-12377-1					