

REV.	DATE	DESCRIPTION	CHKD	APPVD	ZONE
1	11-10-04	INITIAL RELEASE	KCLW	JAY	

DRAWING NO.	REVISION
<b>ASY-5131</b>	<b>REL-01</b>
PROJECT CODE:	LICK-51
REQUIRED PER TELESCOPE:	3 MIDDLE LOADSPREADERS PER TELESCOPE
MATERIAL:	AISI 304
CONDITION:	N/A
SURFACE FINISH:	N/A
FINISH COLOR:	N/A
APPROXIMATE MASS:	20470 gm

NOTES:  
 1) AN ALIGNMENT FIXTURE MUST BE UTILIZED TO PROPERLY ALIGN THE LOADSPREADER ARMS WITH THE HUB.  
 USE Ø6.00 mm DOWEL PINS TO LOCATE THE ARMS AS SHOWN.  
 2. BEAD BLAST ENTIRE WELDMENT TO ELIMINATE DISCOLORATION AND GIVE A UNIFORM APPEARANCE.

Controlled Document  
 Confirm revision before using

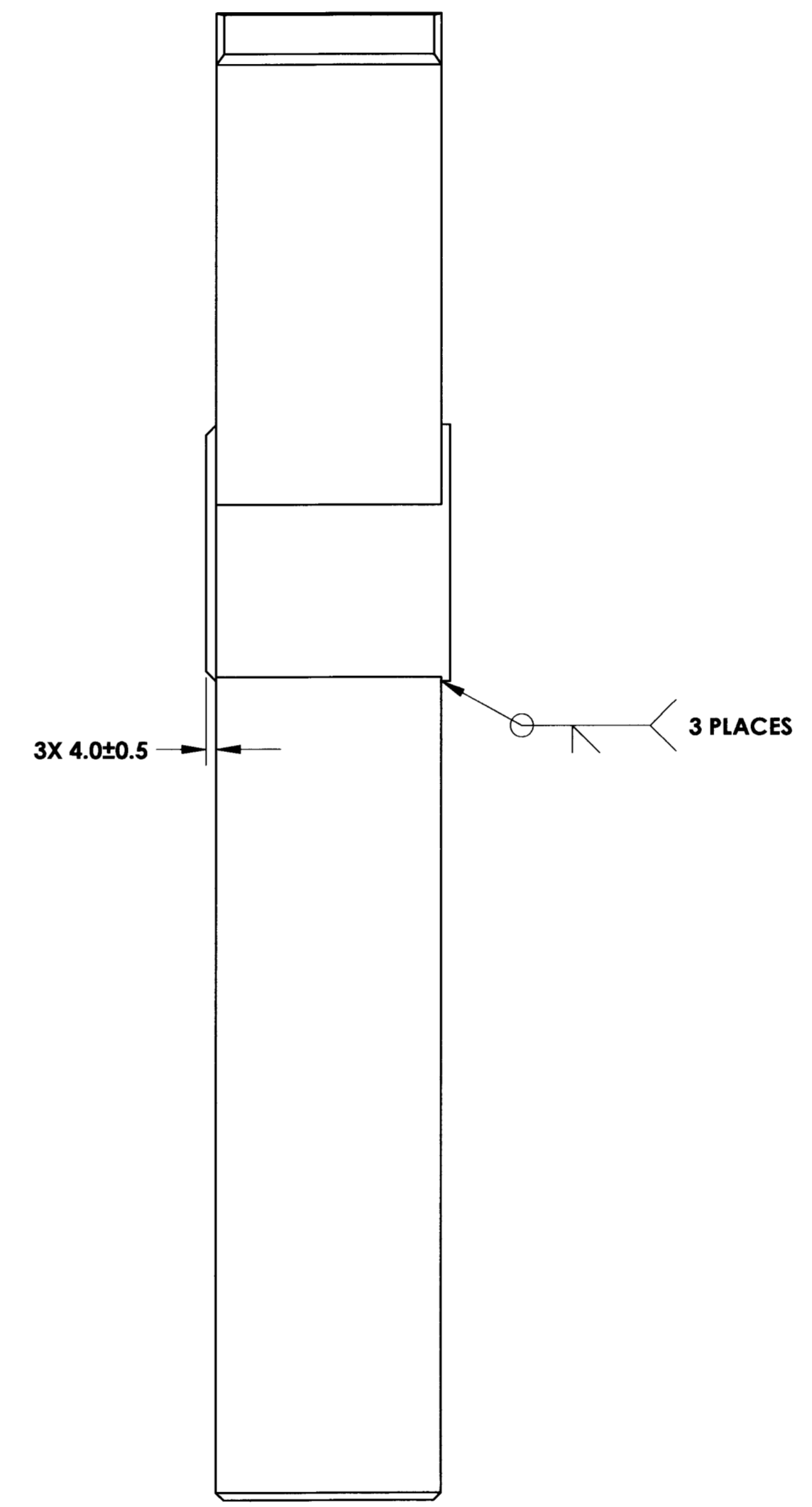
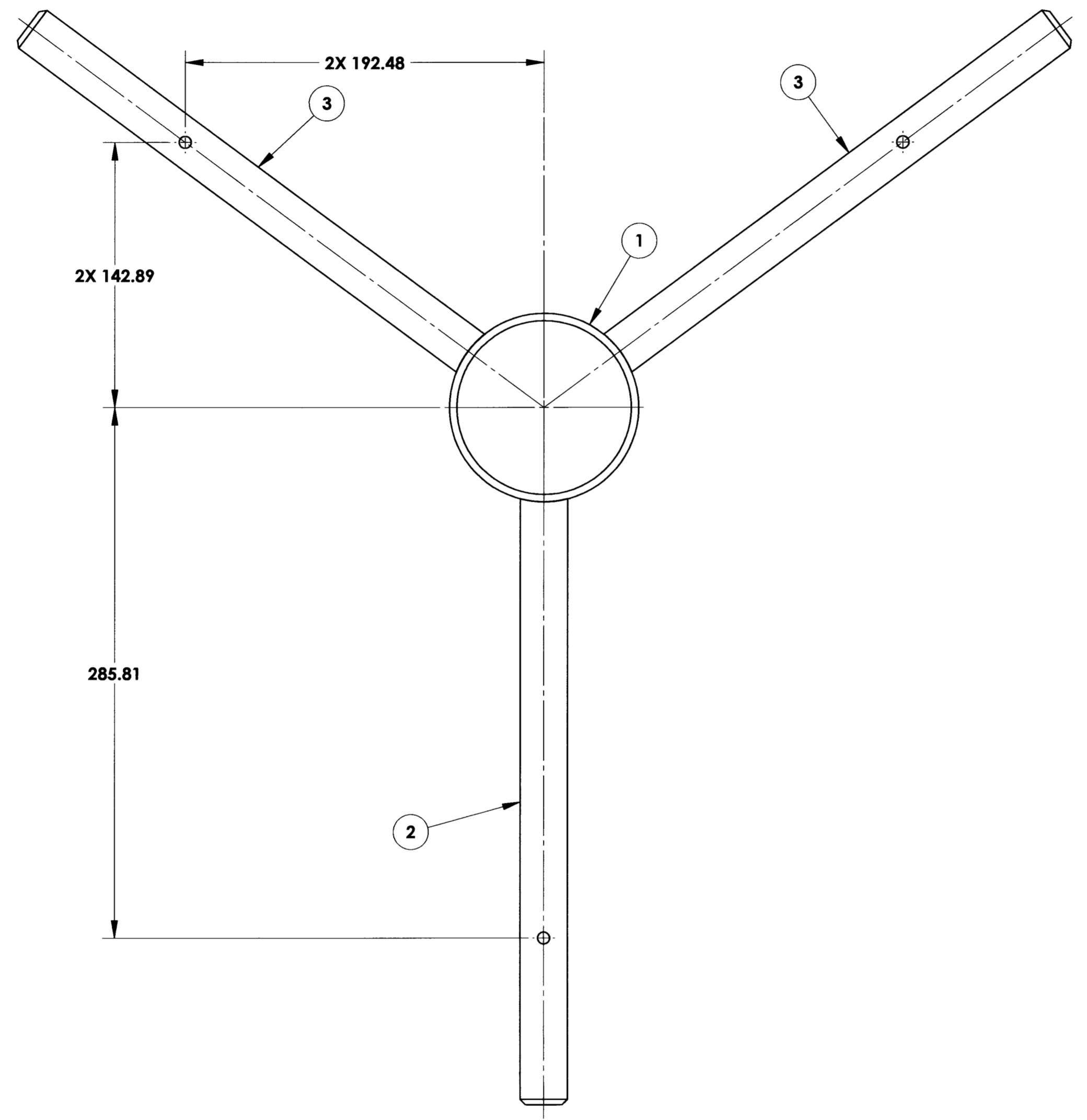
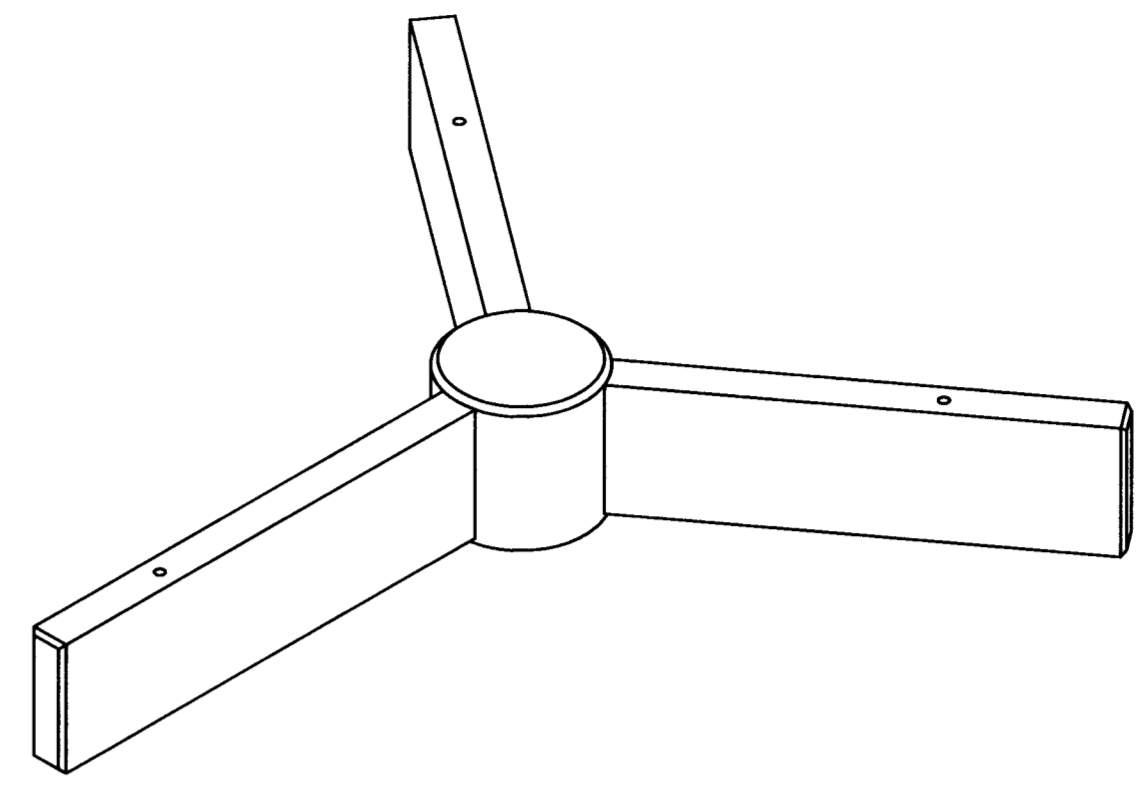

3	2	COM-5136	MIDDLE LOADSPREADER ARM II	AISI 304, 1" x 3-1/2" BAR STOCK	5310
2	1	COM-5135	MIDDLE LOADSPREADER ARM I	AISI 304 1" x 3-1/2" BAR STOCK	5860
1	1	COM-5134	LOADSPREADER HUB	AISI 304, 4" ROD STOCK	3981
ITEM NO.	QTY.	PART NUMBER	DESCRIPTION	Material	Weight

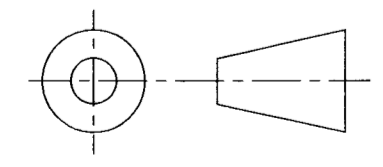

**COPYRIGHT**  
 THIS DOCUMENT & ENCLOSED PROPRIETARY INFORMATION REMAINS THE PROPERTY OF EOS TECHNOLOGIES, INC. THE INTELLECTUAL PROPERTY AND INFORMATION HEREIN MAY NOT BE COPIED NOR DISCLOSED WITHOUT WRITTEN CONSENT OF EOS TECHNOLOGIES, INC. MANAGEMENT

UNLESS OTHERWISE SPECIFIED:  
 DIMENSIONS ARE IN MILLIMETERS  
 X.X = ±0.25MM  
 X.XX = ±0.10MM  
 ANGLES = ±0.5°  
 ROUNDS AND FILLETS ARE R3.0  
 BREAK ALL SHARP EDGES 0.25MM X 0.25MM

WELDS ARE: MAX SIZE FILLET OR FULL PENETRATION GROOVE WELD AS APPROPRIATE.  
 ALL WELDS ARE CONTINUOUS  
 NEAREST NOMINAL STOCK SIZE MAY BE SUBSTITUTED UPON APPROVAL.  
 INDICATED MACHINED SURFACES

DESIGN	M. NICKERSON	DATE	11/24/03
DRAWN	J. CATONE	DATE	1/8/04
CHECKED	<i>Pro. Wilson</i>	DATE	11-10-04
APPROVED	<i>J. Catone</i>	DATE	11/10/04

**EOS TECHNOLOGIES, INCORPORATED**  
 925 W. GRANT RD, TUCSON, AZ 85705 PH: (520) 624-6399 www.eostech.com

**MIDDLE LOADSPREADER - WELDMENT**

DRAWING NO. **ASY-5131** STATUS Released REVISION **REL-01** SHEET SIZE **A1**

SCALE 1:2 SHEET 1 OF 1