

DRAWING NO.	REVISION
ASY-5143	REL-01
PROJECT CODE:	LICK-51
REQUIRED PER TELESCOPE:	3 RH OUTER LOADSPREADERS PER TELESCOPE
MATERIAL:	AISI 304
CONDITION:	N/A
SURFACE FINISH:	N/A
FINISH COLOR:	N/A
APPROXIMATE MASS:	19621 gm

NOTES:
 1) AN ALIGNMENT FIXTURE MUST BE UTILIZED TO PROPERLY ALIGN THE LOADSPREADER ARMS WITH THE HUB. USE Ø6 mm DOWEL PINS TO LOCATE THE ARMS AS SHOWN.
 2) BEAD BLAST ENTIRE WELDMENT TO ELIMINATE DISCOLORATION AND GIVE A UNIFORM APPEARANCE.

REV.	DATE	DESCRIPTION	CHKD	APPVD	ZONE
1	11-10-04	INITIAL RELEASE	K. Catone	5/1/04	

Controlled Document
 Confirm revision before using

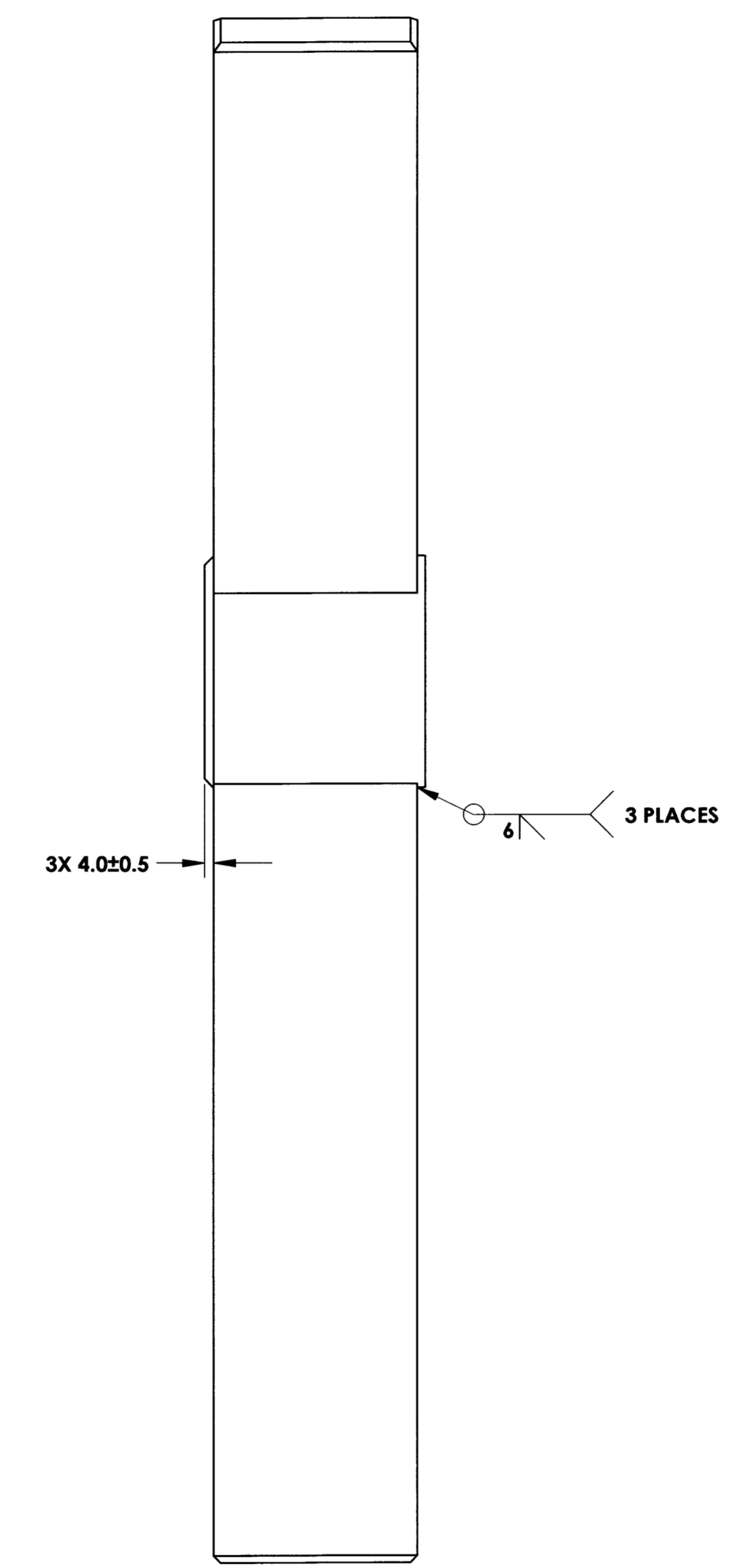
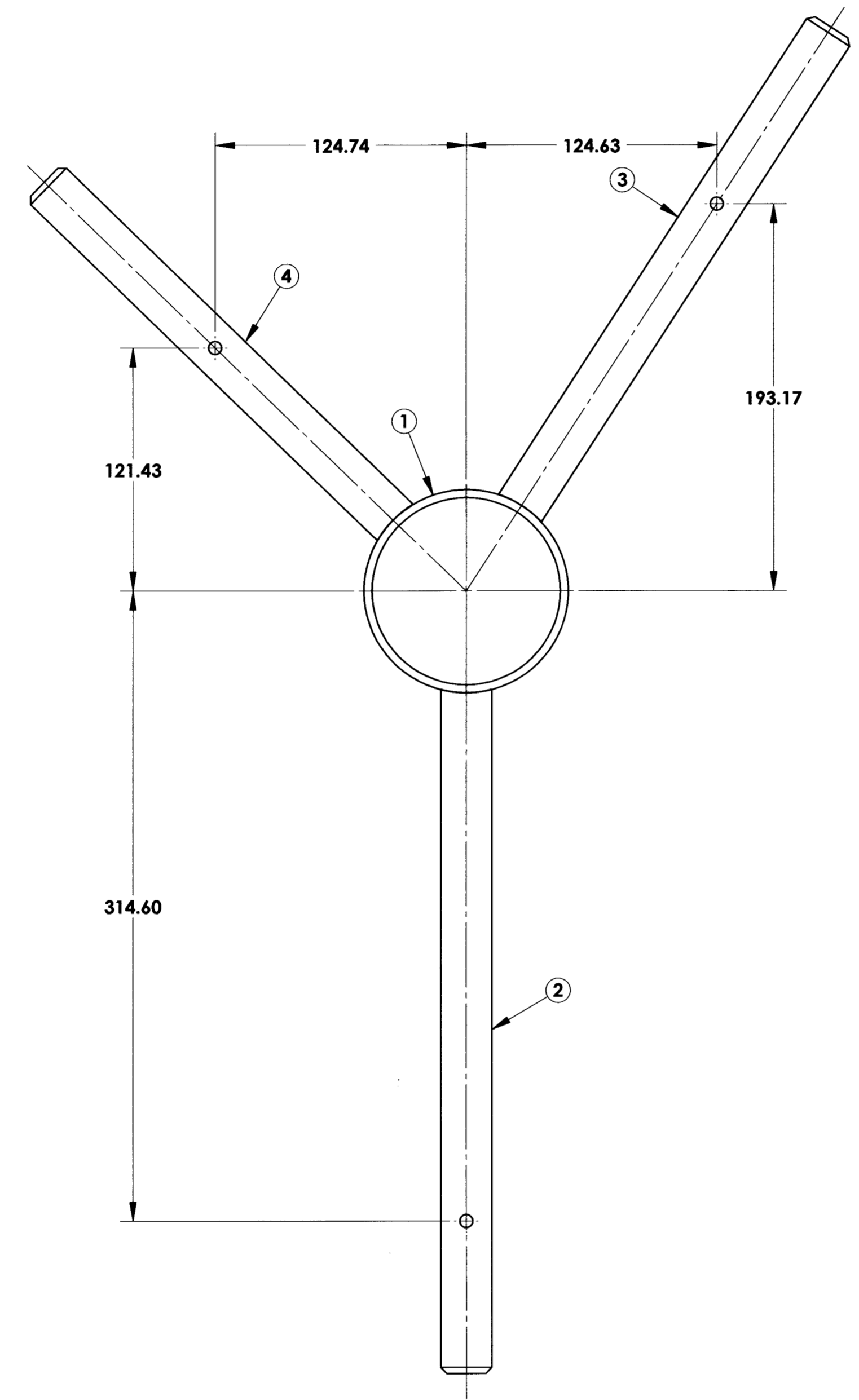
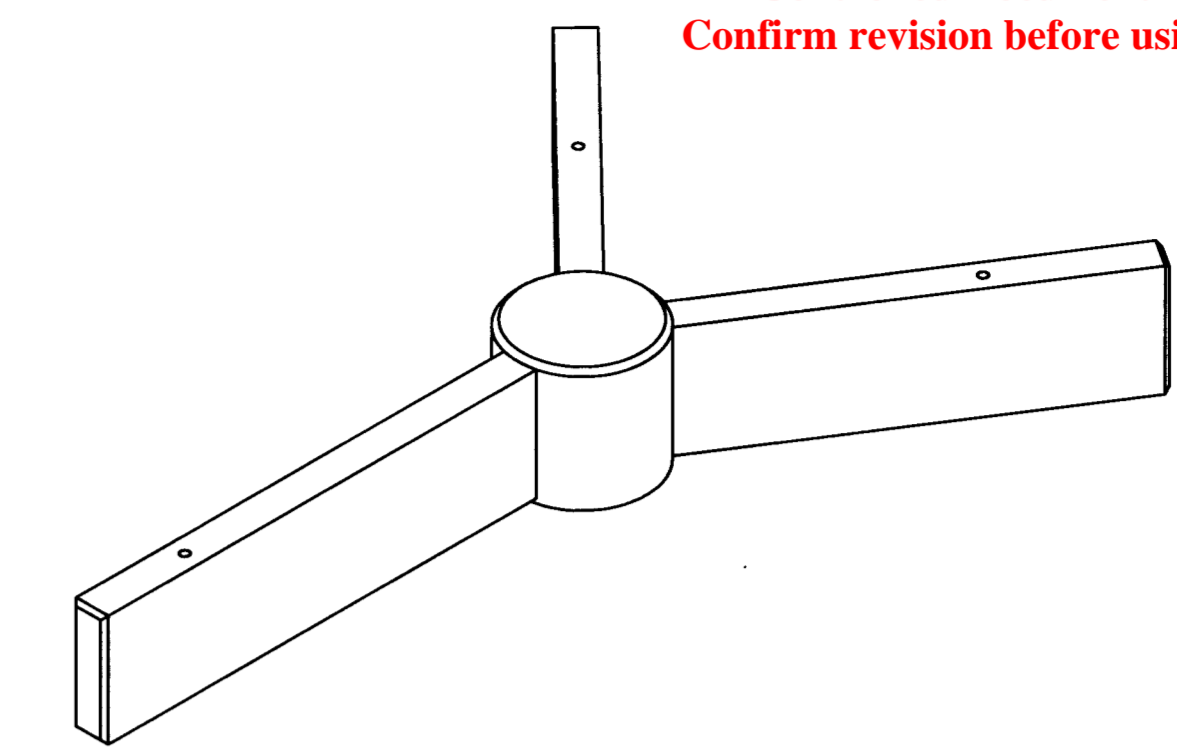

ITEM NO.	QTY.	PART NUMBER	DESCRIPTION	Material	Weight
4	1	COM-5142	OUTER LOADSPREADER ARM III	AISI 304, 1" x 3-1/2" BAR STOCK	4370
3	1	COM-5141	OUTER LOADSPREADER ARM II	AISI 304, 1" x 3-1/2" BAR STOCK	5129
2	1	COM-5140	OUTER LOADSPREADER ARM I	AISI 304 1" x 3-1/2" BAR STOCK	6141
1	1	COM-5134	LOADSPREADER HUB	AISI 304, 4" ROD STOCK	3981

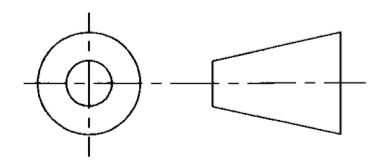

<p align="center">COPYRIGHT</p> <p>THIS DOCUMENT & ENCLOSED PROPRIETARY INFORMATION REMAINS THE PROPERTY OF EOS TECHNOLOGIES, INC. THE INTELLECTUAL PROPERTY AND INFORMATION HEREIN MAY NOT BE COPIED NOR DISCLOSED WITHOUT WRITTEN CONSENT OF EOS TECHNOLOGIES, INC. MANAGEMENT</p>	<p>UNLESS OTHERWISE SPECIFIED:</p> <p>DIMENSIONS ARE IN MILLIMETERS</p> <p>X.X = ±0.25MM</p> <p>X.XX = ±0.10MM</p> <p>ANGLES = ±0.5°</p> <p>ROUNDS AND FILLETS ARE R3.0</p> <p>BREAK ALL SHARP EDGES 0.25MM X 0.25MM</p>	<p>WELDS ARE: MAX SIZE FILLET OR FULL PENETRATION GROOVE WELD AS APPROPRIATE.</p> <p>ALL WELDS ARE CONTINUOUS</p> <p>NEAREST NOMINAL STOCK SIZE MAY BE SUBSTITUTED UPON APPROVAL</p> <p>INDICATED MACHINED SURFACES</p>	<p>DESIGN: M. NICKERSON</p> <p>DRAWN: J. CATONE</p> <p>CHECKED: <i>Per-William</i></p> <p>APPROVED: <i>J. Catone</i></p>	<p>DATE: 11/24/03</p> <p>DATE: 1/21/04</p> <p>DATE: 11-10-04</p> <p>DATE: 4/10/04</p>	<p>EOS EOS TECHNOLOGIES, INCORPORATED</p> <p>925 W. GRANT RD, TUCSON, AZ 85705 PH: (520) 624-6399 www.eostech.com</p> <p>RH OUTER LOADSPREADER - WELDMENT</p>	<p>DRAWING NO. ASY-5143</p> <p>SCALE: 1:2</p>	<p>STATUS: Released</p> <p>SHEET: 1 OF 1</p>	<p>REVISION: REL-01</p> <p>SHEET: 1 OF 1</p>	<p>SHEET SIZE: A1</p>
---	--	---	--	---	---	--	--	---	------------------------------