

DRAWING NO. **ASY-5263** REVISION **REL-01**

COPYRIGHT
 THIS DOCUMENT & ENCLOSED PROPRIETARY INFORMATION REMAINS THE PROPERTY OF EOS TECHNOLOGIES, INC. THE INTELLECTUAL PROPERTY AND INFORMATION HEREIN MAY NOT BE COPIED NOR DISCLOSED WITHOUT WRITTEN CONSENT OF EOS TECHNOLOGIES, INC. MANAGEMENT

REV.	DATE	DESCRIPTION	CHK'D	APP'VD	ZONE
1	11-10-04	INITIAL RELEASE	KLW	<i>JH</i>	

PROJECT CODE: **LICK-51**

REQUIRED PER TELESCOPE: 3 TOTAL PER TELESCOPE

MATERIAL: AISI 304

CONDITION: AS SUPPLIED

SURFACE FINISH: AS SUPPLIED

FINISH COLOR: AS SUPPLIED

APPROXIMATE MASS: 2504 gm

Controlled Document
Confirm revision before using

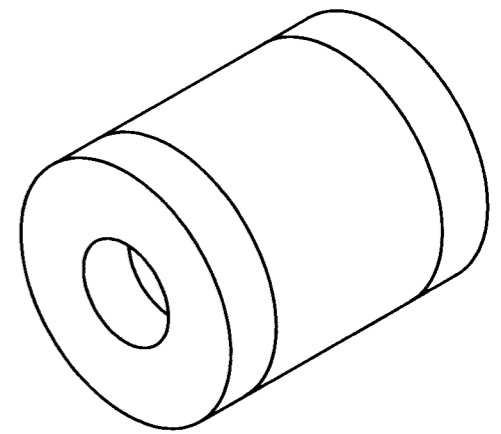

NOTES:
 1) BEAD BLAST ENTIRE WELDMENT TO ELIMINATE DIS-COLORATION AND GIVE A UNIFORM APPEARANCE.

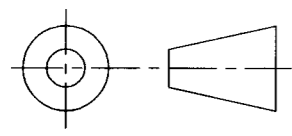
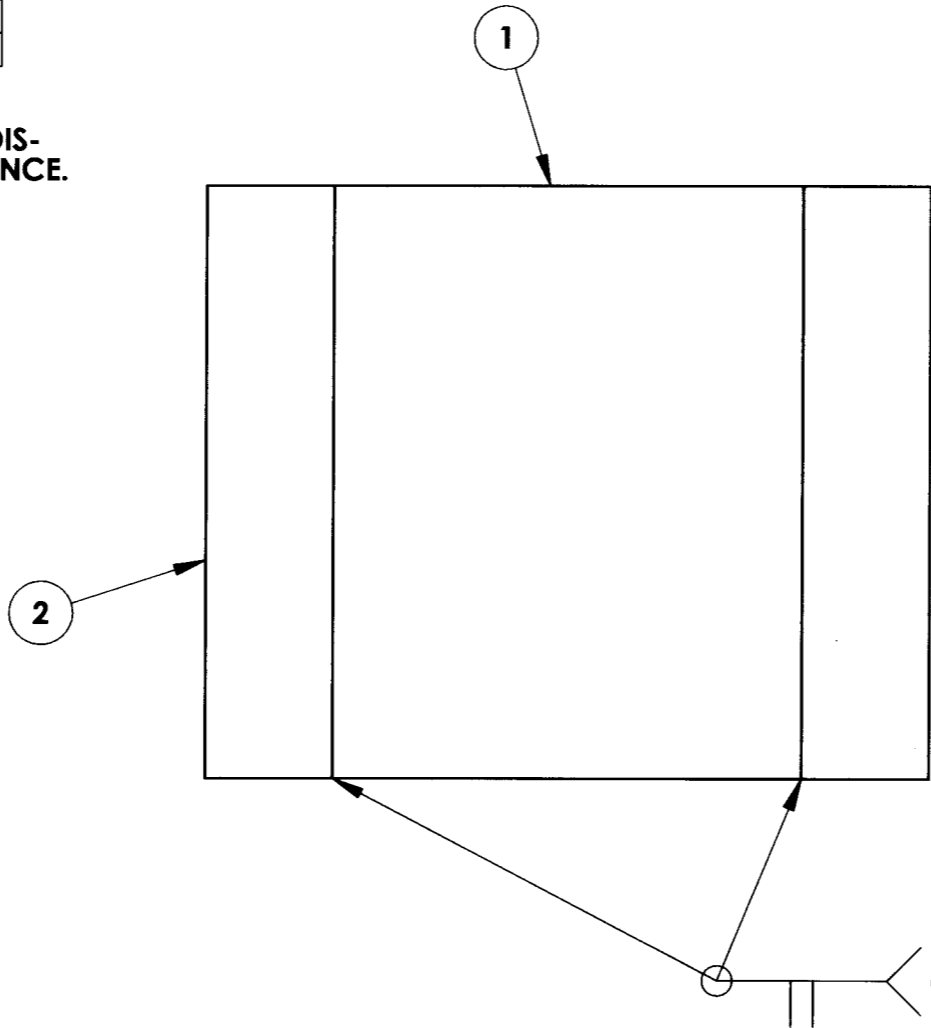

DO NOT SCALE DRAWING

ITEM NO.	QTY.	PART NUMBER	DESCRIPTION	Material	Weight
2	2	COM-5262	LOADSPREADER MOUNTING BRACKET STANDOFF PLATE	AISI 304, 3/4" PLATE	791
1	1	COM-5261	LOADSPREADER MOUNTING BRACKET STANDOFF CYLINDER	AISI 304, Ø3-1/2"x1/4" PIPE	922

UNLESS OTHERWISE SPECIFIED:
 DIMENSIONS ARE IN MILLIMETERS
 X.X = ±0.25
 X.XX = ±0.10
 ANGLES = ±0.5°
 ROUNDS AND FILLETS ARE R3.0
 BREAK ALL SHARP EDGES
 0.25MM X 0.25MM
 INDICATED MACHINED SURFACES

DESIGN	M. NICKERSON	DATE	11/24/03
DRAWN	J. CATONE	DATE	3/2/04
CHECKED	<i>Neil Woodson</i>	DATE	11-10-04
APPROVED	<i>G J Pentland</i>	DATE	11/10/04

EOS		EOS TECHNOLOGIES, INC. 925 WEST GRANT ROAD - TUCSON - ARIZONA - 85705 - (520) 624-6399	
TITLE LOADSPREADER MOUNTING BRACKET STANDOFF - WELDMENT			
DRAWING NO. ASY-5263		STATUS Released	REVISION REL-01
SCALE 1:1		SHEET SIZE A3	