

DRAWING NO. **ASY-5671** REVISION **REL-02**
 PROJECT CODE: **LICK-51**

Controlled Document
 Confirm revision before using

LICK

SCREW THE FEET ON THE MIRROR
 FIXTURE PLATE AS SHOWN AND
 SECURE WITH A VACUUM-SAFE
 THREAD-LOCKING COMPOUND.

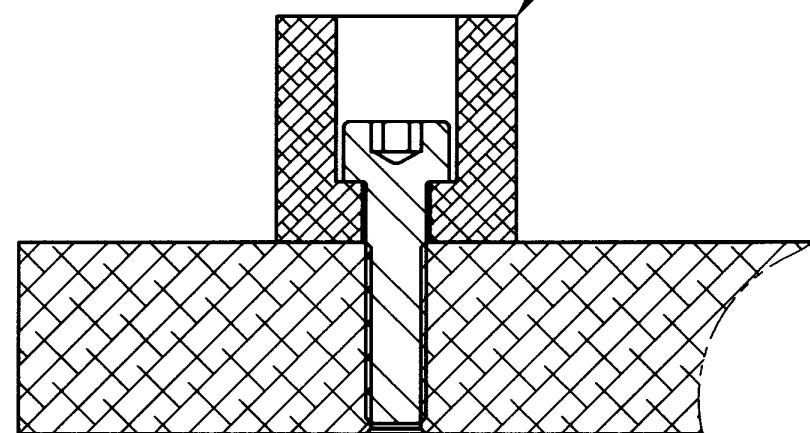

SECTION Y-Y
 (SOME DETAILS NOT
 SHOWN FOR CLARITY)
 SCALE 2 : 1

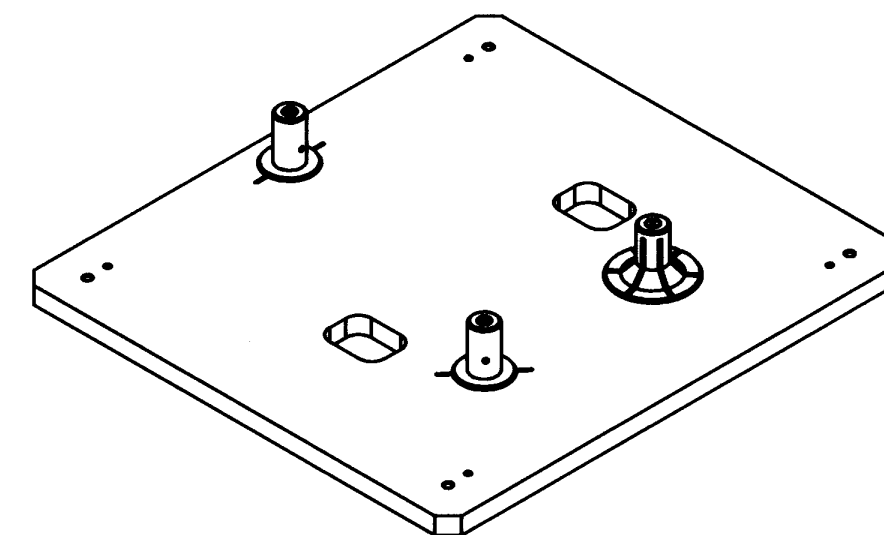
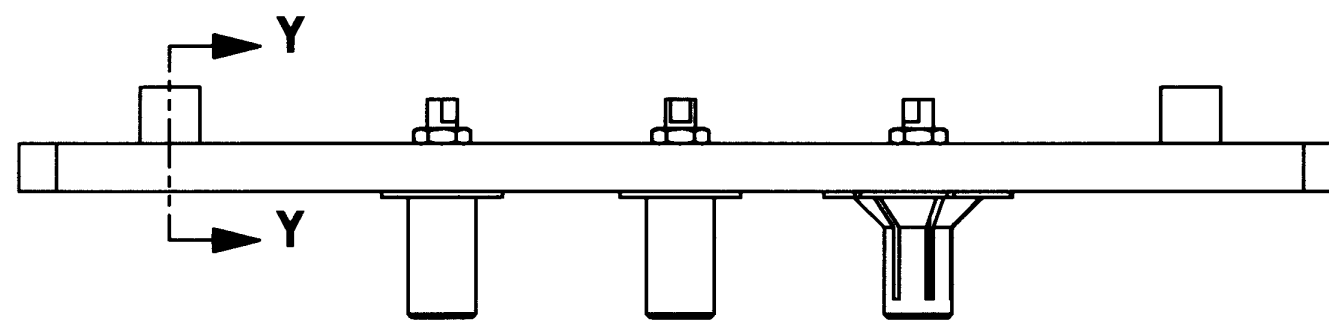

SCREW THE FLEXURE INTO THE MIRROR
 INSERT AND SECURE WITH A VACUUM-
 SAFE THREAD-LOCKING COMPOUND.
 ALLOW TO CURE PRIOR TO MOUNTING
 ON THE FIXTURE PLATE.

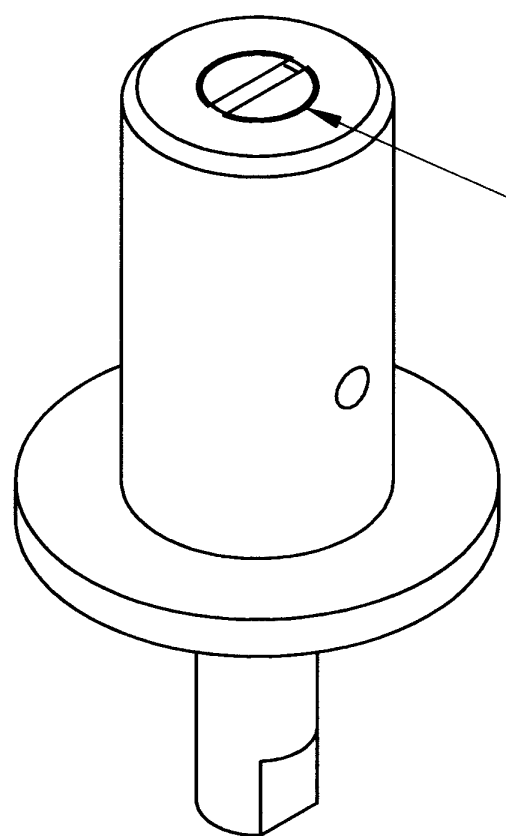

SCALE 2:1

THE SLOT IN THE FLEXURE MUST ALIGN
 WITH THE CORRESPONDING SLOT ON
 THE FIXTURE PLATE AS SHOWN.

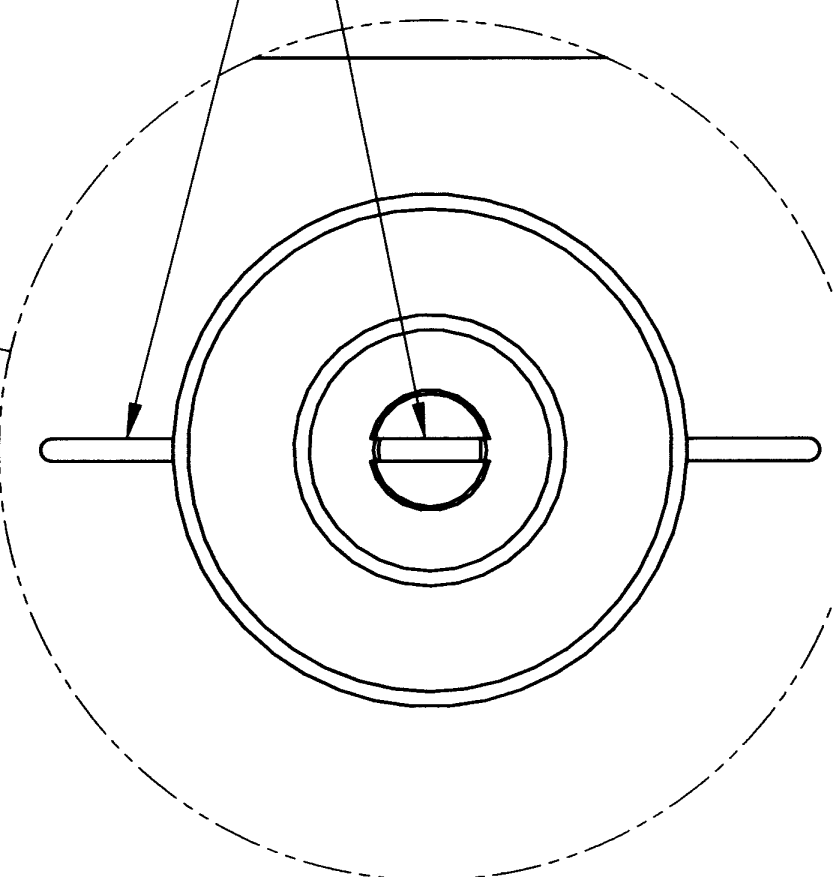
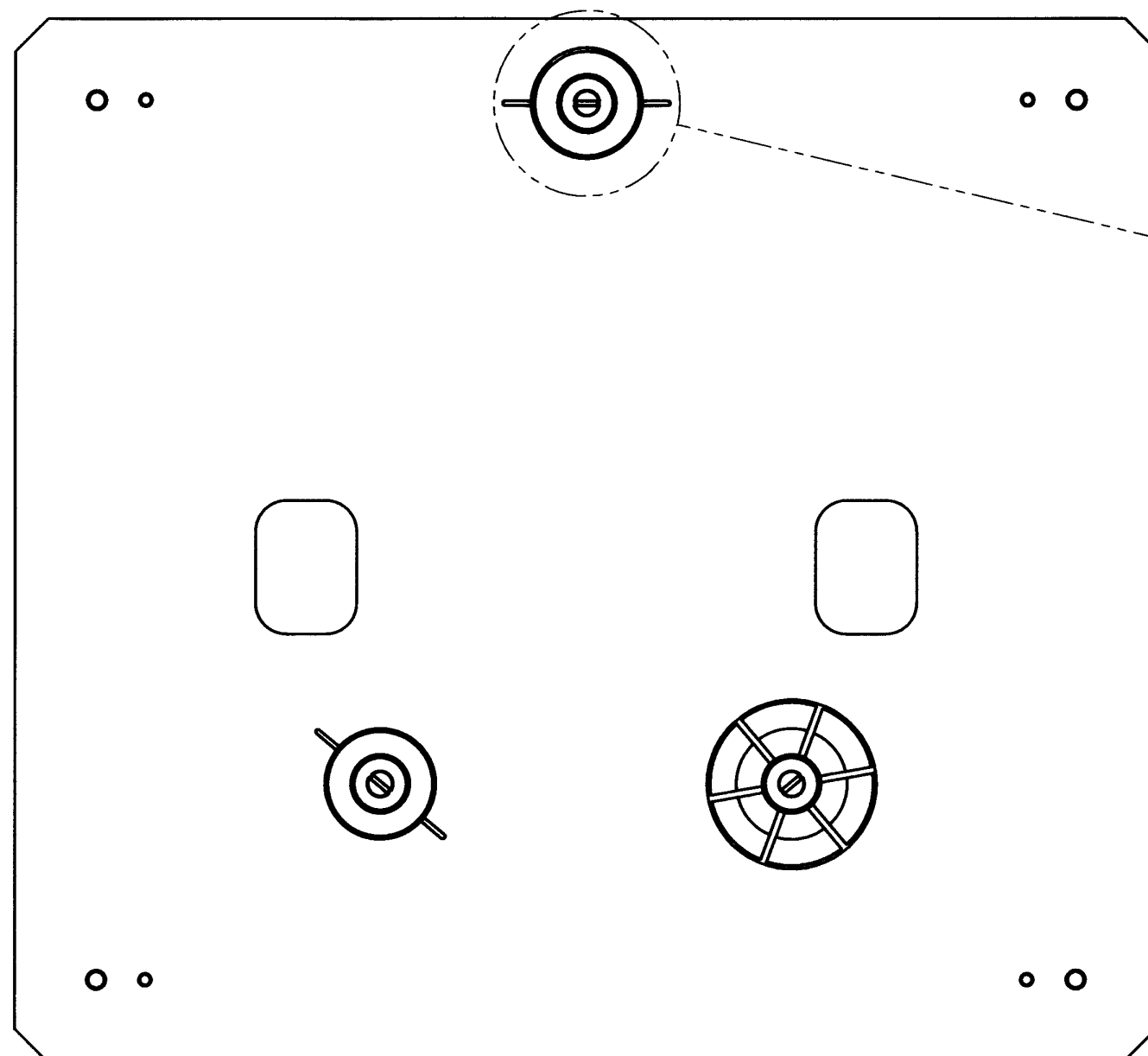

DETAIL B
 SCALE 2 : 1

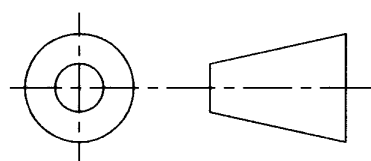

**DO NOT SCALE DRAWING
 DIMENSIONS IN MILLIMETERS**

COPYRIGHT

THIS DOCUMENT & ENCLOSED PROPRIETARY
 INFORMATION REMAINS THE PROPERTY OF EOS
 TECHNOLOGIES, INC. THE INTELLECTUAL PROPERTY
 AND INFORMATION HEREIN MAY NOT BE COPIED NOR
 DISCLOSED WITHOUT WRITTEN CONSENT OF
 EOS TECHNOLOGIES, INC. MANAGEMENT



EOS TECHNOLOGIES, INC.
 3160 E. TRANSCON WAY, SUITE 180, TUCSON, AZ 85706 PH: (520) 624-6399

TITLE: M3 MIRROR ASSEMBLY			
DRAWING NO. ASY-5671	STATUS Released	REVISION REL-02	SHEET SIZE A2
SCALE:1:2		SHEET 2 OF 5	