

DRAWING NO. **ASY-5712** REVISION **REL-02**

PROJECT CODE: **LICK 51**

REQUIRED PER TELESCOPE: 1

MATERIAL: ASTM A-36 STEEL

CONDITION: AS SUPPLIED

SURFACE FINISH: AS SUPPLIED

FINISH COLOR: AS SUPPLIED

APPROXIMATE MASS: 1233385 gm

REFERENCE DOCUMENTS:

REV.	DATE	DESCRIPTION	CHK'D	APP'VD	ZONE
1	2-1-05	INITIAL RELEASE	K. WASMER	G. PENTLAND	
2	9-16-05	REVISED PER ECO-0431			

Controlled Document
Confirm revision before using

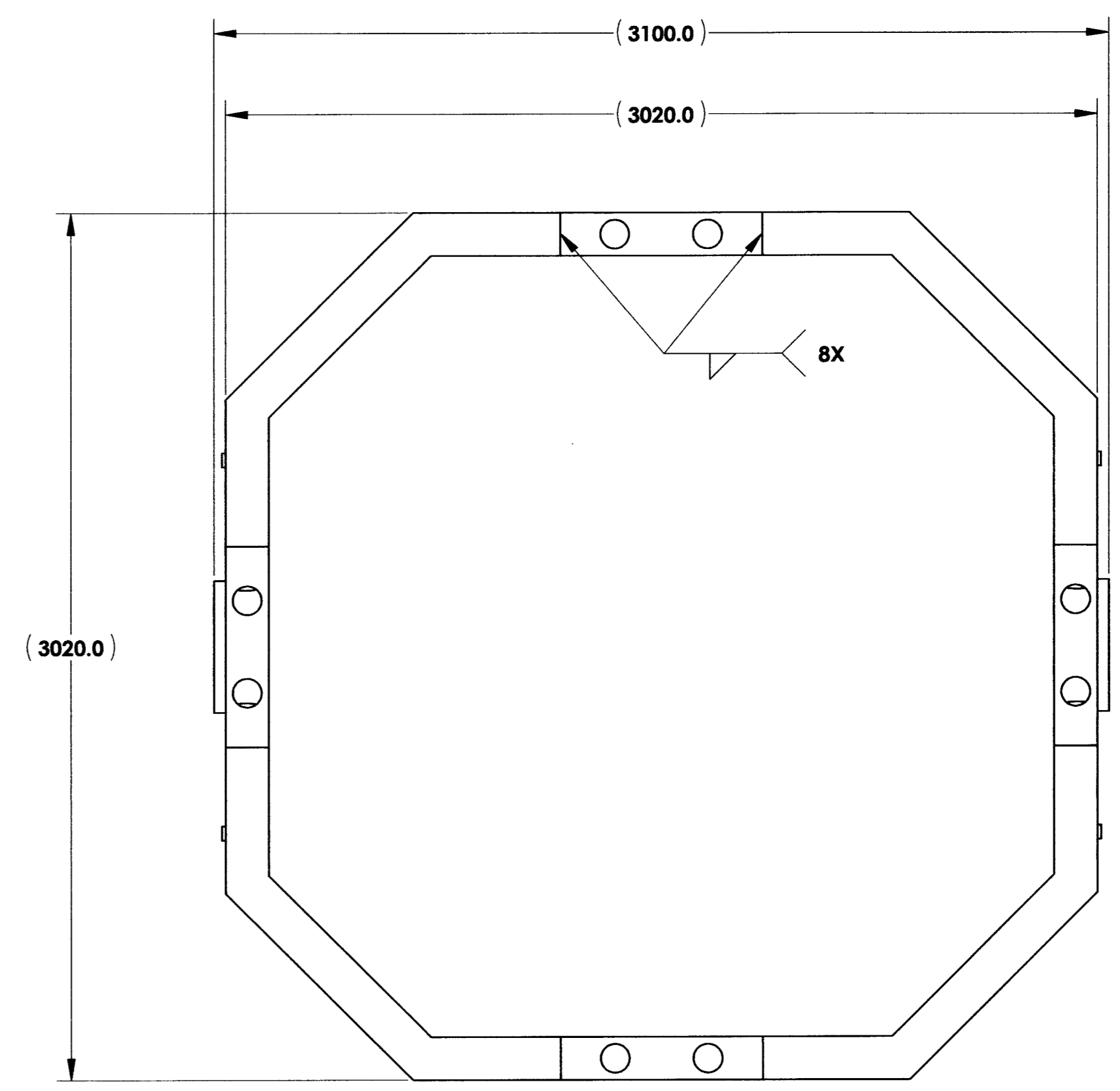
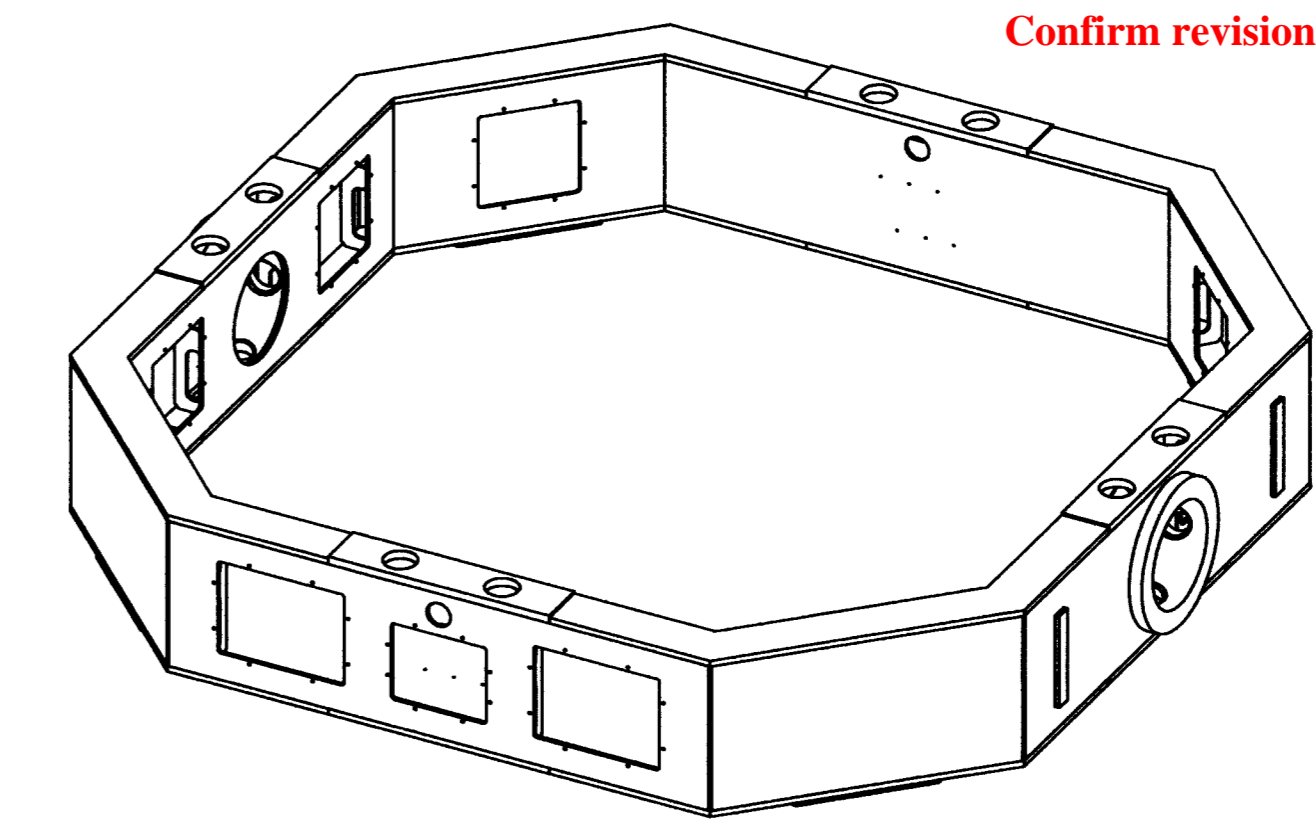
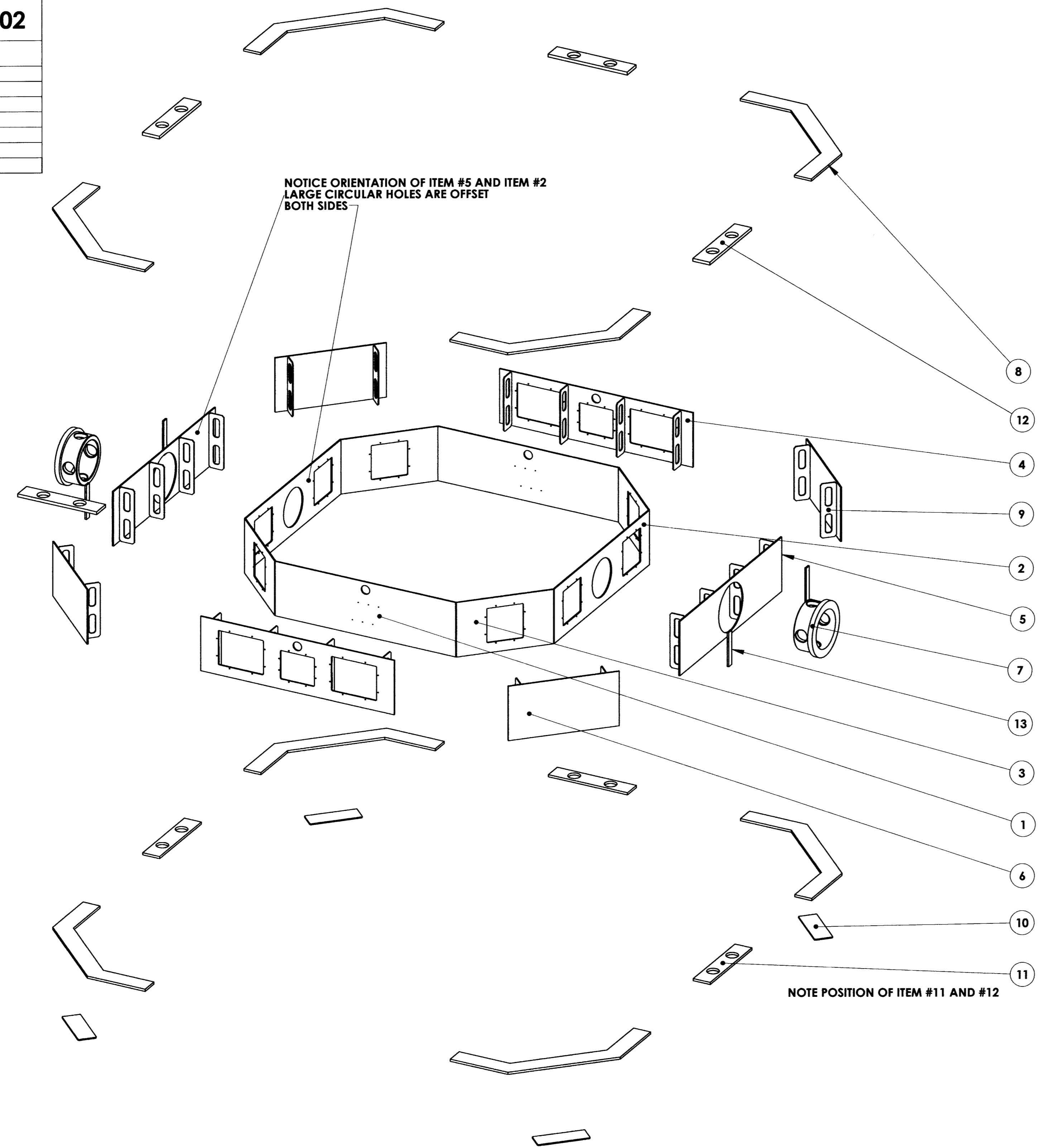

ITEM NO.	QTY.	PART NUMBER	DESCRIPTION	MATERIAL	WEIGHT
13	4	COM-5727	ENCODER RING MOUNT	ASTM A-36 STEEL	1486
12	4	COM-5723	INTERFACE PLATE 1	ASTM A-36 STEEL	17691
11	4	COM-5724	INTERFACE PLATE 2	ASTM A-36 STEEL	13268
10	4	COM-5725	INTERFACE PLATE 3	ASTM A-36 STEEL	4787
9	24	COM-5722	SUPPORT RIB	ASTM A-36 STEEL	2260
8	8	COM-5720	END PLATE	ASTM A-36 STEEL	40452
7	2	COM-5721	SUPPORT RING	ASTM A-36 STEEL	66290
6	4	COM-5719	OUTER PLATE 3	ASTM A-36 STEEL	32107
5	2	COM-5718	OUTER PLATE 2	ASTM A-36 STEEL	50732
4	2	COM-5717	OUTER PLATE 1	ASTM A-36 STEEL	36580
3	4	COM-5716	INNER PLATE 3	ASTM A-36 STEEL	21360
2	2	COM-5715	INNER PLATE 2	ASTM A-36 STEEL	36754
1	2	COM-5714	INNER PLATE 1	ASTM A-36 STEEL	56006

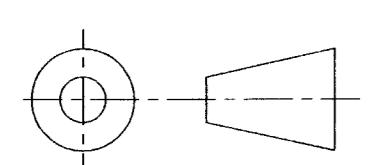

DO NOT SCALE DRAWING

COPYRIGHT

THIS DOCUMENT & ENCLOSED PROPRIETARY INFORMATION REMAINS THE PROPERTY OF EOS TECHNOLOGIES, INC. THE INTELLECTUAL PROPERTY AND INFORMATION HEREIN MAY NOT BE COPIED NOR DISCLOSED WITHOUT WRITTEN CONSENT OF EOS TECHNOLOGIES, INC. MANAGEMENT

UNLESS OTHERWISE SPECIFIED:
DIMENSIONS ARE IN MILLIMETERS
X.X = ±0.25MM
X.XX = ±0.10MM
ANGLES = ±0.5°
ROUNDS AND FILLETS ARE R3.0
BREAK ALL SHARP EDGES 0.25MM X 0.25MM

WELDS ARE: MAX SIZE FILLET OR FULL PENETRATION GROOVE WELD AS APPROPRIATE.
ALL WELDS ARE CONTINUOUS
NEAREST NOMINAL STOCK SIZE MAY BE SUBSTITUTED UPON APPROVAL.
INDICATED MACHINED SURFACES 3.2

DESIGN	M NICKERSON	DATE	07/06/04
DRAWN	R ROBLES	DATE	07/06/04
CHECKED	K. WASMER	DATE	2-1-05
APPROVED	G. PENTLAND	DATE	2-1-05

EOS TECHNOLOGIES, INC. 3160 E. TRANSCON WAY, SUITE 180, TUCSON, AZ 85706 PH: (520) 624-6399			
TITLE CENTER SECTION WELDMENT			
DRAWING NO.	ASY-5712	STATUS	Released
SCALE	1:20	REVISION	REL-02
SHEET	1 OF 2	SHEET SIZE	A1