

DRAWING NO. ASY-5737	REVISION REL-01
PROJECT CODE: LICK-51	
REQUIRED PER TELESCOPE: 1	
MATERIAL: PER COMPONENT	
CONDITION: AS SUPPLIED	
SURFACE FINISH: SEE DOCUMENT 6400/340HP SERIES 6/01	
FINISH COLOR: WHITE	
APPROXIMATE MASS: 986891.88070326 gm	
REFERENCE DOCUMENTS:	

NOTES:
 1) ALL CORNER JUNCTIONS MUST BE COMPLETELY FILLED.
 2) ALL WELDS AND WELD PREPS SHALL BE COMPLETED IN ACCORDANCE WITH THE CURRENT AISC MANUAL OF STEEL CONSTRUCTION

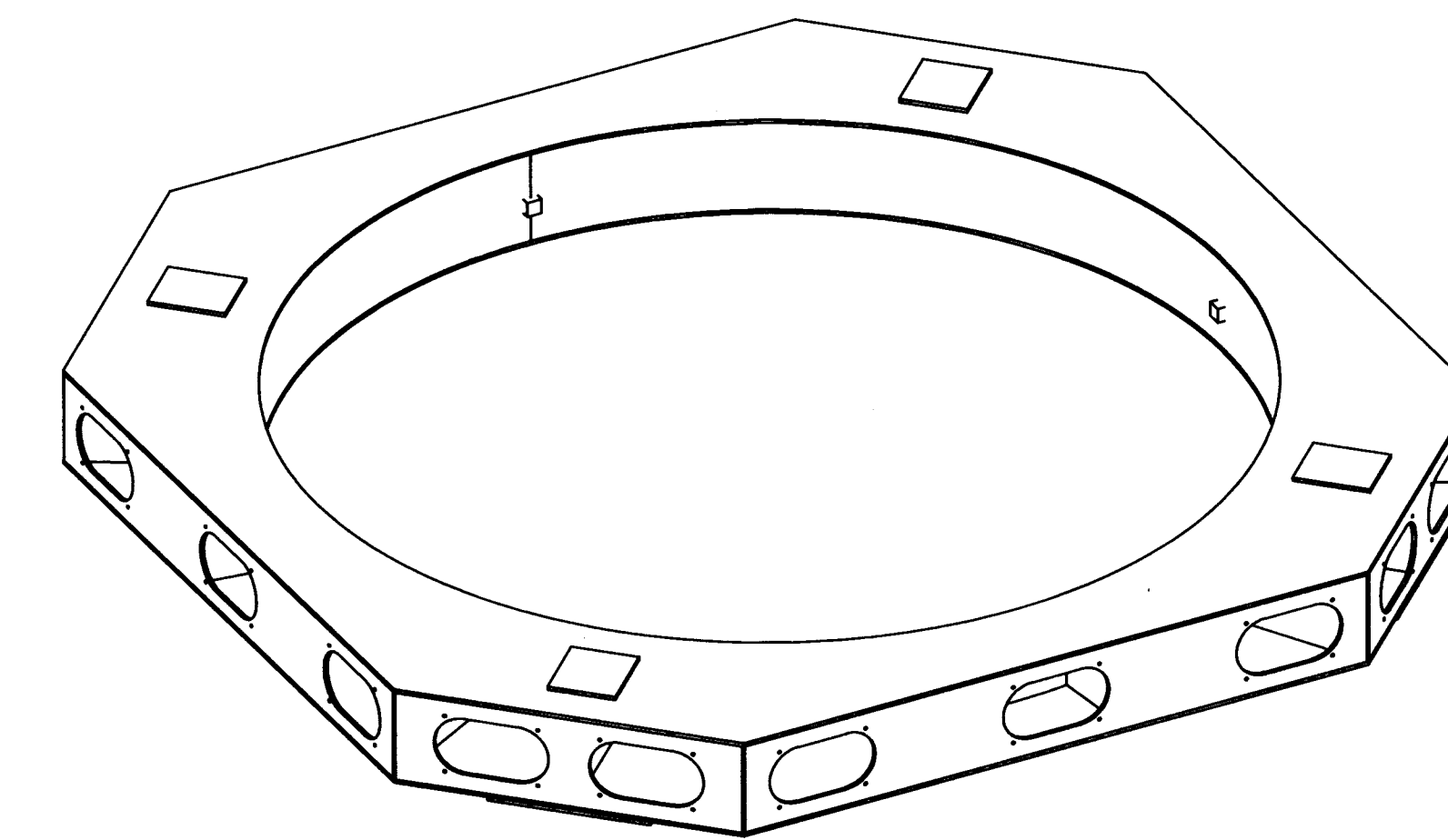
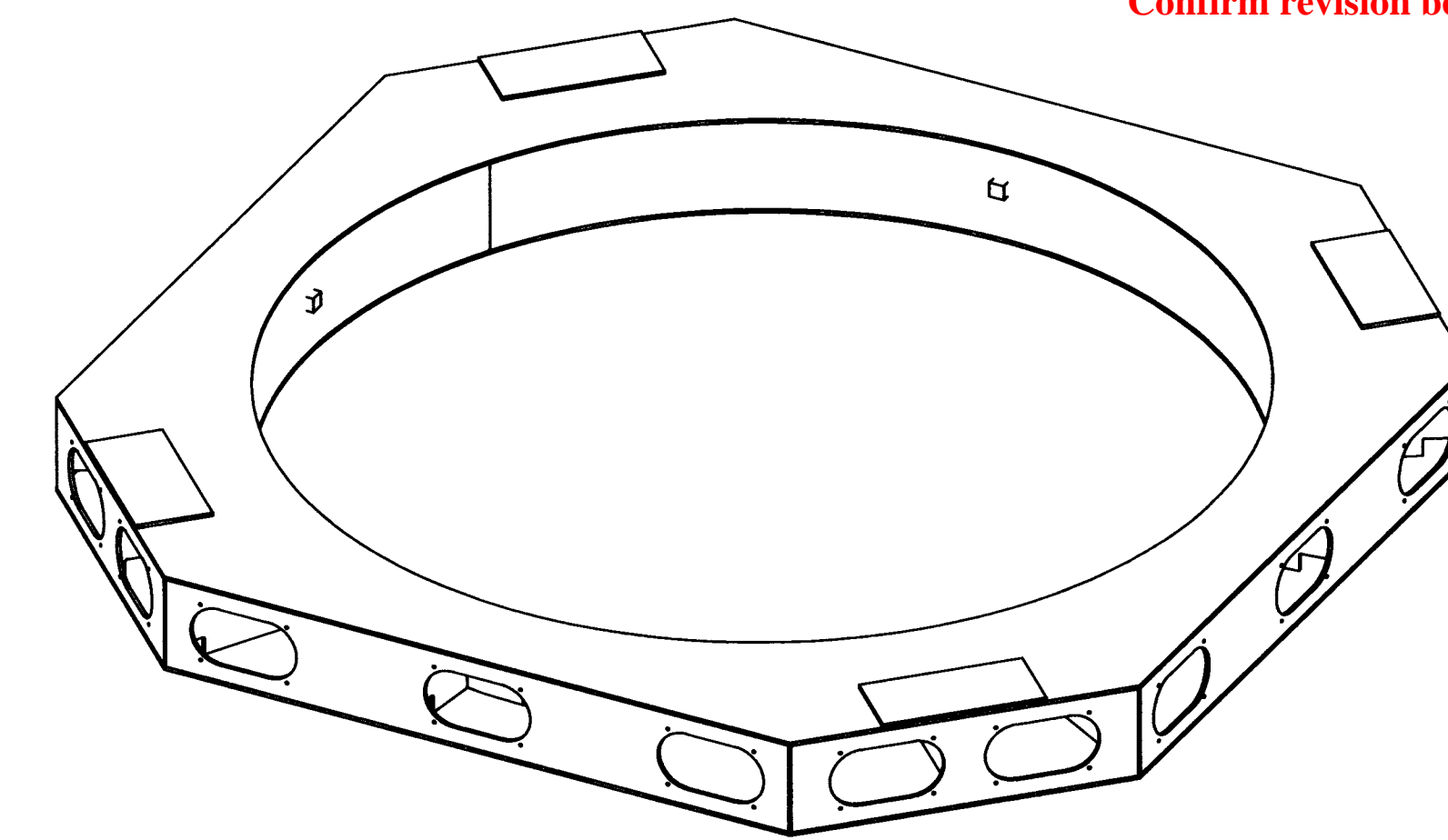
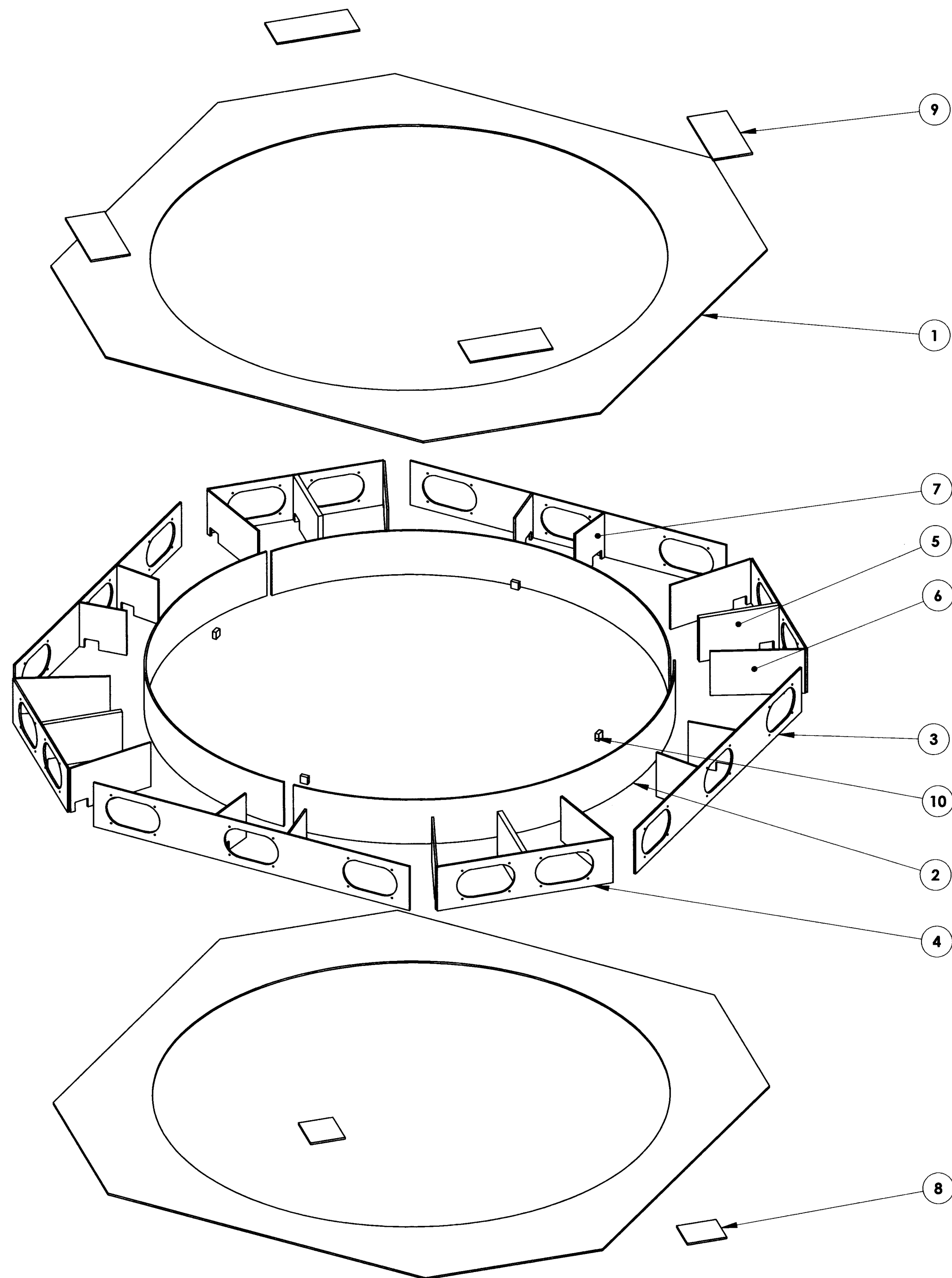

Controlled Document
 Confirm revision before using

ITEM NO.	EXP/QTY.	PART NUMBER	DESCRIPTION	Material	Weight
10	4	COM-5749	LSF PLATE 11	ASTM A-36 STEEL	238
9	4	COM-5747	LSF PLATE 9	ASTM A-36 STEEL	6241
8	4	COM-5746	LSF PLATE 8	ASTM A-36 STEEL	2600
7	8	COM-5745	LSF PLATE 7	ASTM A-36 STEEL	4250
6	8	COM-5744	LSF PLATE 6	ASTM A-36 STEEL	8276
5	4	COM-5743	LSF PLATE 5	ASTM A-36 STEEL	19340
4	4	COM-5742	LSF PLATE 4	ASTM A-36 STEEL	10376
3	4	COM-5741	LSF PLATE 3	ASTM A-36 STEEL	22868
2	3	COM-5740	LSF PLATE 2	ASTM A-36 STEEL	49103
1	2	COM-5739	LSF PLATE 1	3/8" A-36 STEEL PLATE	246362

DO NOT SCALE DRAWING

COPYRIGHT

THIS DOCUMENT & ENCLOSED PROPRIETARY INFORMATION REMAINS THE PROPERTY OF EOS TECHNOLOGIES, INC. THE INTELLECTUAL PROPERTY AND INFORMATION HEREIN MAY NOT BE COPIED NOR DISCLOSED WITHOUT WRITTEN CONSENT OF EOS TECHNOLOGIES, INC. MANAGEMENT

UNLESS OTHERWISE SPECIFIED:
 DIMENSIONS ARE IN MILLIMETERS
 X.X = ±0.25MM
 X.XX = ±0.10MM
 ANGLES = ±0.5°
 ROUNDS AND FILLETS ARE R3.0
 BREAK ALL SHARP EDGES 0.25MM X 0.25MM

WELDS ARE: MAX SIZE FILLET OR FULL PENETRATION GROOVE WELD AS APPROPRIATE.
 ALL WELDS ARE CONTINUOUS
 NEAREST NOMINAL STOCK SIZE MAY BE SUBSTITUTED UPON APPROVAL.
 INDICATED MACHINED SURFACES 3.2

DESIGN M NICKERSON	DATE 7-6-04
DRAWN K. WASMER	DATE 1-25-05
CHECKED <i>S. Dale</i>	DATE 2/10/25
APPROVED <i>E. J. Pennington</i>	DATE FEB 11 2005

EOS TECHNOLOGIES, INC.
 3160 E. TRANSCON WAY, SUITE 180, TUCSON, AZ 85706 PH: (520) 624-6399

LSF WELDMENT

DRAWING NO. **ASY-5737** STATUS **Released** REVISION **REL-01** SHEET SIZE **A1**

SCALE **1:16** SHEET **1 OF 2**