

DRAWING NO. ASY-5764	REVISION REL-02
PROJECT CODE: LICK-51	
REQUIRED PER TELESCOPE: 1 TOTAL PER TELESCOPE	
MATERIAL: PER COMPONENT	
CONDITION: PER COMPONENT	
FINISH: PER COMPONENT	
FINISH COLOR: PER COMPONENT	
APPROXIMATE MASS: 200526.81 gm	
REFERENCE DOCUMENTS:	

REV.	DATE	DESCRIPTION	CHK'D	APPV'D	ZONE
1	12/14/2005	INITIAL RELEASE	KG	KG	
2	9/26/2006	ECO-0811	<i>u</i>	<i>u</i>	

Controlled Document
Confirm revision before using

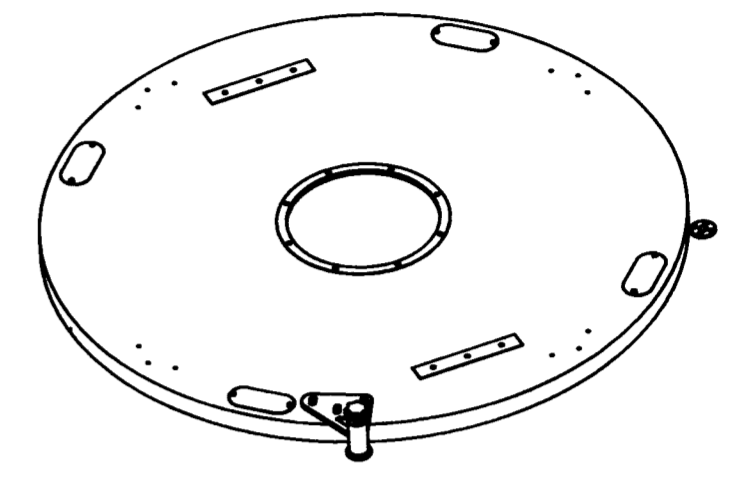
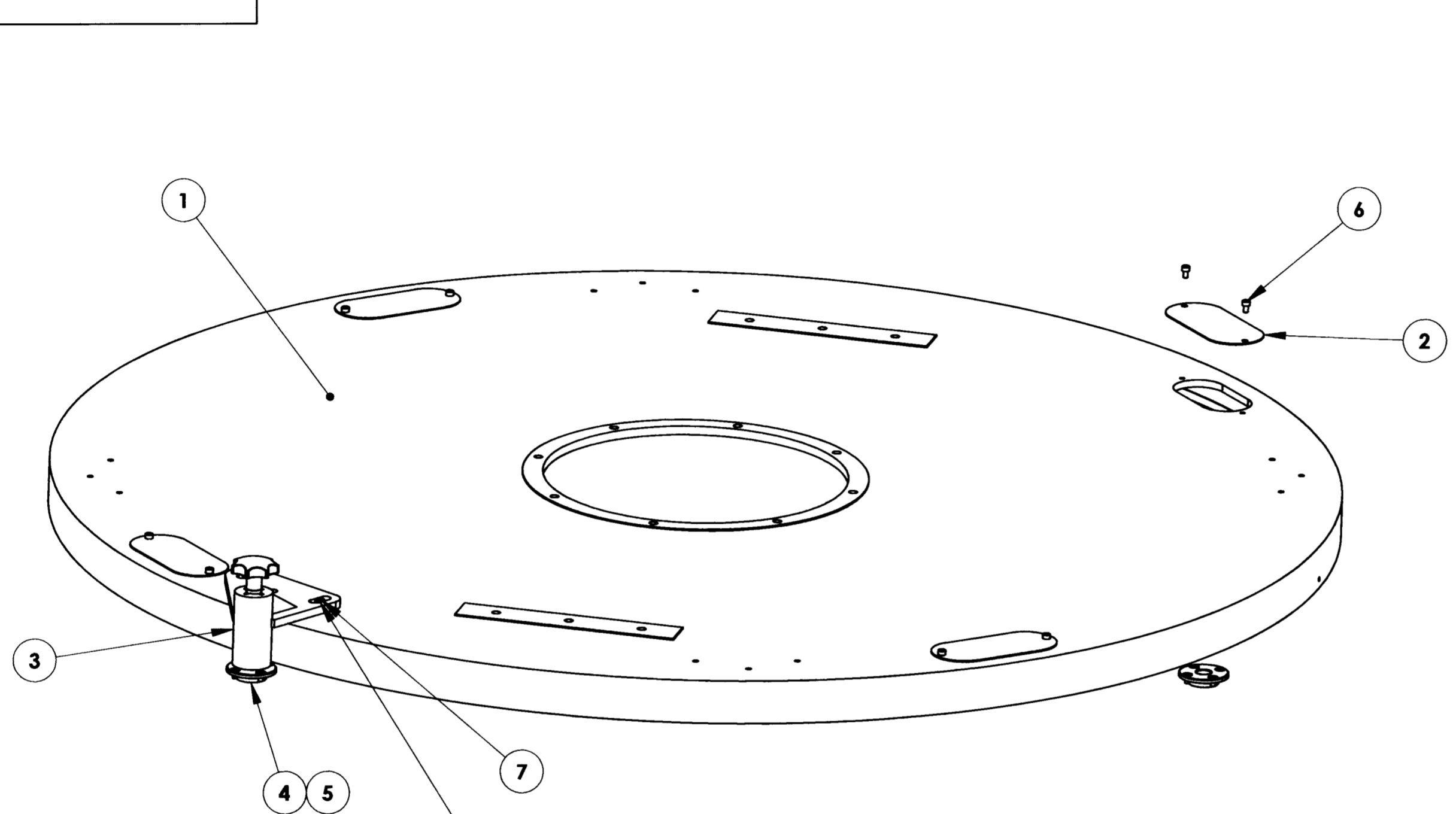

DO NOT USE SCREWS ANY LONGER THAN SPECIFIED. CHECK TO SEE THAT SCREWS DO NOT PROTRUDE PAST PLATE.

ITEM NO.	Default/QTY.	PART NUMBER	DESCRIPTION	Material	Weight
7	3	B18.3.1M - 8 x 1.25 x 12 Hex SHCS -- 12NHX			
6	8	B18.3.1M - 6 x 1.0 x 10 Hex SHCS -- 10NHX			
5	8	DIN 7991 - M6 x 12 --- 5.7N			
4	2	COM-5809	STAYPIN RECEIVER	304 STAINLESS STEEL	189
3	1	ASY-5797	STAYPIN BRACKET ASSEMBLY	N/A	0
2	4	COM-5767	ALTITUDE DRIVE RING COVER PLATE	1/16" AISI 304 STAINLESS STEEL	164
1	1	COM-5765	ALTITUDE ENCODER RING	AISI 410 STAINLESS STEEL	195892.5294

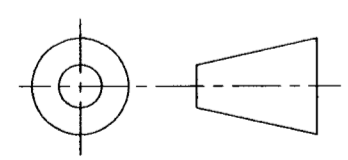

DO NOT SCALE DRAWING

<p>COPYRIGHT</p> <p>THIS DOCUMENT & ENCLOSED PROPRIETARY INFORMATION REMAINS THE PROPERTY OF EOS TECHNOLOGIES, INC. THE INTELLECTUAL PROPERTY AND INFORMATION HEREIN MAY NOT BE COPIED NOR DISCLOSED WITHOUT WRITTEN CONSENT OF EOS TECHNOLOGIES, INC. MANAGEMENT</p>	<p>UNLESS OTHERWISE SPECIFIED: DIMENSIONS ARE IN MILLIMETERS TOLERANCES: X.X = ±0.25MM X.XX = ±0.10MM ANGLES = ±0.5° ROUNDS AND FILLETS ARE R3.0 BREAK ALL SHARP EDGES 0.25MM X 0.25MM</p>	<p>WELDS ARE: MAX SIZE FILLET OR FULL PENETRATION GROOVE AS APPROPRIATE. ALL WELDS ARE CONTINUOUS NEAREST NOMINAL STOCK SIZE MAY BE SUBSTITUTED. INDICATED MACHINED SURFACES</p>	DESIGN	J. CATONE	DATE	9/14/04	<p>EOS TECHNOLOGIES, INC. 3160 E. TRANSCON WAY, SUITE 180, TUCSON, AZ 85706 PH: (520) 624-6399</p>						
			DRAWN	J. CATONE	DATE	9/14/04							
			CHECKED	K. GONZALES	DATE	12/14/05							
			APPROVED	K. GONZALES	DATE	12/14/05							
			<p>ALTITUDE ENCODER RING ASSEMBLY</p>		DRAWING NO.		<p>ASY-5764</p>	STATUS		<p>REL-02</p>	SHEET SIZE		<p>A2</p>
					SHEET 1 OF 1			SCALE 1:6					