

DRAWING NO. ASY-5916	REVISION REL-02
PROJECT CODE: LICK-51	

Controlled Document
Confirm revision before using

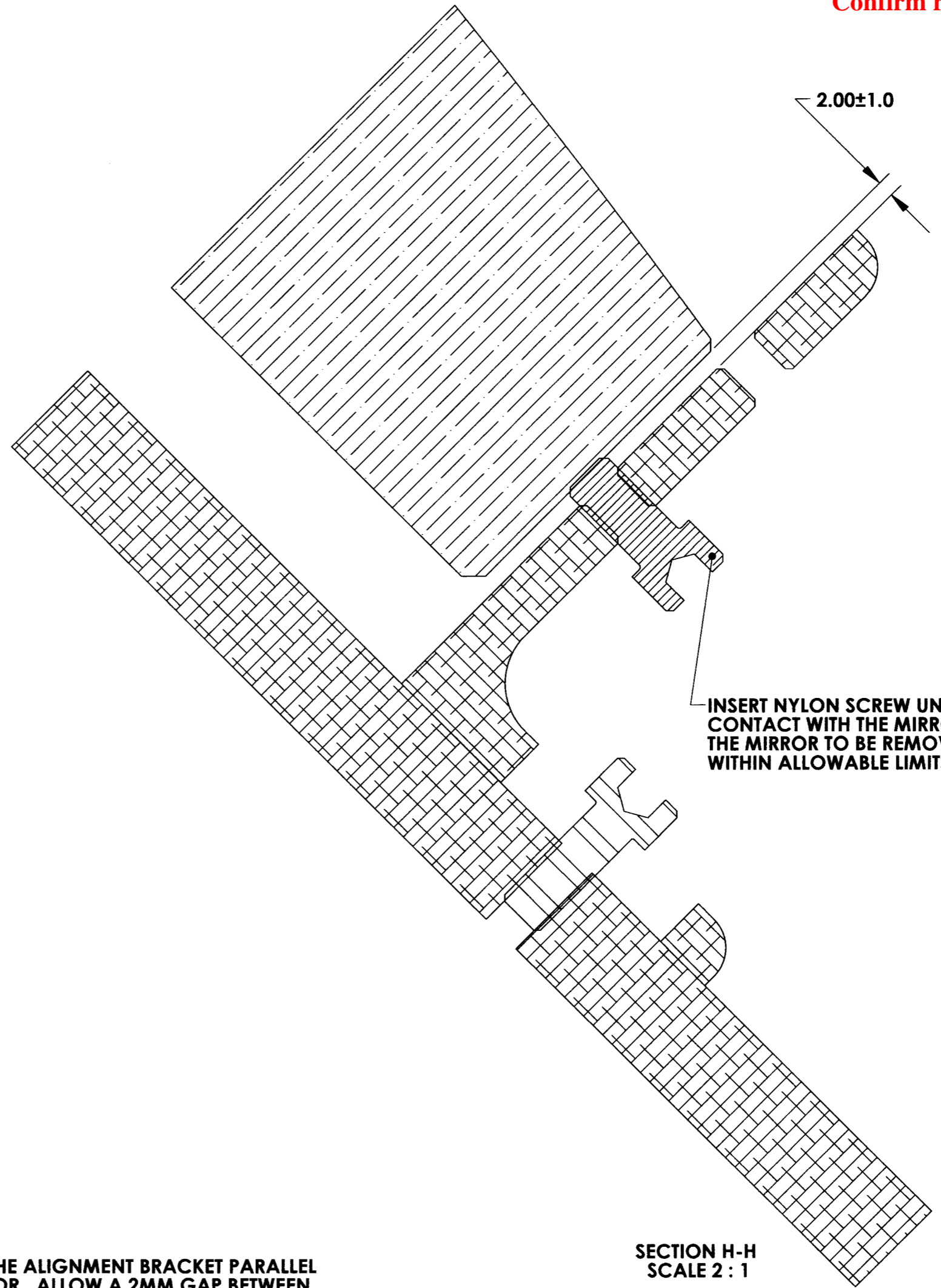
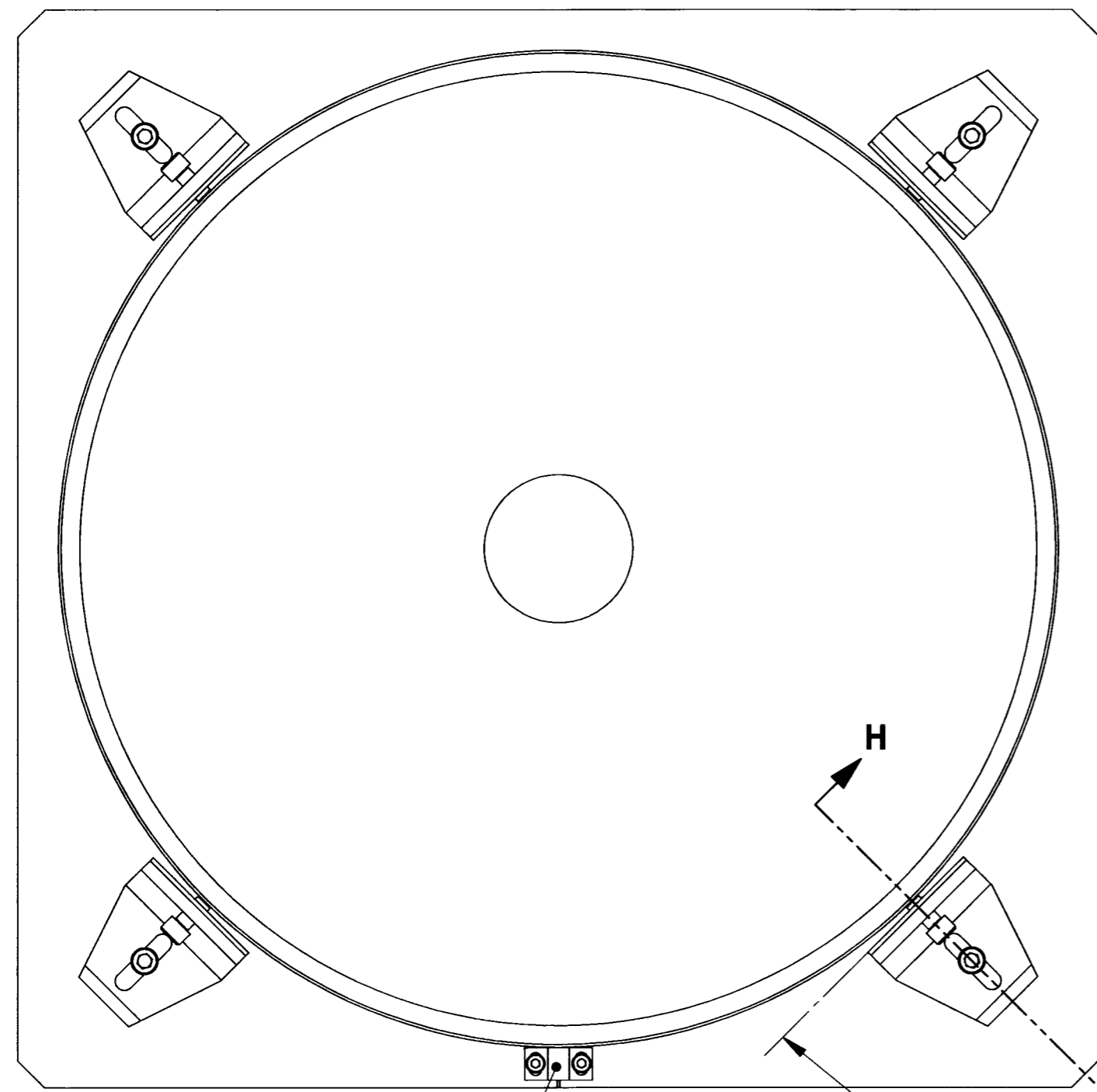

INSERT NYLON SCREW UNTIL IT JUST MAKES CONTACT WITH THE MIRROR. THIS WILL ALLOW THE MIRROR TO BE REMOVED AND REPLACED WITHIN ALLOWABLE LIMITS

SECTION H-H
SCALE 2 : 1

MAKE SURE THIS ALIGNMENT TOOL IS CONTACTING THE MIRROR

ALIGN THIS SURFACE OF THE ALIGNMENT BRACKET PARALLEL TO THE TANGENT OF THE MIRROR. ALLOW A 2MM GAP BETWEEN THE MIRROR AND THE BRACKET. TIGHTLY FASTEN THE BRACKET TO THE FIXTURE PLATE BY SECURING THE TIE-DOWN SCREW. (DO NOT USE THREAD LOCKING COMPOUND)

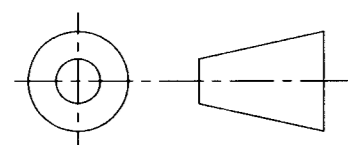

DO NOT SCALE DRAWING
DIMENSIONS IN MILLIMETERS

<p>COPYRIGHT</p> <p>THIS DOCUMENT & ENCLOSED PROPRIETARY INFORMATION REMAINS THE PROPERTY OF EOS TECHNOLOGIES, INC. THE INTELLECTUAL PROPERTY AND INFORMATION HEREIN MAY NOT BE COPIED NOR DISCLOSED WITHOUT WRITTEN CONSENT OF EOS TECHNOLOGIES, INC. MANAGEMENT</p>	<p>EOS TECHNOLOGIES, INC.</p> <p>3160 E. TRANSCON WAY, SUITE 180, TUCSON, AZ 85706 PH: (520) 624-6399</p>		
	<p>TITLE: M2 MIRROR ASSEMBLY</p>		
	<p>DRAWING NO. ASY-5916</p>	<p>STATUS Released</p>	<p>REVISION REL-02</p>
	<p>SCALE:1:2</p>	<p>SHEET 4 OF 5</p>	<p>SHEET SIZE A2</p>