

DRAWING NO. ASY-6672	REVISION REL-01
PROJECT CODE: LICK-51	
REQUIRED PER TELESCOPE: 3	
MATERIAL: PER COMPONENT	
CONDITION: PER COMPONENT	
FINISH: PER COMPONENT	
FINISH COLOR: PER COMPONENT	
APPROXIMATE MASS: 29.12 gm	
REFERENCE DOCUMENTS:	

REV.	DATE	DESCRIPTION	CHK'D	APP'VD	ZONE
1	3-1-05	INITIAL RELEASE	KLW	TJA	

Controlled Document
Confirm revision before using

NOTE:
ASSEMBLY DOES NOT SHOW SUPPORT STRUCTURE

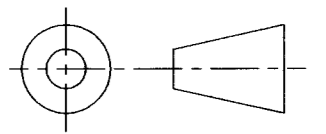
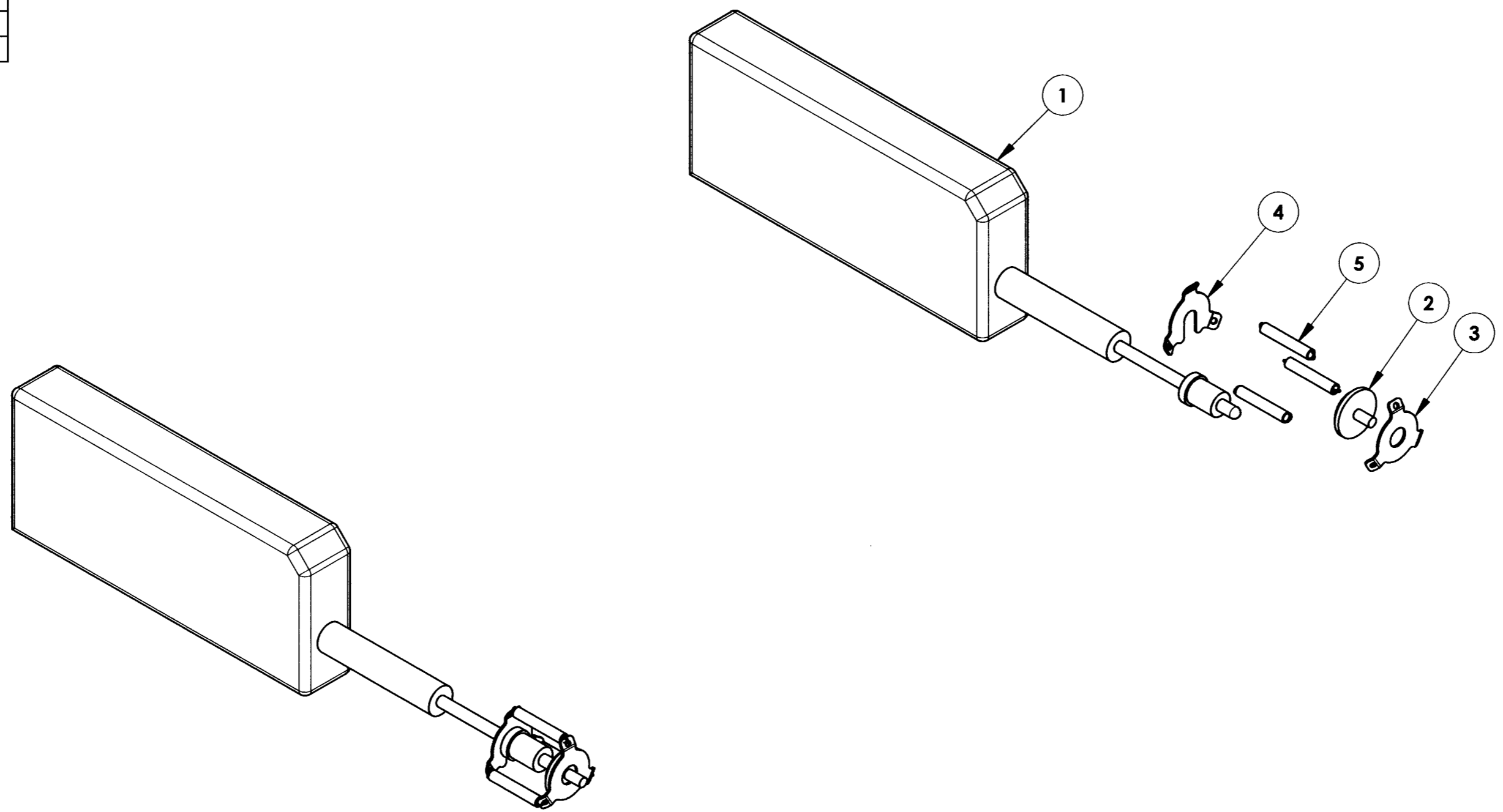

DO NOT SCALE DRAWING

ITEM NO.	QTY.	PART NUMBER	DESCRIPTION	Material	Weight
5	3	McM 9432K21	SPRING WITH HOOK ENDS	STEEL MUSIC WIRE	0.28
4	1	com-6671	M2 LOWER ENC SPRING MNT	0.5mm THK 304 SST	0.56
3	1	com-6670	M2 LOWER ENC SPRING MNT	0.5mm THK 304 SST	0.62
2	1	McM 20625A419	1/2" X 3/32" DIAL INDICATOR TIP	MCMMASTER #20625A419	2
1	1	HEIDENHAIN MT2501	LINEAR ENCODER	PER COMPONENT	25

<p>COPYRIGHT</p> <p>THIS DOCUMENT & ENCLOSED PROPRIETARY INFORMATION REMAINS THE PROPERTY OF EOS TECHNOLOGIES, INC. THE INTELLECTUAL PROPERTY AND INFORMATION HEREIN MAY NOT BE COPIED NOR DISCLOSED WITHOUT WRITTEN CONSENT OF EOS TECHNOLOGIES, INC. MANAGEMENT</p>	<p>UNLESS OTHERWISE SPECIFIED: DIMENSIONS ARE IN MILLIMETERS TOLERANCES: X.X = ±0.25MM X.XX = ±0.10MM ANGLES = ±0.5°</p> <p>ROUNDS AND FILLETS ARE R3.0</p> <p>BREAK ALL SHARP EDGES 0.25MM X 0.25MM</p>	<p>WELDS ARE: MAX SIZE FILLET OR FULL PENETRATION GROOVE AS APPROPRIATE.</p> <p>ALL WELDS ARE CONTINUOUS</p> <p>NEAREST NOMINAL STOCK SIZE MAY BE SUBSTITUTED.</p> <p>INDICATED MACHINED SURFACES \checkmark 3.2</p>	DESIGN A. LITTLE	DATE 25-JAN-05	<p>EOS TECHNOLOGIES, INC. 3140 E. TRANSCON WAY, SUITE 180, TUCSON, AZ 85706 PH: (520) 624-6399</p>
			DRAWN A. LITTLE	DATE 25-JAN-05	
			CHECKED <i>Kar W...</i>	DATE 3-1-05	
			APPROVED <i>G J Penland</i>	DATE 3-4-05	
			<p>M2 ENCODER TENSIONER ASSY</p>		
			DRAWING NO. ASY-6672	STATUS Released	REVISION REL-01
			SHEET 1 OF 1	SCALE 1:1	SHEET SIZE A2