

DRAWING NO. **ASY-7945** REVISION **REL-01**

PROJECT CODE: **LICK-51**

REQUIRED PER TELESCOPE: 1

MATERIAL: PER COMPONENT

CONDITION:

FINISH: PER COMPONENT

FINISH COLOR: PER COMPONENT

APPROXIMATE MASS: 372187.50 gm

REFERENCE DOCUMENTS:

REV.	DATE	DESCRIPTION	CHK'D	APP'VD	ZONE
1	6/17/05	INITIAL RELEASE	ETD	PN	

Controlled Document
Confirm revision before using

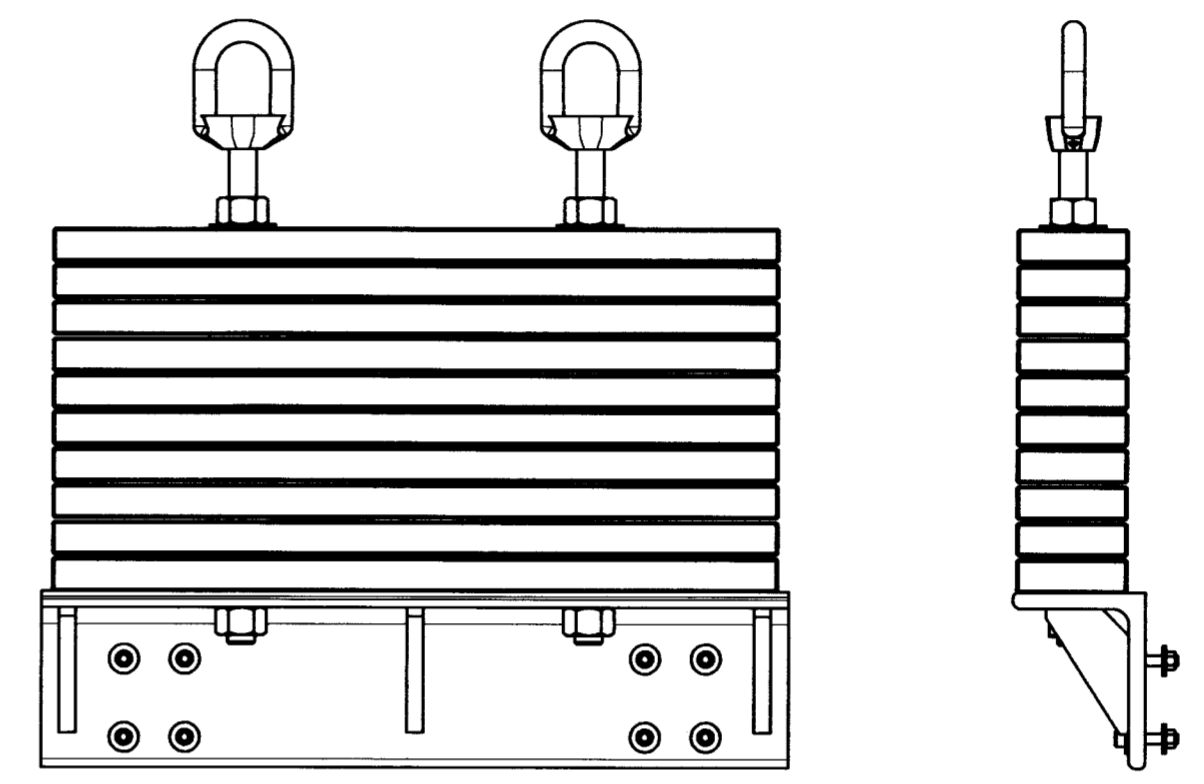
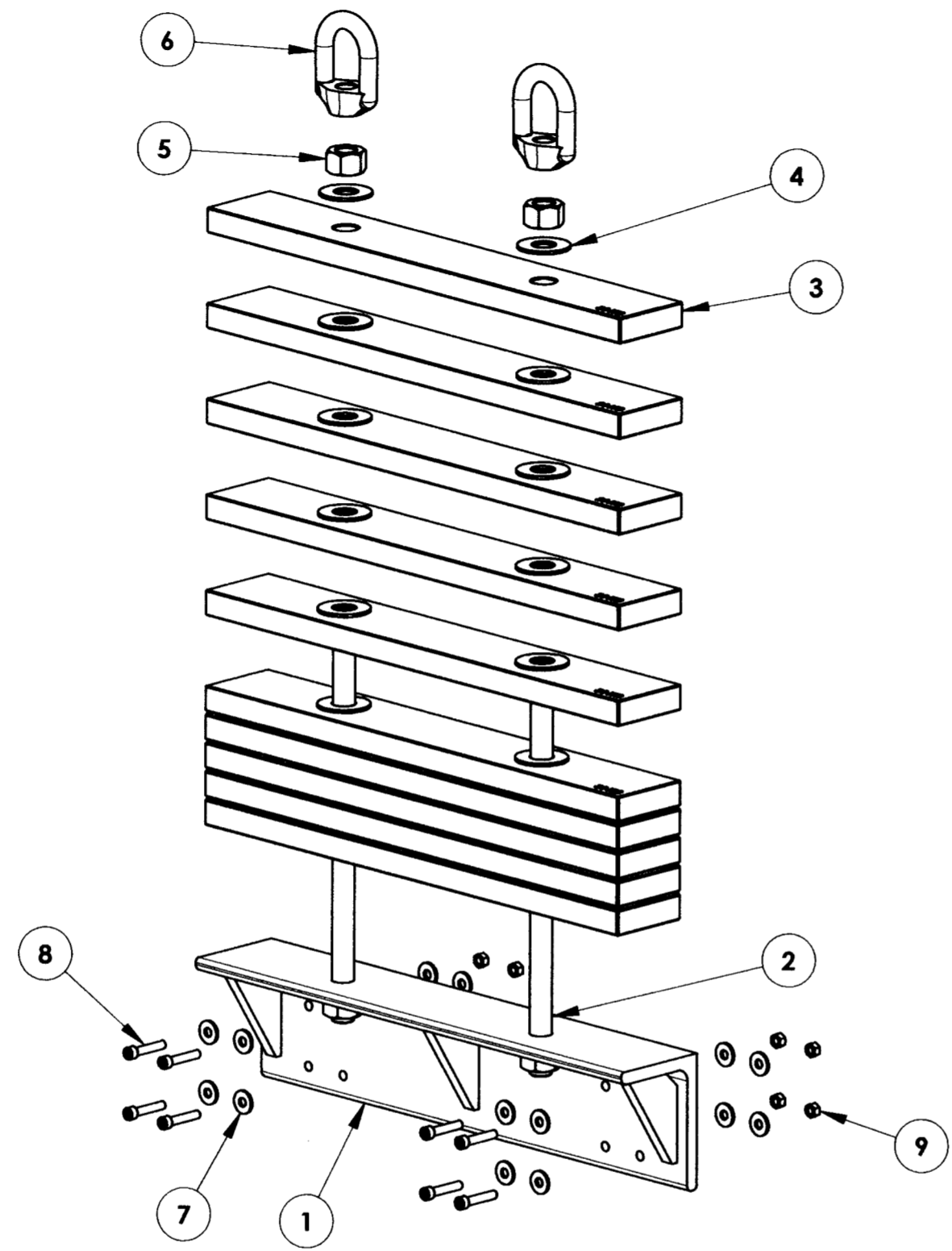

ITEM NO.	QTY.	PART NUMBER	DESCRIPTION	Material	Weight
9	8	B18.2.4.1M - Hex nut, Style 1, M12 x 1.75 --D-N			
8	8	B18.3.1M - 12 x 1.75 x 60 Hex SHCS -- 36NHX	B18.3.1M - 5 x 0.8 x 25 Hex SHCS -- 25NHX		
7	16	M12 PLAIN WASHER	M12 ANSI WASHER	ZINC PLATED ALLOY STEEL	21
6	2	3019T25			
5	2	HHNUT 1.2500-7-D-N			
4	20	FW 1.25			
3	10	COM-7940	COUNTERWEIGHT	AISI 1020	31265.31
2	2	COM-7941	COUNTERWEIGHT THREADED ROD	McMaster-Carr 98804A040	0.00
1	1	ASY-7944	COUNTERWEIGHT SUPPORT WELDMENT	PER COMPONENT	0.00

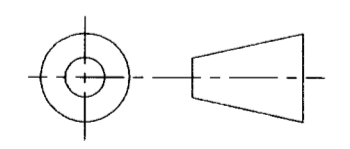

DO NOT SCALE DRAWING

<p>COPYRIGHT</p> <p>THIS DOCUMENT & ENCLOSED PROPRIETARY INFORMATION REMAINS THE PROPERTY OF EOS TECHNOLOGIES, INC. THE INTELLECTUAL PROPERTY AND INFORMATION HEREIN MAY NOT BE COPIED NOR DISCLOSED WITHOUT WRITTEN CONSENT OF EOS TECHNOLOGIES, INC. MANAGEMENT</p>	<p>UNLESS OTHERWISE SPECIFIED:</p> <p>DIMENSIONS ARE IN MILLIMETERS</p> <p>TOLERANCES:</p> <p>X.X = ±0.25MM</p> <p>X.XX = ±0.10MM</p> <p>ANGLES = ±0.5°</p> <p>ROUNDS AND FILLETS ARE R3.0</p> <p>BREAK ALL SHARP EDGES 0.25MM X 0.25MM</p>	<p>WELDS ARE:</p> <p>MAX SIZE FILLET OR FULL PENETRATION GROOVE AS APPROPRIATE.</p> <p>ALL WELDS ARE CONTINUOUS</p> <p>NEAREST NOMINAL STOCK SIZE MAY BE SUBSTITUTED.</p> <p>INDICATED MACHINED SURFACES 3.2 ✓</p>	DESIGN	K. WASMER	DATE	5-6-05	<p>EOS TECHNOLOGIES, INC.</p> <p>3160 E. TRANSCON WAY, SUITE 180, TUCSON, AZ 85706 PH: (520) 624-6399</p>							
			DRAWN	K. WASMER	DATE	5-6-05		TITLE	COUNTERWEIGHT ASSEMBLY					
			CHECKED	<i>[Signature]</i>	DATE	6/13/05	DRAWING NO.	ASY-7945	STATUS	Released	REVISION	REL-01	SHEET SIZE	A2
			APPROVED	<i>[Signature]</i>	DATE	6-13-05	SHEET 1 OF 1	SCALE	1:8					