

DRAWING NO. **ASY-8436** REVISION **REL-02**

PROJECT CODE: **LICK-51**

REQUIRED PER TELESCOPE: 1

MATERIAL: PER COMPONENT

CONDITION: PER COMPONENT

FINISH: SEE DOCUMENT 6400/340HP SERIES 6/01

FINISH COLOR: CARDINAL P009-WH-04

APPROXIMATE MASS: 71125.29 gm

REFERENCE DOCUMENTS: N/A

| REV. | DATE | DESCRIPTION | CHK'D | APPVD | ZONE |
|------|----------|------------------------|-------|-------|------|
| 1 | 6/29/05 | INITIAL RELEASE | ETD | KRH | |
| 2 | 8/9/2005 | REVISED PER ECO # 0373 | | | |

Controlled Document
Confirm revision before using

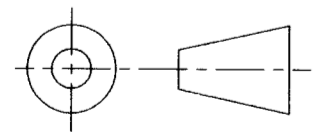
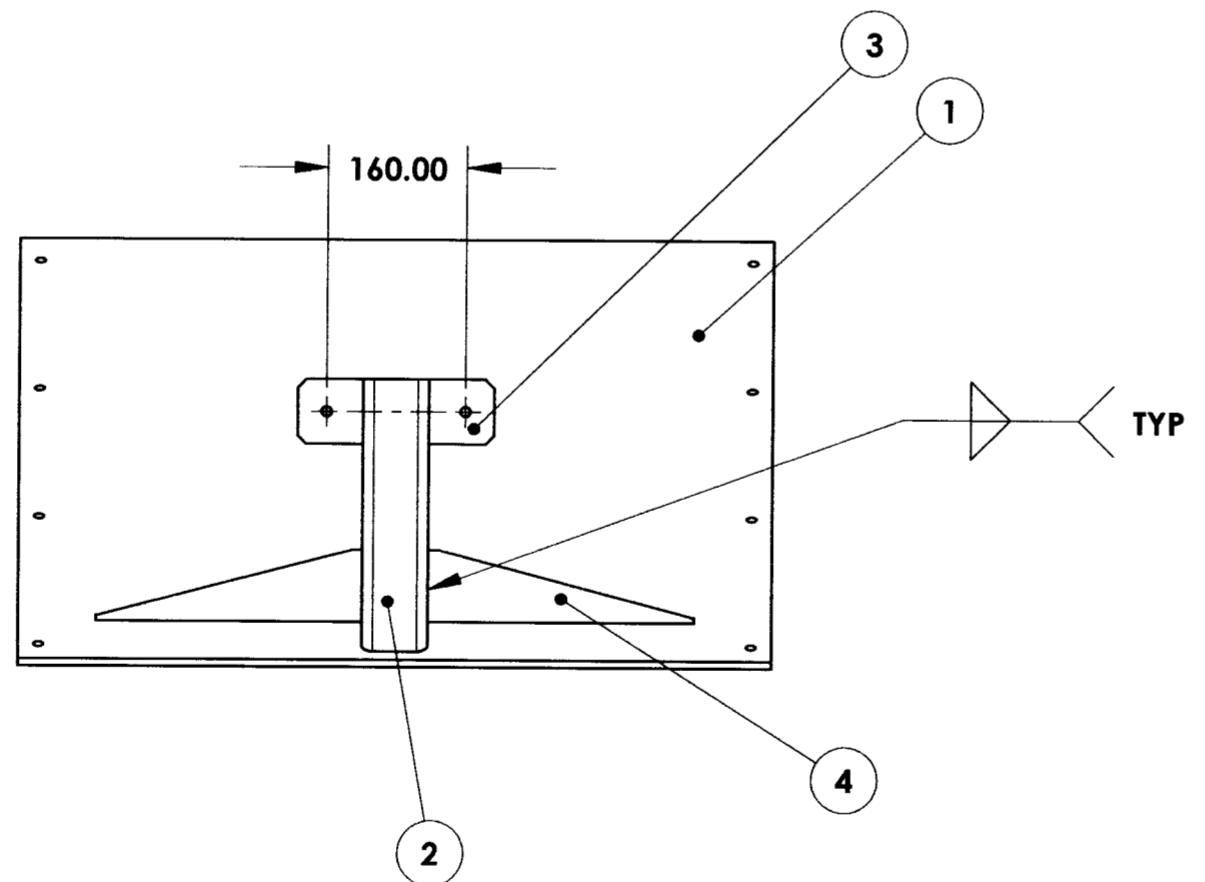
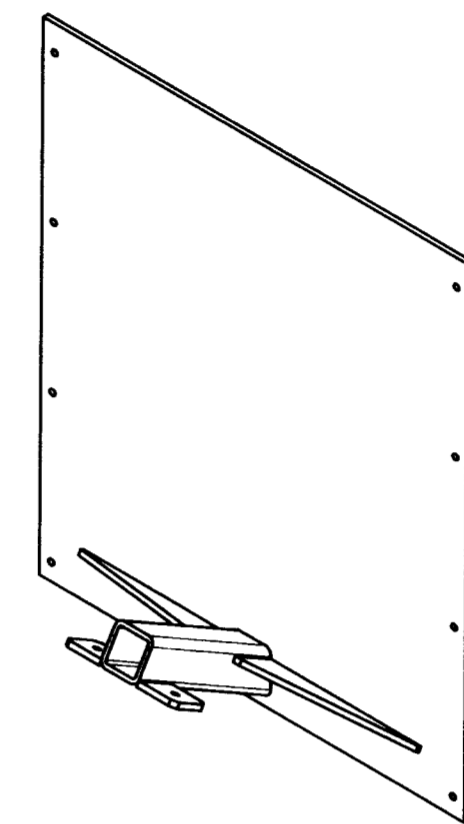
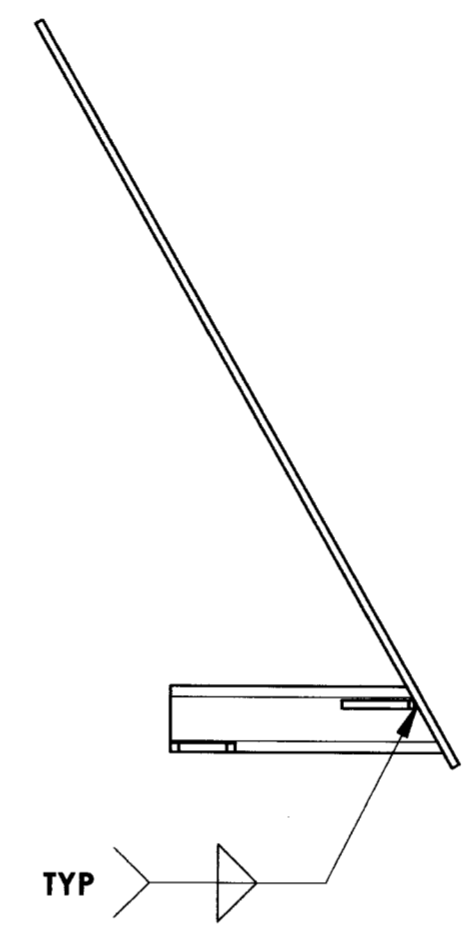
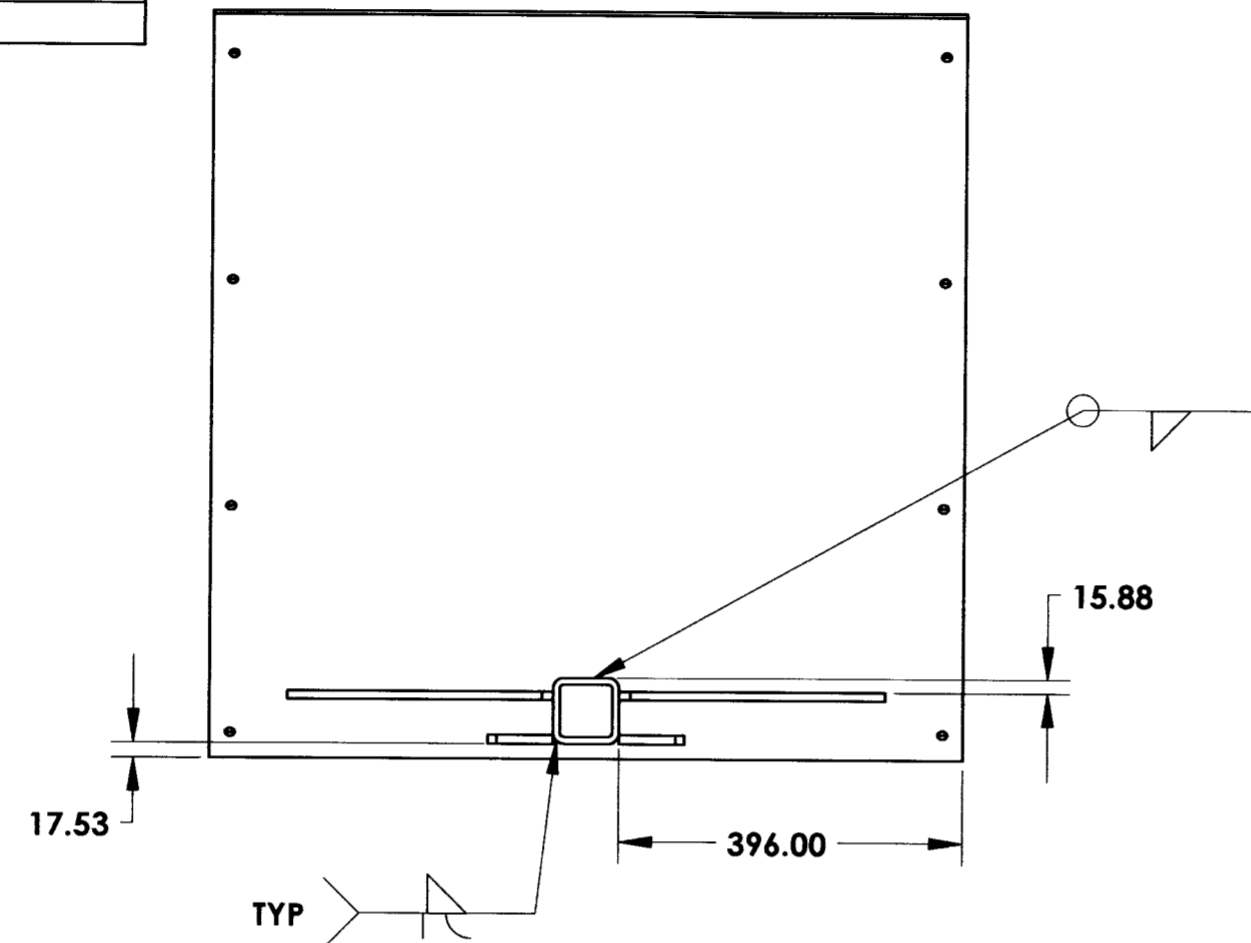

DO NOT SCALE DRAWING

| ITEM NO. | QTY. | PART NUMBER | DESCRIPTION | Material | Weight |
|----------|------|-------------|--------------------|------------------------------|----------|
| 4 | 2 | COM-8440 | TOW HITCH GUSSET | A36 Structural Steel | 1056.06 |
| 3 | 2 | COM-8439 | TOW HITCH PLATE | A36 Structural Steel | 422.85 |
| 2 | 1 | COM-8438 | TOW HITCH TUBE | CRS 3" X 3" X 5/16" SQ. TUBE | 4624.08 |
| 1 | 1 | COM-6513 | FORK BASE END SKIN | A36 Structural Steel | 63543.39 |

| | | | | | | | | | | | | |
|----------------------------------------------------------------------------------------------------------------------------------------------------------------------------------------------------------------------------------------------------------------------------------|---------------------------------------------------------------------------------------------------------------------------------------------------------------------------------------------------------------------------------------------|-----------------------------------------------------------------------------------------------------------------------------------------------------------------------------------------------------------------------------------|-------------|----------------|--------------------|---------|------------------------------------------------------------------------------------------------------------------|----------|----------|--------|------------|----|
| <p>COPYRIGHT</p> <p>THIS DOCUMENT & ENCLOSED PROPRIETARY INFORMATION REMAINS THE PROPERTY OF EOS TECHNOLOGIES, INC. THE INTELLECTUAL PROPERTY AND INFORMATION HEREIN MAY NOT BE COPIED NOR DISCLOSED WITHOUT WRITTEN CONSENT OF EOS TECHNOLOGIES, INC. MANAGEMENT</p> | <p>UNLESS OTHERWISE SPECIFIED:</p> <p>DIMENSIONS ARE IN MILLIMETERS</p> <p>TOLERANCES:</p> <p>X.X = ±0.25MM</p> <p>X.XX = ±0.10MM</p> <p>ANGLES = ±0.5°</p> <p>ROUNDS AND FILLETS ARE R3.0</p> <p>BREAK ALL SHARP EDGES 0.25MM X 0.25MM</p> | <p>WELDS ARE: MAX SIZE FILLET OR FULL PENETRATION GROOVE AS APPROPRIATE.</p> <p>ALL WELDS ARE CONTINUOUS</p> <p>NEAREST NOMINAL STOCK SIZE MAY BE SUBSTITUTED.</p> <p>INDICATED MACHINED SURFACES \checkmark 3.2</p> | DESIGN | E. DALE | DATE | 6-15-05 | <p>EOS TECHNOLOGIES, INC.</p> <p>3160 E. TRANSCON WAY, SUITE 180, TUCSON, AZ 85706 PH: (520) 624-6399</p> | | | | | |
| | | | DRAWN | K. WASMER | DATE | 6-15-05 | | | | | | |
| | | | CHECKED | E DALE | DATE | 6/29/05 | | | | | | |
| | | | APPROVED | KEVIN R HARRIS | DATE | 6/29/05 | | | | | | |
| | | | TITLE | | TOW HITCH ASSEMBLY | | | | | | | |
| | | | DRAWING NO. | | ASY-8436 | | STATUS | Released | REVISION | REL-02 | SHEET SIZE | A2 |
| | | | | | | | SHEET | 1 OF 1 | SCALE | 1:8 | | |