

|                                |                           |
|--------------------------------|---------------------------|
| DRAWING NO.<br><b>ASY-8475</b> | REVISION<br><b>REL-01</b> |
| PROJECT CODE: <b>LICK-51</b>   |                           |
| REQUIRED PER TELESCOPE: 1      |                           |
| MATERIAL: PER COMPONENT        |                           |
| CONDITION: PER COMPONENT       |                           |
| FINISH: PER COMPONENT          |                           |
| FINISH COLOR: PER COMPONENT    |                           |
| APPROXIMATE MASS: 76544.96 gm  |                           |
| REFERENCE DOCUMENTS: N/A       |                           |

| REV. | DATE   | DESCRIPTION     | CHK'D | APP'VD | ZONE |
|------|--------|-----------------|-------|--------|------|
| 1    | 2/1/05 | INITIAL RELEASE | ETD   | JP     |      |

**Controlled Document**  
**Confirm revision before using**

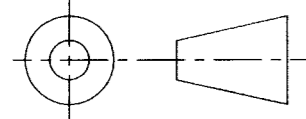
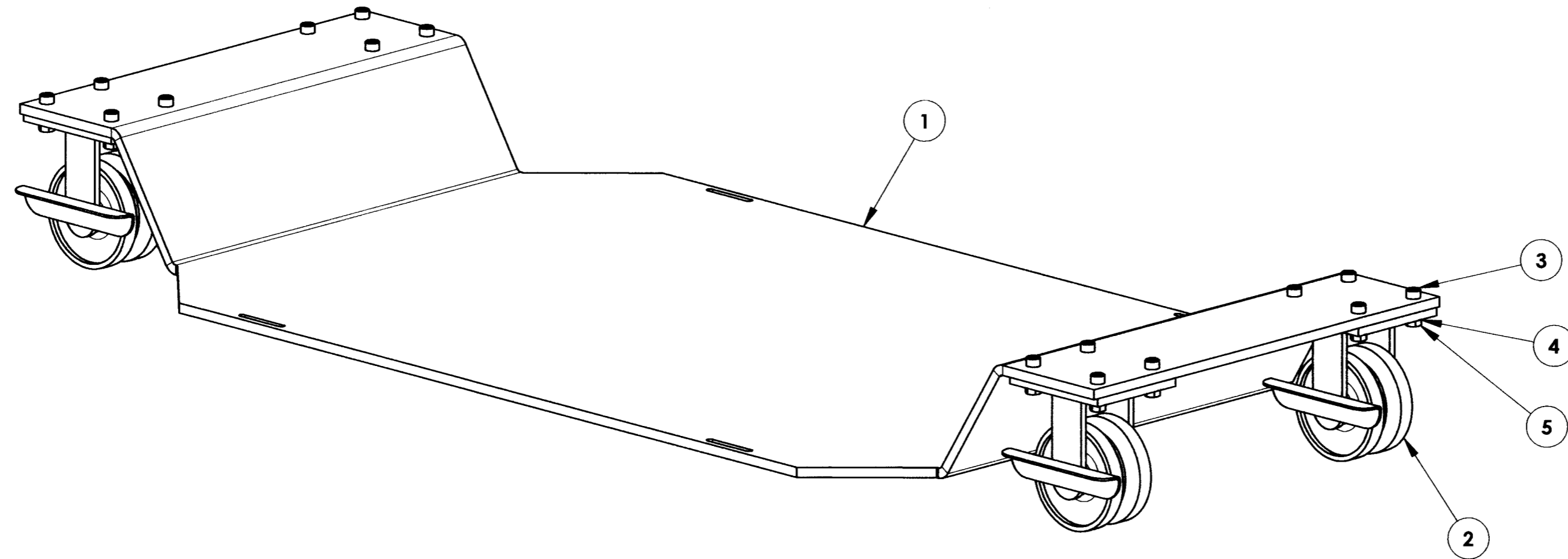

**DO NOT SCALE DRAWING**

| ITEM NO. | QTY. | PART NUMBER                                    | DESCRIPTION                  | Material                | Weight   |
|----------|------|--|------------------------------|-------------------------|----------|
| 5        | 16   | B18.2.4.1M - Hex nut, Style 1, M8 x 1.25 --D-N |                              | ZINC PLATED STEEL       |          |
| 4        | 16   | B18.22M - Plain washer, 8 mm, narrow           | M8 Plain washer, narrow      | ZINC PLATED STEEL       | 4        |
| 3        | 16   | B18.3.1M - 8 x 1.25 x 25 Hex SHCS -- 25NHX     |                              |                         |          |
| 2        | 4    | CPP-9003                                       | CASTER V-WHEEL RIGID W/BRAKE | STEEL W/CAST IRON WHEEL | 3344.91  |
| 1        | 1    | COM-8476                                       | FAN COIL CART                | A36 Structural Steel    | 62743.91 |

**COPYRIGHT**  
THIS DOCUMENT & ENCLOSED PROPRIETARY INFORMATION REMAINS THE PROPERTY OF EOS TECHNOLOGIES, INC. THE INTELLECTUAL PROPERTY AND INFORMATION HEREIN MAY NOT BE COPIED NOR DISCLOSED WITHOUT WRITTEN CONSENT OF EOS TECHNOLOGIES, INC. MANAGEMENT

**UNLESS OTHERWISE SPECIFIED:**  
DIMENSIONS ARE IN MILLIMETERS  
TOLERANCES:  
X.X = ±0.25MM  
X.XX = ±0.10MM  
ANGLES = ±0.5°  
ROUNDS AND FILLETS ARE R3.0  
BREAK ALL SHARP EDGES  
0.25MM X 0.25MM

**WELDS ARE:**  
MAX SIZE FILLET OR FULL PENETRATION GROOVE AS APPROPRIATE.  
**ALL WELDS ARE CONTINUOUS**  
NEAREST NOMINAL STOCK SIZE MAY BE SUBSTITUTED.  
INDICATED MACHINED SURFACES

|          |                |      |         |
|----------|----------------|------|---------|
| DESIGN   | K. WASMER      | DATE | 6-22-05 |
| DRAWN    | K. WASMER      | DATE | 6-22-05 |
| CHECKED  | S. Jole        | DATE | 2/1/05  |
| APPROVED | E. J. Pentland | DATE | 3/2/05  |

**EOS TECHNOLOGIES, INC.**  
3160 E. TRANSCON WAY, SUITE 180, TUCSON, AZ 85706 PH: (520) 624-6399

**FAN COIL CART ASSEMBLY**

|             |          |        |          |          |        |            |    |
|-------------|----------|--------|----------|----------|--------|------------|----|
| DRAWING NO. | ASY-8475 | STATUS | Released | REVISION | REL-01 | SHEET SIZE | A2 |
|             |          | SHEET  | 1 OF 1   | SCALE    | 1:4    |            |    |