

6639 H 15620
submittals



SERVICE MANUAL

FOR

USO – Lick Observatory

941-G001

(1) ASP-15A (1) Pump

2



MANUFACTURED BY MULTISTACK

365 South Oak Street
West Salem, WI 54669
Phone: (608) 786-3400
Fax: (608) 786-3450
www.airstack.com

MULTISTACK[®]

Airstack[™]

the **leader**
in **modular chillers.**



Multistack® and Airstack™ utilize the most innovative technologies to create modular chiller systems that meet the challenging needs of today's marketplace. Our small footprint, quiet and efficient operation, and easy to install modular design make Multistack and Airstack the equipment of choice for savvy owners, contractors, and engineers.

Water-Cooled Chillers

Packaged Scroll and Reciprocating Modules

Modules are available in 20, 30 and 50-ton packages each with dual independent scroll compressors. The 50-ton module is available in a reciprocating version as well. Modules may be mix-matched and up to 12 modules may be assembled together to form chillers from 20 to 600-tons.



Large Packaged Screw Modules

Modules are available in 70 and 90-ton packages each with a single twin-screw compressor. Modules may be mix-matched and up to eight modules may be assembled together to form chillers from 70 to 720-tons.



Centrifugal Chiller Modules

Centrifugal chiller modules are available in 80-ton packages utilizing the industry's most advanced magnetic-bearing, oil-free compressor technology. The compressor shaft levitates in a near-frictionless magnetic field eliminating metal-to-metal contact. An integral variable frequency drive controls compressor speed and capacity to precisely match the load creating the most efficient modular chiller ever devised. Modules utilize R-134A refrigerant and may be assembled to form chillers from 80 to 640 tons.



Air-Cooled Packaged Chillers

Scroll Chiller Modules

Modules are available in 10, 15 and 20-ton packages each with dual scroll tandem compressor sets. Modules may be mix-matched and up to 10 modules may be assembled together to form chillers from 10 to 200-tons. Units are available with high-static condenser fans for ducted applications.



Airstack Accessory Modules

A complete line of accessory modules is available for integration into the Packaged Air-Cooled Chiller. These accessory modules include packaged pumping modules, free-cooling modules and expansion-tank/glycol feeder modules.



Water-Cooled Condensing Units

All of Multistack's Packaged Water-Cooled Chillers are available in a Water-Cooled Condensing Unit version. Most required refrigerant specialties are factory mounted within the module. Units are designed to interconnect to a field-supplied evaporator.



comfort cooling

critical cooling



Air Cooled Split-System Chillers

All of Multistack's Packaged Water-Cooled Chillers are available in an Airstack Split-System Air-Cooled version. All required refrigerant specialties (for standard ambient) are factory mounted within the indoor module. Multistack provides matching remote air-cooled condensers. Chiller systems are available from 20 to 720-tons.

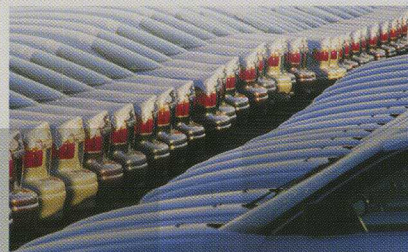

Chiller-Heaters

Water-to-Water Heat Pump

Modules are available in a 30-ton scroll and 50-ton reciprocating package each with dual independent compressors. Units are suitable for use in both closed loop and ground loop water source heat pump applications. Up to 12 modules may be assembled together to form Chiller-Heaters from 30 to 600-tons.



Dedicated Heat Recovery Chillers

Dedicated heat recovery chillers are available for many hydronic heating applications. Multistack's heat recovery chillers can produce hot water in excess of 130°F while simultaneously producing chilled water for the hydronic cooling systems. Contact your local representative for specific selection information.



So, whether you need superior redundancy, peak efficiency over a wide range of conditions, or are simply stuck with an old chiller in a tight space, Multistack and Airstack can provide guaranteed expandable solutions.

modular chillers

 **MULTISTACK®**

 **Airstack™**

The Leader in Modular Chillers

365 South Oak Street | West Salem, WI 54669
Phone 608-786-3400 | Fax 608-786-3450
www.multistack.com | www.airstack.com

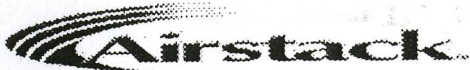

PACKAGED CHILLER

Monday, January 30, 2006

JOB NAME USO - Lick Observatory ENGINEER _____
 LOCATION _____ ARCHITECT _____
 CUSTOMER _____ CONTRACTOR _____

Multistack Order Number 941-G001 Submitted by Kurt Wessels / S.D.
 Customer P.O. Number DH20163 Approved by _____
 Sales Representative Kurt Wessels Approval Date _____

Total Number of Modules: 2.0
 Overall Height(In): 77 Width: 31 1/2 Length: 119 3/4 (Dimensions Do Not Include J-Boxes)

CHILLED WATER DESIGN

Master Module ASP-15A (MF) 1
 Slave Front ASP-__A (SF) 0
 Slave Front ASP-__A (SF) 0
 Slave Rear ASP-__A (SR) 0
 Slave Rear ASP-__A (SR) 0

Chilled Water: 22 % Ethylene Glycol
 Entering Temperature 33.0 °F
 Leaving Temperature 24.0 °F
 Flow Rate 26.5 GPM
 Evaporator ΔP 2.9 Feet

AMBIENT AIR TEMPERATURE
 Design: 95.0 °F
 Low: 0.0 °F

FULL LOAD CHILLER PERFORMANCE

Cooling Capacity: 8.7 Tons
 Power Input: 15.7 KW
 EER: 6.6

FREE COOL DESIGN

Free Cool Front ASP-00F (FF) N/A
 Free Cool Rear ASP-00F (FR) N/A
 Chilled Water:
 Entering Temp N/A °F
 Leaving Temp N/A °F
 Flow Rate (each) N/A GPM
 Total Flow Rate N/A GPM
 Operating ΔP N/A Feet
 Bypass ΔP N/A Feet

ACCESSORY MODULES

180 Gallon Tank Module(s) ASP-00T 0
 Glycol Feeder Module(s) ASP-00G 0
 Pump Module(s) ASP-00P 1

PUMP DESIGN

Pump Size (2) 1.5x1x8
 Flow Rate 26.5 GPM
 Pump 2 hp
 Total Head 52.0 Feet
 Assumes 49.1 ft of external head

CHILLER FEATURES

- Stainless Steel Evaporator
- Lead Compressor Sequencing (24hrs)
- Automatic Internal Rescheduling If Fault Occurs
- Automatic Logging Of Any Fault Condition
- Electronic Chilled Water Control
- Multiple Independent Ref. Systems
- Quick Interconnect Modular Design
- Aluminum Fin/Copper Tube Condenser Coils
- Dual Condenser Fans Per Module Designed For Quiet Operation
- Pressure Controlled 1140 RPM Fan Motors
- Filters In Evaporator Supply Headers
- R-407c Refrigerant
- 5 Year Compressor Warranty
- Single Point Power
- Expansion Tank In Pump Module
- (2) Independent Refrigerant Circuits per Module
- 5 Year Parts Warranty
- Discharge & Suction Gauges

ELECTRICAL DATA

MAIN POWER SUPPLY 230 / 60 / 3

FANS: 4 FLA per fan motor

ELECTRICAL CIRCUIT(S) CAPACITY

Minimum Circuit Ampacity (amps)
 Maximum Fuse Size (amps)
 Recommended Dual Element Fuse

CHILLER CIRCUIT*
67
91
100

ASP-15A: 23.2 RLA per compressor
 ASP-00P: 6.8 FLA per module

*All chillers require completion of at least one of these columns.

** Compressor RLA's are obtained at ARI Conditions

First Letter

M=Master Chiller Module
 S=Slave Chiller Module
 P=Pump Module
 F=Free Cool Module
 G=Glycol Feeder Module

Second Letter

F=Front Module
 R=Rear Module

CHILLER LAYOUT

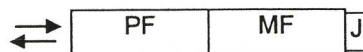

IMPORTANT: To assure full equipment design performance, life and reliability, the MULTISTACK chiller must be piped in accordance with Installation Manual unless specifically authorized otherwise by MULTISTACK in writing.

REISSUE	A	B	C	2000-0412	B
DATE	REVISION	BY	ADDED RAILS 3-25-2003 KOMPERUD	ADDED SPACER AND CHANGED 74 13/16" TO 77 5/16" 6-4-2004 PFRSS	
D					
T					

MULTISTACK		West Salem, Wisconsin 54669		SUBMITTAL	
C 2000-0412		54669		ASP MODULES	
SIMILAR TO:		ALL DIMENSIONS IN INCHES / DO NOT SCALE DRAWINGS		w/ COIL GUARDS	
C2000-0123		STD ENGR SPEC			
DRAWN BY: MWK		CHECKED BY:		SCALE: NONE	
DATE: 4-12-2000		DATE:			
CUSTOMER:					
JOB NAME:					
CONTRACTOR:					
ENGINEER:					
SALES REP:					
NOTES:					

SINGLE MODULE WEIGHT
ASP-10A = 1350 LBS.
ASP-15A = 1370 LBS.
ASP-20A = 1411 LBS.

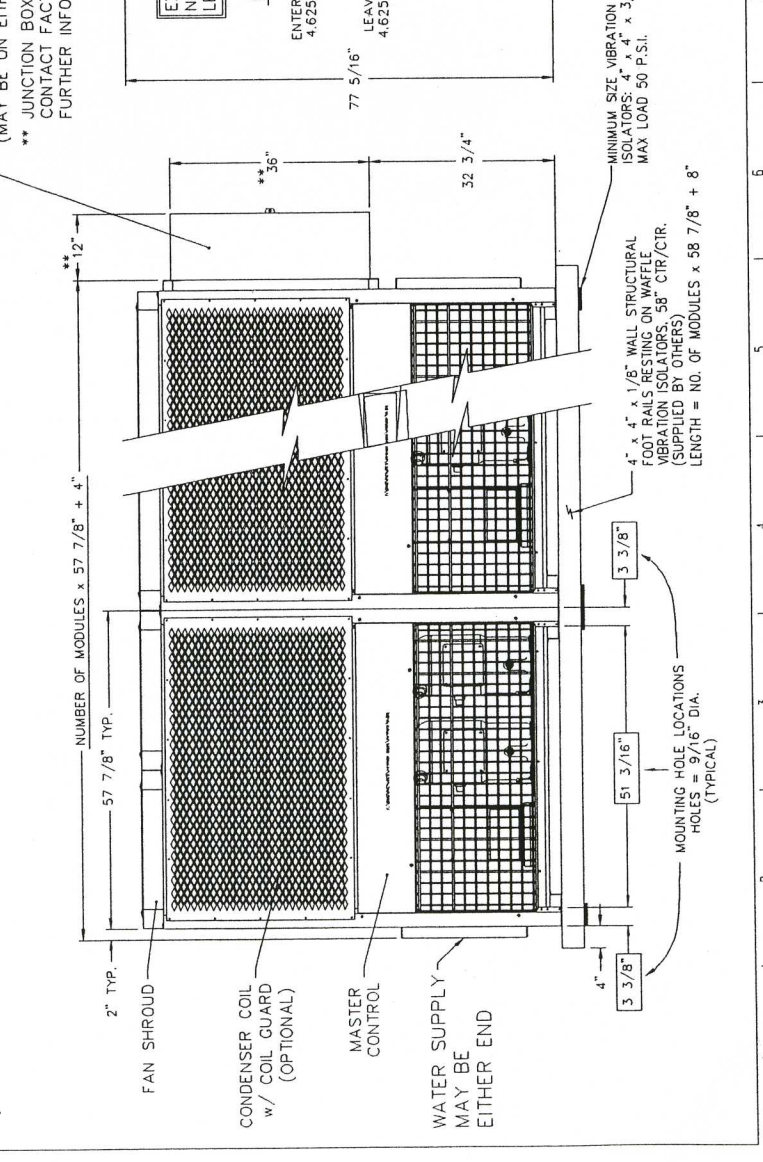
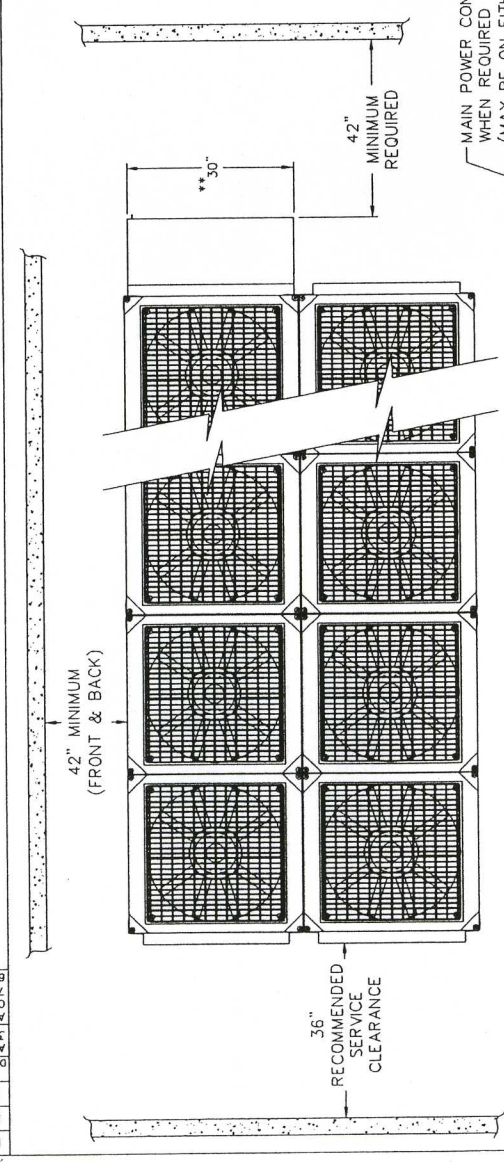

C	2000-0412
---	-----------

ARMSTRONG **Series 4280** **SUBMITTAL** 1.5x1x8 Centerline Disc. End Suction Motor Mounted Pump

Project Number:	Representative: Multistack
Name:	365 South Oak St, West Salem, WI
Reference:	Phone: 608-786-3400, Fax: 608-786-3450
Location:	Order No: Date:
Engineer:	Submitted by: Scott DeGier Date: 1/20/2006
Contractor:	Approved by: Date:

PUMP DESIGN DATA	
Tag Num:	
Service:	
Location:	
No. of Pumps:	1
Capacity:	26.5 usgpm
Head:	52 ft
Piping:	Single
Suction Pressure:	0 ft
Liquid:	Ethylene Glycol:22
Op. Temperature:	24 °F
Viscosity:	4.43 cp
Sp. Gravity:	1.03
Suction Size:	1.5 in
Discharge Size:	1 in

MOTOR DESIGN DATA	
Motor Supplier:	Factory Choice
Motor Size:	2 hp @ 1800 rpm
Frame Size:	145JM
Enclosure:	ODP
Cycle/Phase/Voltage:	60/3/230
Motor Eff:	Std
Insulation:	Class "B" Insulation (266.0 °F)
Starter Config:	DOL
Full Load/Starting (A)	6.8 / 50.0

MATERIALS OF CONSTRUCTION	
Construction	BF (Bronze Fitted)
ANSI Flange Rating	125 lb. (Cast Iron)
Impeller	Bronze (B584-844)
Casing	Cast Iron (A48-30)
Casing Gasket	Confined Non-Asbestos Fiber
Adapter	Cast Iron (A278-30)
Motor Shaft	Carbon Steel
Shaft Sleeve	Bronze (B584-844)

MECHANICAL SEAL DESIGN DATA	
Manufacturer	John Crane
Manu. Code [JC 21]	JC 21, OP171
Seal Type	Inside Unbalanced
Rotating Face	Carbon
Stationary Seat	Ceramic
Secondary Seal	EPDM
Springs	Stainless Steel
Rotating Hardware	Stainless Steel

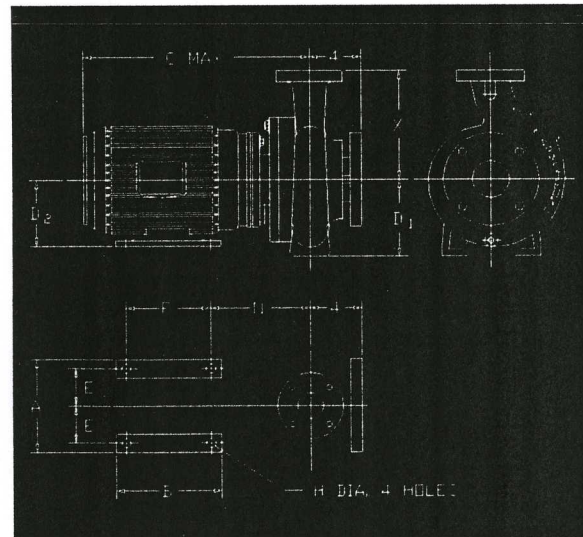
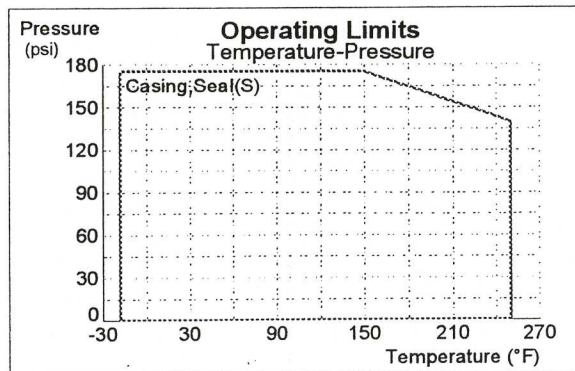

DIMENSIONAL DATA (in, lbs, hp) NOT for CONSTRUCTION											
A	B	Cmax	D1	D2	E	F	N	H	X	TotWgt	Wgt.
7	6	14	5.25	3.5	2.75	5	6.63	0.34	6.5	99	99

ARMSTRONG Series 4280
SUBMITTAL 1.5x1x8 Centerline Disc. End Suction Motor Mounted Pump

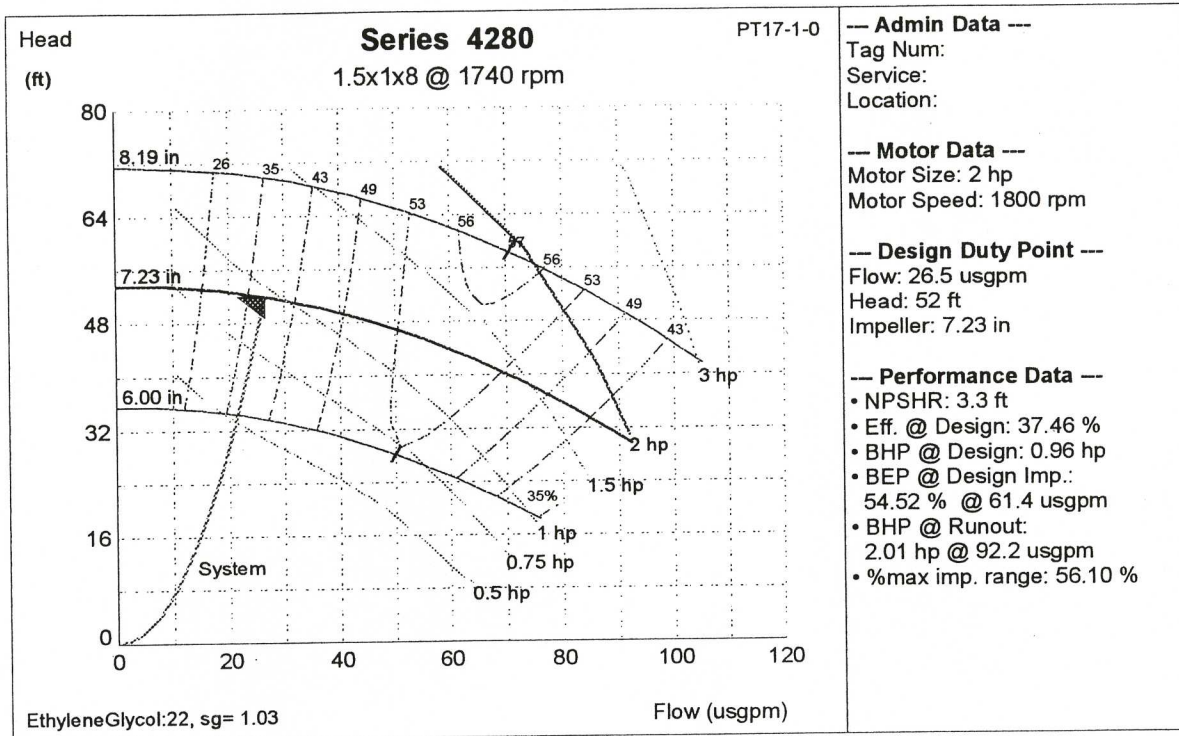

PACKAGED AIR COOLED Product Data Catalog

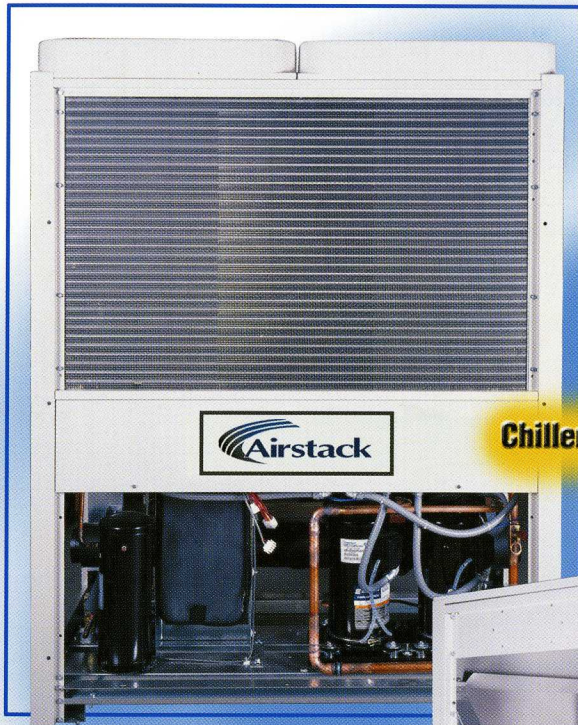

Chiller Module



Free Cool Module

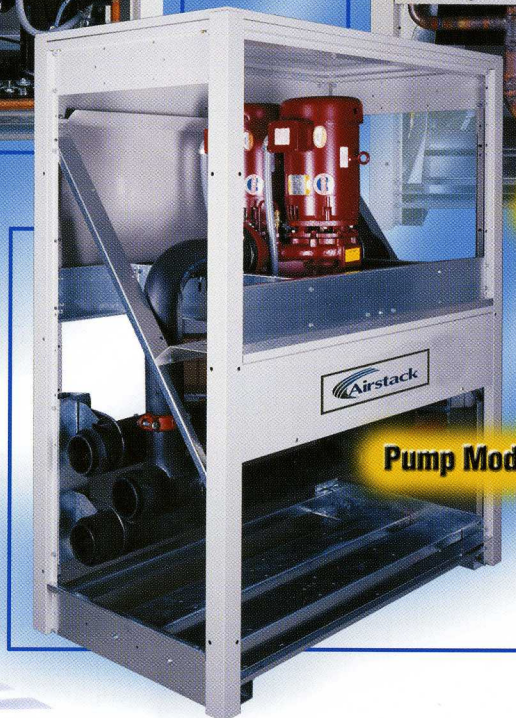

Pump Module

MODELS
ASP-10A
ASP-15A
ASP-20A
ASP-00P
ASP-00F
ASP-00G

Airstack®



The Leader in Modular Chillers

AIRSTACK PACKAGED AIR COOLED CHILLER MODULES

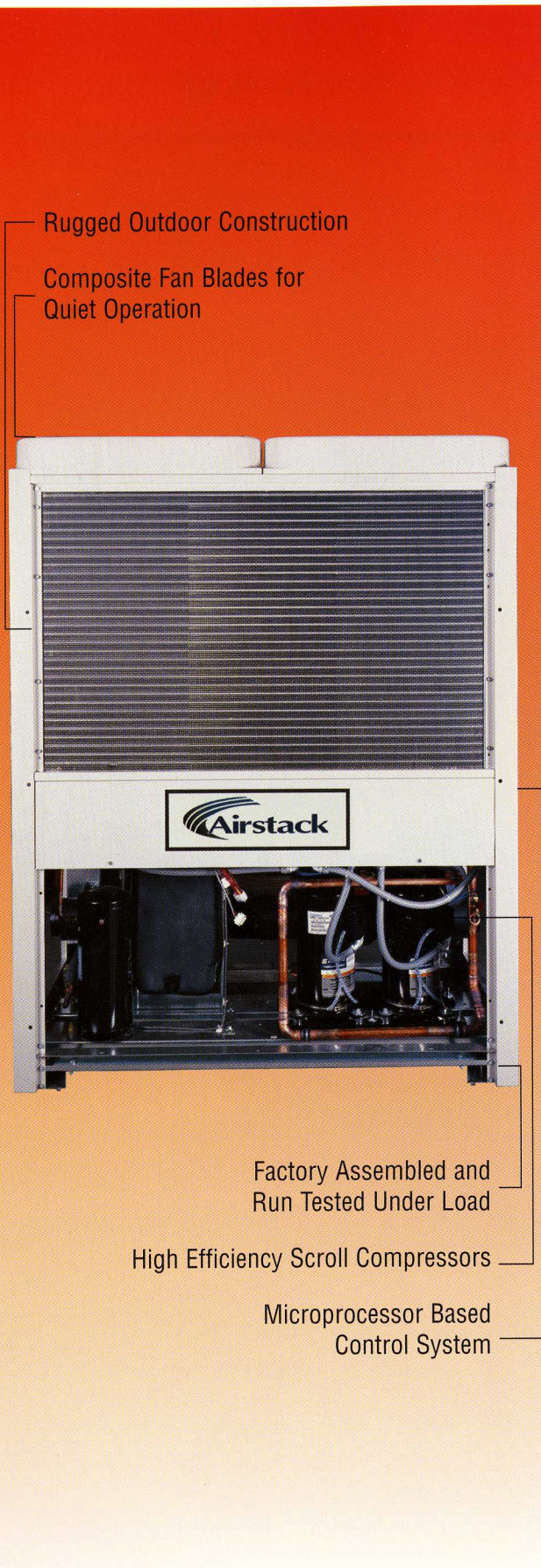

AIRSTACK AIR COOLED MODULAR PACKAGED WATER CHILLER

Highly Dependable

- Multiple independent refrigeration circuits
- Comprehensive computer monitoring of operations
- Automatic diagnostic recording of fault conditions
- Automatic rotation of lead compressors

Simple To Operate

- LCD Screen displays information in plain English
- Simple keypad provides control of system operations

Easy To Install

- Compact modules fit through standard doorways and into elevators
- Modules interconnect easily and quickly to form chillers from 10 to 200-tons
- All refrigeration systems are factory charged and run tested

Computer Control System

- Operates only the capacity required by the load
- Operates at peak efficiency at any given load

Design Flexibility

- Wide array of module combinations
- Install only the capacity required at the time

Simple To Service

- Does not require proprietary training
- Service can often be performed on a convenient non-emergency basis
- Most components are standard, off the shelf design

AIRSTACK PACKAGED AIR COOLED

PERFORMANCE DATA

**ASP-10A Air Cooled Modular Chiller
Single Module Performance Data**

AMBIENT AIR TEMPERATURE °F <i>(A suitable antifreeze solution is required for operation below 40°F Ambient)</i>									
	85.0			95.0			105.0		
	Tons	KW	EER	Tons	KW	EER	Tons	KW	EER
40.0	9.4	9.8	11.5	8.8	10.9	9.7	8.3	12.2	8.1
42.0	9.8	9.8	12.0	9.2	10.9	10.2	8.6	12.2	8.5
44.0	10.2	9.8	12.5	9.6	10.9	10.6	9.0	12.2	8.9
45.0	10.4	9.8	12.8	9.8	10.9	10.8	9.2	12.2	9.1
46.0	10.6	9.8	13.0	10.0	10.9	11.0	9.4	12.2	9.2
48.0	11.0	9.8	13.5	10.4	10.9	11.5	9.8	12.2	9.6
50.0	11.5	9.8	14.1	10.8	10.9	12.0	10.2	12.1	10.1

**ASP-15A Air Cooled Modular Chiller
Single Module Performance Data**

AMBIENT AIR TEMPERATURE °F <i>(A suitable antifreeze solution is required for operation below 40°F Ambient)</i>									
	85.0			95.0			105.0		
	Tons	KW	EER	Tons	KW	EER	Tons	KW	EER
40.0	13.9	14.1	11.8	13.0	15.8	9.9	12.1	17.7	8.2
42.0	14.5	14.1	12.3	13.6	15.8	10.3	12.7	17.7	8.6
44.0	15.0	14.1	12.8	14.2	15.8	10.8	13.2	17.7	9.0
45.0	15.3	14.1	13.0	14.4	15.8	11.0	13.5	17.7	9.1
46.0	15.6	14.1	13.3	14.7	15.8	11.2	13.8	17.7	9.3
48.0	16.2	14.2	13.8	15.3	15.8	11.6	14.3	17.7	9.7
50.0	16.9	14.2	14.3	15.9	15.8	12.1	14.9	17.7	10.1

**ASP-20A Air Cooled Modular Chiller
Single Module Performance Data**

AMBIENT AIR TEMPERATURE °F <i>(A suitable antifreeze solution is required for operation below 40°F Ambient)</i>									
	85.0			95.0			105.0		
	Tons	KW	EER	Tons	KW	EER	Tons	KW	EER
40.0	19.4	18.5	12.6	18.3	20.7	10.6	17.2	23.1	8.9
42.0	20.2	18.5	13.1	19.1	20.7	11.1	17.9	23.2	9.3
44.0	21.0	18.5	13.6	19.9	20.7	11.5	18.7	23.2	9.7
45.0	21.4	18.5	13.9	20.3	20.7	11.7	19.0	23.2	9.8
46.0	21.8	18.5	14.1	20.7	20.7	12.0	19.4	23.2	10.0
48.0	22.7	18.6	14.7	21.5	20.7	12.4	20.2	23.2	10.4
50.0	23.6	18.6	15.2	22.3	20.8	12.9	21.0	23.2	10.9

NOTES:

1. Capacity is based on pure water. For performance using Glycol Solution, see Adjustment Factor on Page 6.
2. All performance data is based on a 10°F chilled water temperature drop through the evaporator.
3. Fan and controls KW is included in tabular KW data.

AIRSTACK PACKAGED AIR COOLED

PERFORMANCE

**ASP-00F Free Cooling Module
Single Module Performance Data**

Capacity in Refrigeration Tons

Ambient	LEAVING WATER TEMPERATURE/GPM								
	45°F			50°F			55°F		
	30 GPM	60 GPM	90 GPM	30 GPM	60 GPM	90 GPM	30 GPM	60 GPM	90 GPM
40°F	5.1	4.7	4.5	10.4	9.4	8.9	16.0	14.1	13.4
35°F	10.2	9.3	8.9	15.8	14.1	13.3	21.5	18.8	17.8
30°F	15.5	14.0	13.3	21.2	18.7	17.8	27.0	23.5	22.3

NOTES:

1. Capacity is based on pure water. For performance using Glycol Solution, see Adjustment Factor on Page 6.
2. A suitable antifreeze solution is required for operation below 40°F Ambient.

General Data Table of Air Cooled Standard Modules

Compressor	ASP - 00F	ASP - 10A	ASP - 15A	ASP - 20A
Type	n/a	Scroll	Scroll	Scroll
Weight (lb. each)	n/a	104	119	141
Nominal Capacity (per compressor)	n/a	5	7.5	10
Quantity	n/a	2 (tandem pair)	2 (tandem pair)	2 (tandem pair)
Oil Charge (pints per compressor)	n/a	3.6	5.25	7
Evaporator				
Type	n/a	Brazed Plate	Brazed Plate	Brazed Plate
Weight	n/a	61.2	78.3	90.3
Evap Water Storage (gallons each)	n/a	1.5	1.85	2.2
Quantity	n/a	1	1	1
Header Storage (gallons per header)	3.3	3.3	3.3	3.3
Refrigerant Type	n/a	R-22	R-22	R-22
Number of Circuits	1	1	1	1
Condenser Fans				
Motor Type	Totally Enclosed	Totally Enclosed	Totally Enclosed	Totally Enclosed
HP	1	1	1	1
Quantity	2	2	2	2
Fan Type	axial	axial	axial	axial
Fan Material	composite	composite	composite	composite
Air Flow (cfm) (per module)	8,500	6,600	6,600	8,500
Condenser Coils*				
Fin Material	aluminum	aluminum	aluminum	aluminum
Tube Material	copper	copper	copper	copper
Tube Diameter (in.)	1/2	3/8	3/8	3/8
Number of Rows	6	4	4	6
Coil Dimensions/Quantity	30 x 49/2	32 x 51/2	32 x 51/2	30 x 49/2
Receiver Capacity (lb.)	n/a	17.4	17.4	17.4
Module Dry Weight (lb.)	1,150	1,350	1,370	1,411

*On Free Cool Modules, coils are utilized as water precoolers rather than for refrigerant condensing.

AIRSTACK PACKAGED AIR COOLED

PUMP DATA

ASP-OOP DUAL PUMP SELECTION CHART

(ALL PUMPS IN PRIMARY/STANDBY ARRANGEMENT – DATA FOR SINGLE PUMP)

Charts Show Pump BHP Requirement at Given Condition

ARMSTRONG SERIES 4382 – 3x3x6 Pump					
TOTAL HEAD IN FEET					
Flow (USGPM)	60	80	100	120	140
40		3.07	3.87	4.66	5.47
80		3.58	4.47	5.37	6.29
120	3.55	4.52	5.51	6.50	7.51
160	4.82	5.91	7.00	8.09	9.20
200	6.71	7.94	9.13	10.34	
240		10.97	12.27		

ARMSTRONG SERIES 4382 – 4x4x6 Pump					
TOTAL HEAD IN FEET					
Flow (USGPM)	60	80	100	120	140
50		3.80	4.89	6.10	7.44
100		4.52	5.77	7.12	8.57
150	3.98	5.30	6.70	8.16	9.71
200	4.78	6.26	7.79	9.39	
250	5.81	7.54	9.14	10.90	
300	7.16	9.03	10.91		
350	8.90	11.07			

ARMSTRONG SERIES 4382 – 6x6x6 Pump					
TOTAL HEAD IN FEET					
Flow (USGPM)	60	80	100	120	140
200		7.86	10.24	12.78	15.47
300		9.75	12.39	15.15	
400	8.99	11.82	14.73	17.72	
500*	10.93*	14.14*	17.34*	20.59*	
600*	13.06*	16.68*	20.26*		
700*	15.48*	19.51*			
800*	18.35*	22.76*			

* For selections above 400 GPM contact factory

NOTES:

1. DO NOT SELECT IN SHADED AREA.
2. All selections based on 40% Ethylene Glycol Solution.
3. Pump speed is 3600 RPM.
4. All pump modules have automatic changeover controls in the event of loss of flow and manual lead/lag selector switch.

**AIRSTACK PACKAGED AIR COOLED
CAPACITY TABLES**

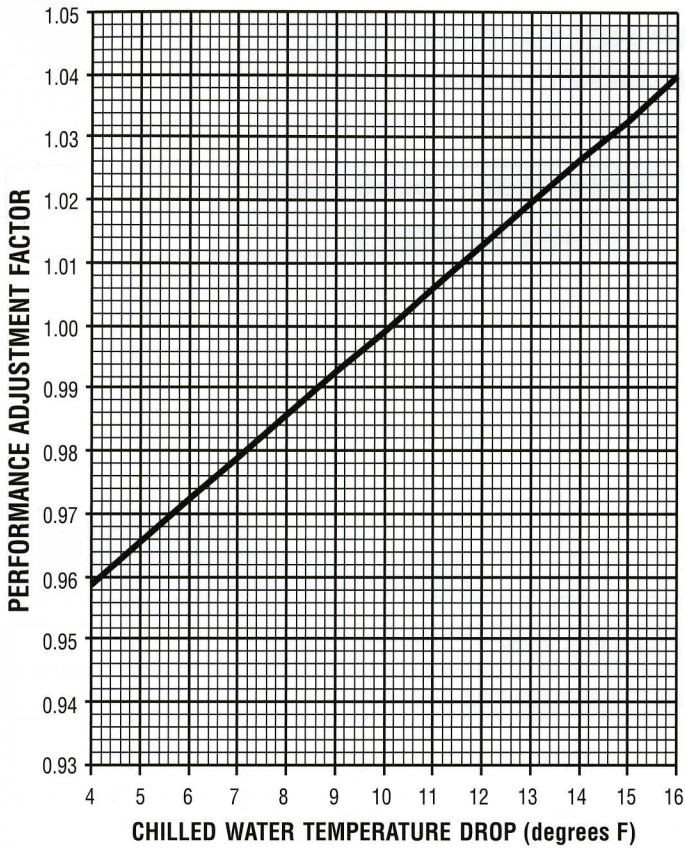

Figure 1. Performance Adjustment Factor

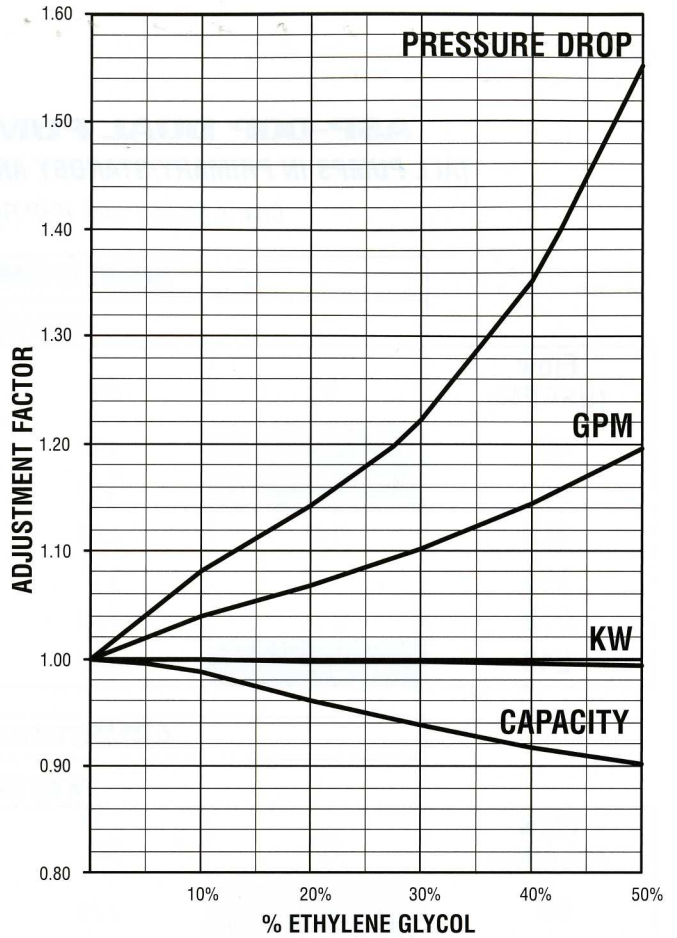

Figure 3. Ethylene Glycol Adjustment Factors

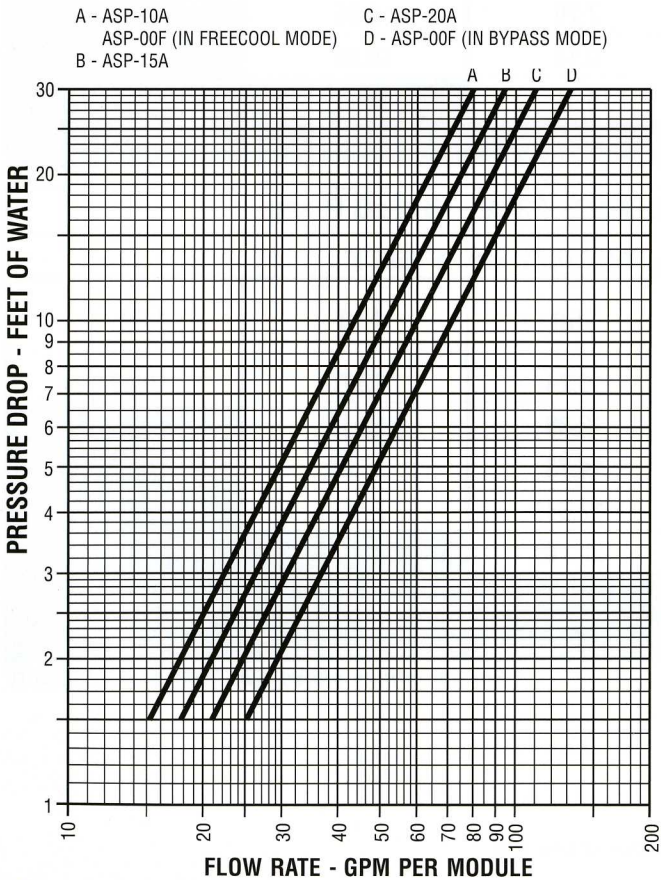

Figure 2. Water Pressure Drop

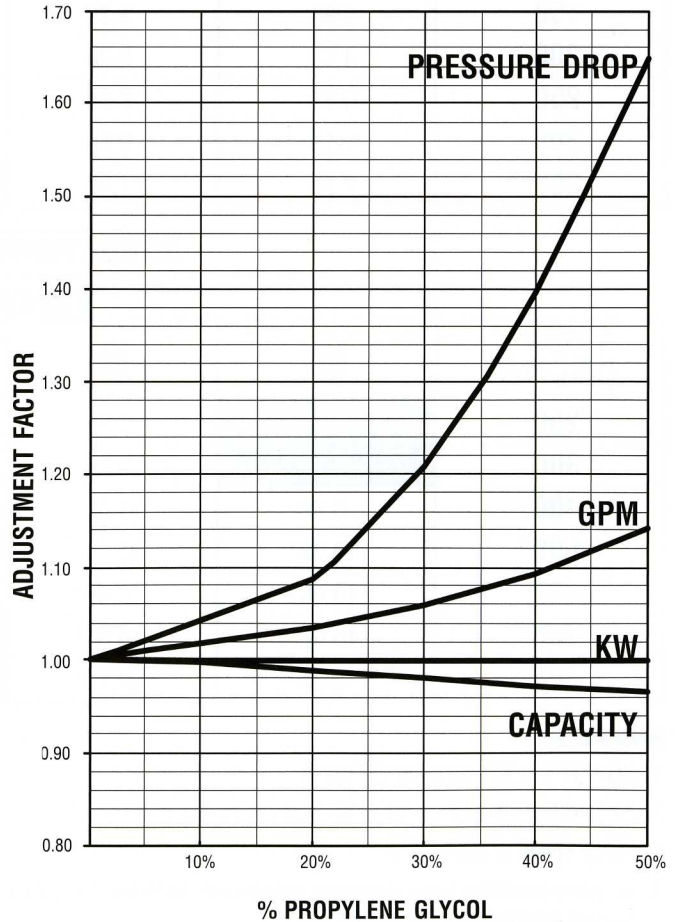

Figure 4. Propylene Glycol Adjustment Factors

SELECTION

To select an AIRSTACK Air Cooled chiller, the following information is required.

1. Load in tons of refrigeration.
2. Chilled water temperature drop.
3. Leaving chilled water temperature.
4. Design ambient air temperature.

CAPACITY TABLES

Capacity tables are based on a 10°F temperature drop through the evaporator. For other than 10°F temperature drop, apply the respective performance adjustment factors from **Figure 1**.

EVAPORATOR WATER FLOW RATE

Evaporator water flow is determined as follows:

$$\text{GPM} = (24) (\text{tons}) / \text{temperature drop}$$

WATERSIDE PRESSURE DROP

Evaporator waterside pressure drops are provided in **Figure 2**. To use **Figure 2**, divide the total chilled water GPM by the number of modules in the chiller.

CHILLED WATER SELECTION SAMPLE (Assumes ASP-15 Modules)

System load = 55 tons. Chilled water drop at 12°F. Leaving chilled water temperature of 45°F. Design ambient air temp of 95°F.

1. Use **Figure 1** adjustment factor to convert tons at 12°F to equivalent tons at 10°F for use with capacity tables. Tons = $55/1.012 = 54.3$ tons
2. Select the appropriate performance table based on module to be used. Read the capacity and KW of a single module at the water temperature specified (45°F) and design ambient air temperature (95°F) capacity = 14.4 tons, KW = 15.8
3. Divide equivalent tons required at 10°F temperature drop by single module capacity from tables.
 Modules required = $54.3/14.4 = 3.8$ modules
 Chiller capacity = $14.4 \times 4 = 57.6$ tons
 Power input = $15.8 \times 4 = 63.2$ KW at 12°F temperature drop, applying **Figure 1** performance adjustment factor results in:
 Tons = $(57.6) (1.012) = 58.3$ vs. system load of 55 tons
4. To determine evaporator water flow and pressure drop, first determine GPM.
 GPM = $(24)(54.3)/12=108.6$
 GPM/module = $108.6 = 27.2$
 From **Figure 2**, read pressure drop from curve C pressure drop = 2.4 ft. of water.

LOW TEMPERATURE OPERATION WITH GLYCOL (Assumes ASP-15 Modules)

Ethylene Glycol adjustment factors (**Figure 3**) should be used to adjust performance depending on the percent of glycol use in the evaporator circuit. The factors in **Figure 3** are based on a 10°F change in fluid temperature through the evaporators.

Capacity and KW should be obtained by extrapolating no more than 10°F from the lowest leaving chilled water temperature shown in the capacity tables.

AIRSTACK should be contacted if leaving Glycol temperatures below 32°F are required.

Adjustment factors for Propylene Glycol are shown in **Figure 4**, and are used in the same way given in the following example.

ETHYLENE GLYCOL SELECTION EXAMPLE (Assumes ASP-15 Modules)

Determine capacity, GPM, pressure drop and KW for a ASP-15 module cooling 30% Ethylene Glycol from 45°F to 35°F, with design ambient air temperature of 95°F.

1. By extrapolating from the performance tables:
 capacity: 11.5 tons; 15.8 KW;
2. Evaporator water flow and pressure drop is determined for water as in the previous example.

$$\text{GPM} = \frac{(24) (11.5)}{10} = 27.6 \text{ GPM}$$

From **Figure 2** read pressure drop from curve C pressure drop = 2.6 ft of water

3. To convert performance for water to performance with Ethylene Glycol read adjustment factors from **Figure 3** at 30% Glycol.

Capacity adjustment:	0.94
KW adjustment:	0.99
GPM adjustment:	1.10
Pressure drop adjustment	1.22

4. Calculate performance with 30% Ethylene Glycol by multiplying performance for water by adjustment factors.

Capacity:	$11.5 \times .94 = 10.8$ tons
KW:	$15.8 \times .99 = 15.6$ KW
GPM:	$27.6 \times 1.10 = 30.4$ GPM
Pressure drop:	$2.6 \times 1.22 = 3.2$ ft. of water

If a water temperature drop greater or less than 10°F is required, begin by first multiplying the capacity using the performance adjustment factor from **Figure 1**.

AIRSTACK PACKAGED AIR COOLED CONFIGURATIONS

IMPORTANT MODULE CONFIGURATION INFORMATION

ASP-00P PUMP MODULE:

1. When present, a Pump Module is only allowed in the "Front" position.
2. Incoming water to the chiller system must enter at the Pump Module.
3. Leaving water from the chiller system may be from either end of the chiller.
4. An ASP-10A, 15A, 20A Chiller Module may not be attached in the rear module position of a Pump Module.

ASP-00F FREE COOL MODULE:

1. When present, incoming system water must enter through the Free Cool Modules prior to entering an ASP-10A, 15A, 20A Chiller Module.
2. You may not attach a Rear Free Cool Module to a Front ASP-10A, 15A, 20A Chiller Module.
3. You may not attach a Rear ASP-10A, 15A, 20A, Chiller Module to a Front Free Cool Module.
4. Only a Free Cool Module may be attached to the rear of a Pump Module.

ASP-00G GLYCOL FEEDER MODULE:

1. An ASP-00G Glycol Feeder Module may be attached in any rear position.

ASP-10A, 15A, 20A CHILLER MODULE:

1. Maximum number of ASP-10A, 15A, 20A modules with a single Master Module is **10** (i.e., (1) Front-Master, (4) Front-Slaves, and (5) Rear-Slaves).
2. You may have more than one Master Module in a single Chiller Bank.
3. Piping sides of an ASP-10A, 15A, 20A, Chiller without Free Cool or Pump Modules attached are field selectable.

**FRONT OF CHILLER BANK IS TOWARD
THE BOTTOM OF THE PAGE**
(Master Module location determines front of chiller)

VALID CONFIGURATIONS

SR	SR	SR	SR	GR
MF	SF	SF	SF	SF

	SR	SR
PF	MF	SF

FR		SR	SR	
PF	FF	MF	SF	SF

SR	GR	SR	SR	SR	
MF	SF	SF	MF	SF	SF

INVALID CONFIGURATIONS

SR	SR	SR	SR	SR	SR
MF	SF	SF	SF	SF	

Problem: Too many Slaves on one Master.
Solution: Add an additional Master in place of one of the Slaves.

SR	SR	SR
PF	MF	SF

Problem: Slave cannot be attached to rear of Pump Module.
Solution: Move Slave to front position on opposite end of chiller.

	SR	SR
MF	PF	SF

Problem: Pump Module must be on entering waterside of chiller.
Solution: Swap position of Pump with Master Module.

FR	SR	SR	SR
PF	FF	MF	SF

Problem: Slave module is attached to the rear of a Free Cool Module.
Solution: Move this Slave to the right of the last Front Slave.

SR	SR	SR
PF	MF	GF

Problem: Glycol Feeder Module is attached in a front position.
Solution: Move Glycol Feeder Module to rear position and exchange Slave Rear Module for Slave Front Module.

For other configurations contact your local Airstack Representative.

LEGEND: FIRST LETTER

- M** = Master Chiller Module (ASP-10A, 15A, 20A)
- S** = Slave Chiller Module (ASP-10A, 15A, 20A)
- P** = Pump Module (ASP-00P)
- F** = Free Cool Module (ASP-00F)
- G** = Glycol Feeder Module (ASP-00G)

SECOND LETTER

- F** = Front Module
- R** = Rear Module

AIRSTACK PACKAGED AIR COOLED

MODULES

SINGLE MODULE

- NOTES:**
1. ALL MODULES HAVE SAME DIMENSIONS.
 2. NO OBSTRUCTIONS ALLOWED ABOVE CONDENSER FANS.
 3. REQUIRED SERVICE CLEARANCE AT MODULE ENDS: 36".
 4. REQUIRED AIR INTAKE CLEARANCE: 42".
 5. REQUIRED CLEARANCE FROM ANY HIGH VOLTAGE PANEL: 42".

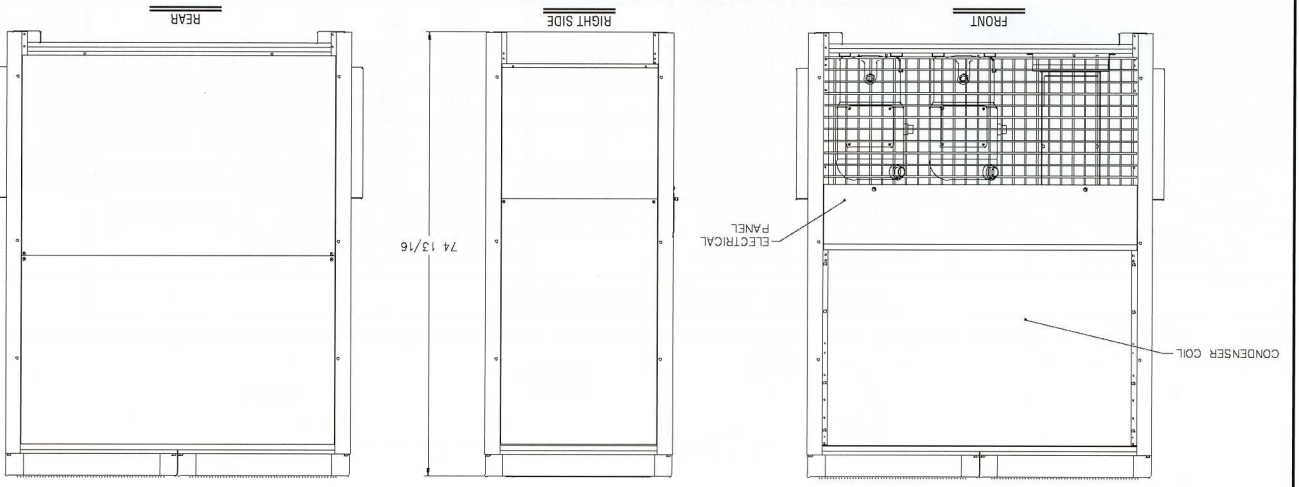

MULTIPLE MODULES

- NOTES:**
1. MODULES ARE BOLTED TOGETHER IN FIELD.
 2. HARDWARE QUANTITIES ARE SPECIFIC TO EACH CHILLER (NO. OF MODULES).
 3. ALL MODULES HAVE SAME DIMENSIONS.
 4. NO OBSTRUCTIONS ALLOWED ABOVE CONDENSER FANS.
 5. REQUIRED SERVICE CLEARANCE AT MODULE ENDS: 36".
 6. REQUIRED AIR INTAKE CLEARANCE: 42".
 7. REQUIRED CLEARANCE FROM ANY HIGH VOLTAGE PANEL: 42".

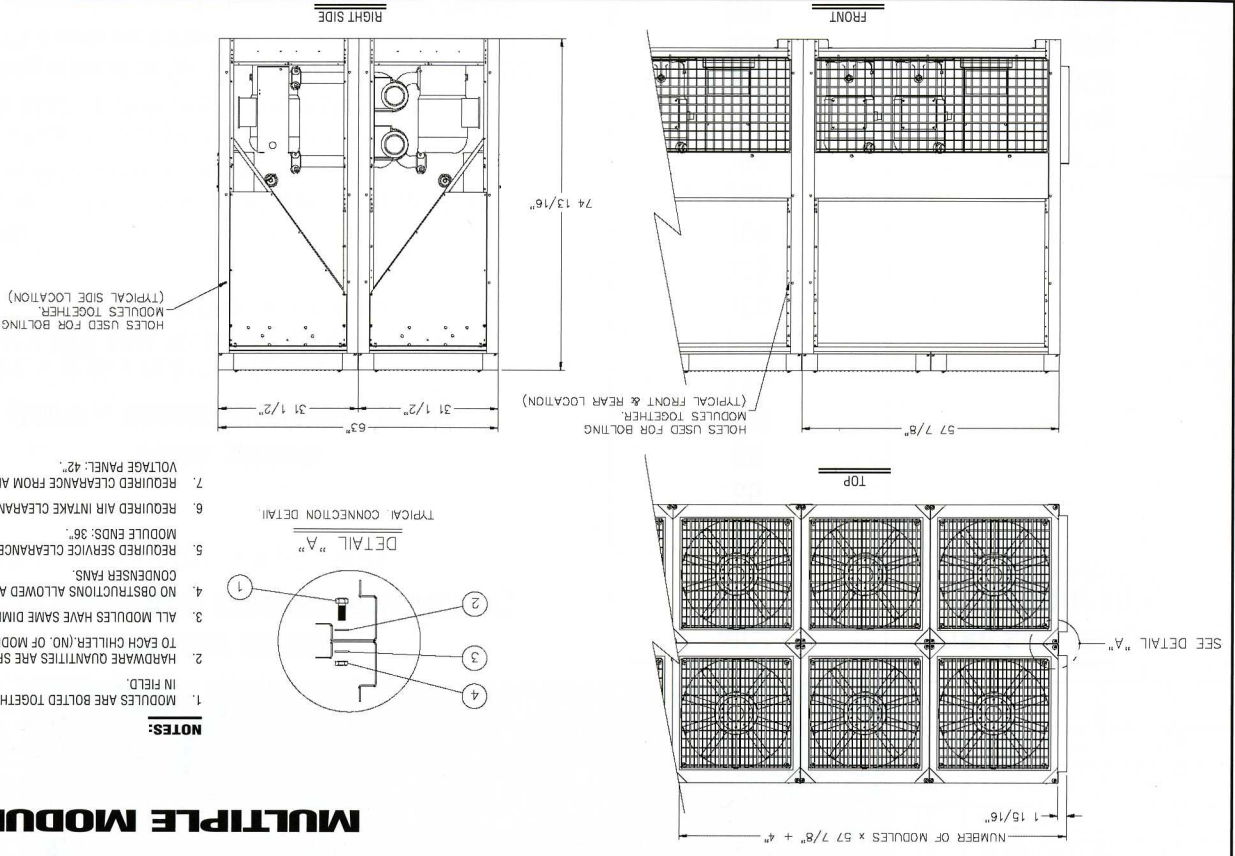
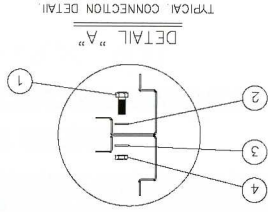

**AIRSTACK PACKAGED AIR COOLED
PERFORMANCE**

**REQUIRED CHILLED WATER PIPING
SUPPLIED AND INSTALLED BY OTHERS**

(* If ASP-00P Pump Module is Supplied by Airstack, eliminate external Pump shown below.)

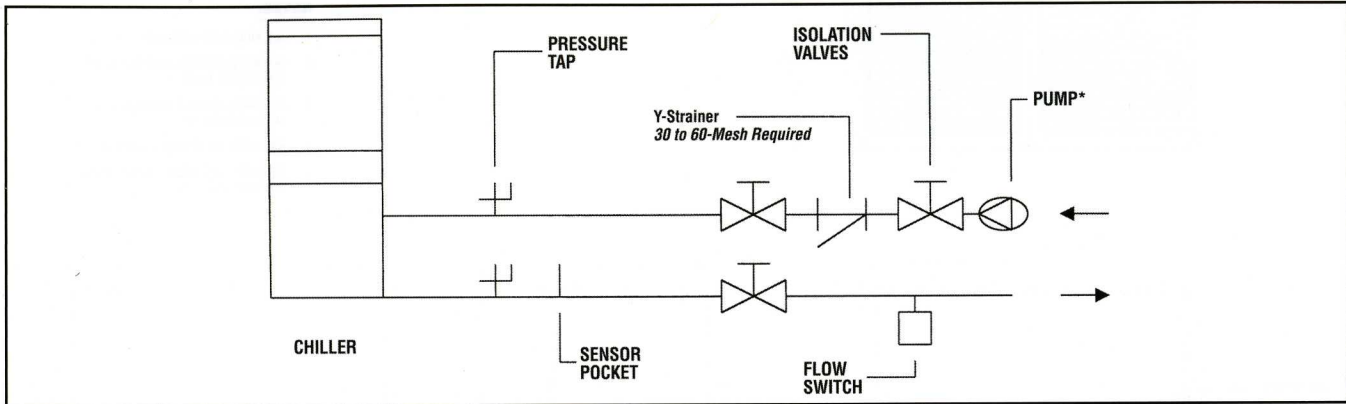

ELECTRICAL DATA

Model	Number of Compressors	RLA per Compressor		Number of Fan Motors	FLA per Fan Motor		Pump HP	Max Pump FLA	
		3 phase	1 phase		3 phase	1 phase		3 phase	1 phase
		208/460/575V	230V		208/460/575V	230V		208/460/575V	230V
ASP - 10A	2 (tandem pair)	16.5/7.7/6.2	25.4	2	4.2/2.0/1.5	5			
ASP - 15A	2 (tandem pair)	24.6/11.7/9.4	n/a	2	4.2/2.0/1.5	n/a			
ASP - 20A	2 (tandem pair)	34.0/15.8/12.7	n/a	2	4.2/2.0/1.5	n/a			
ASP - 00F	n/a	n/a	n/a	2	4.2/2.0/1.5	n/a			
ASP - 00P							5	16.7/7.6/6.1	30.8
ASP - 00P							7.5	24.2/11/9	n/a
ASP - 00P							10	30.8/14/11	n/a
ASP - 00P							15	46.2/21/17	n/a
ASP - 00P							20	59.4/27/22	n/a
ASP - 00P							25	74.8/34/27	n/a
ASP - 00G							n/a	2/1/1	2

WIRING SIZING

(MCA= MINIMUM CIRCUIT AMPACITY)

$$MCA = (1.25 \times RLA1^*) + RLA2 + RLA3 \dots$$

FUSE SIZING

(MFS = MAXIMUM FUSE SIZE)

$$MFS = (2.25 \times RLA1^*) + RLA2 + RLA3 \dots$$

Where MFS does not equal a standard size fuse, the next larger fuse should be used.

NOTES:

- Compressor Rated Load Amps (RLA) are based on 125°F Saturated Condensing Temperature.
- *RLA1 = RLA of the largest motor in the system. RLA2 & RLA3 = RLA of other motors in the system.
- Wire sizing is based on Nat. Electr. Code (NEC) rating for 75°C wire, with 3 wires per conduit.
- Wiring distance from branch circuit shall not exceed 100 feet.

MCA	WIRE SIZE (AWG) 75° 3 CONDUCTORS 1 Conduit
50	8
65	6
85	4
100	3
115	2
130	1
150	1/0
175	2/0
200	3/0
230	4/0
255	250 MCM
285	300 MCM
310	350 MCM
335	400 MCM
380	500 MCM

AIRSTACK PACKAGED AIR COOLED

MECHANICAL SPECIFICATIONS

GENERAL

Chiller Modules shall be ETL listed in accordance with UL Standard 1995, CSA certified per Standard C22.2#236, and bear the ASME UM stamp on all water-to-refrigerant heat exchangers.

Modules shall ship wired and charged with refrigerant. All modules shall be factory run tested prior to shipment.

Compressors, heat exchangers, condenser fans, piping and controls shall be mounted on a heavy gauge steel frame. Electrical controls, contractors, and relays for each module shall be mounted within that module. Module shall be provided within a steel enclosure suitable for outdoor use. Exposed steel surfaces shall be provided with a powder coat paint finish.

CHILLED WATER MAINS

Each module shall include supply and return mains for chilled water. Grooved end connections are provided for interconnection to four inch standard (4.5" outside diameter) piping with Victaulic type couplings. Each inlet water header shall incorporate a built in 30-mesh in-line strainer system to prevent heat exchanger fouling.

EVAPORATORS

Each evaporator shall be a brazed plate heat exchanger constructed of 316 stainless steel; designed, tested, and stamped in accordance with ASME code for 360 psig water-side working pressure.

COMPRESSOR

Each module shall contain hermetic scroll compressor(s) mounted to the module with rubber-in-shear isolators. Each system shall also include high discharge pressure and low suction pressure safety cut-outs.

CONDENSER COILS

Air cooled condenser coils shall have aluminum fins mechanically bonded to copper tubing. Condensers shall have integral subcooling circuitry and be factory leak tested.

CONDENSER FANS

Each module shall contain dual condenser fans for each refrigerant circuit. These fans shall be multi-blade vane-axial type made of plastic composite material for quiet operation. Fans shall be direct driven at maximum RPM of 1150. All fan motors shall be pressure controlled and suitable for outdoor use.

CENTRAL CONTROL SYSTEM

Scheduling of the various compressors shall be performed by a microprocessor based control system

(Master Controller). A new lead compressor is selected every 24 hours to assure even distribution of compressor run time.

The Master Controller shall monitor and report the following on each refrigeration system:

- Discharge Pressure Fault
 - Suction Pressure Fault
 - Compressor Winding Temperature Fault
 - Suction Temperature
 - Evaporator Leaving Chilled Water Temperature

The Master Controller shall monitor and report the following system parameters:

- Chilled Water Entering and Leaving Temperature
 - Discharge Refrigerant Temperature
 - Chilled Water Flow Fault

An out-of-tolerance indication from these controls or sensors shall cause a "fault" indication at the Master Controller and shutdown of that compressor with the transfer of load requirements to the next available compressor. In the case of a System Fault the entire chiller will be shut down. When a fault occurs, the Master Controller shall record conditions at the time of the fault and store the data for recall. This information shall be capable of being recalled through the keypad of the Master Controller and displayed on the Master Controller's LCD. A history of faults shall be maintained including date and time of day of each fault (up to the last 20 occurrences).

Individual monitoring of leaving chilled water temperatures from each refrigeration system shall be programmed to protect against freeze-up.

The control system shall monitor entering and leaving chilled water temperatures to determine system load and select the number of compressor circuits required to operate. Response times and set points shall be adjustable.

LOW AMBIENT OPERATION

Each refrigerant circuit shall include all refrigerant specialties to provide reliable operation down to 0°F Ambient.

OPTIONAL LOW AMBIENT TO -20°F

Chiller shall incorporate appropriate refrigerant specialties including a properly sized refrigerant receiver and flooded head pressure control valves for operation to -20°F.

**AIRSTACK PACKAGED AIR COOLED
MECHANICAL SPECIFICATIONS**

**OPTIONAL SINGLE POINT
POWER CONNECTION**

Chiller shall be provided with a single point power connection. This will include pre-engineered wiring for field installation and connection to a factory mounted chiller junction box. Junction box shall include individual fusing for each Module Set and provide a single point of connection to building power.

**OPTIONAL FREE
COOLING MODULE**

Free Cooling Modules shall interconnect through the common chiller header system and require no additional water connections. Free Cooling Modules shall include glycol cooling coils, temperature controlled fans and an automatic 3-way bypass valve to eliminate the need for mechanical cooling under low ambient conditions. Module shall be completely factory assembled and tested before shipment.

OPTIONAL PUMP MODULE

The Pump Module shall be interconnected through the common chiller header system and require no additional water connections. Pump Module will become an integral part of the chiller system. Pump Module shall incorporate dual in-line centrifugal pumps in a Primary/Standby pumping arrangement. Pump starters and controls shall be provided to enable manual selection of lead pump. In addition, in the event of a loss-of-flow failure of the chilled water system, the Pump Module controls shall disable the lead pump and automatically start the standby pump. Module shall be completely factory assembled and tested prior to shipment.

**OPTIONAL GLYCOL
FEEDER MODULE**

Optional Glycol Feeder and Expansion Tank shall be incorporated into the chiller system through a modular arrangement and interconnect through the common chiller header system requiring no additional water connections. System shall include a 48 gallon storage/mixing tank with lid and cover; pump suction hose with inlet strainer; pressure pump with thermal cut-out, and integral pressure switch; pre-charged accumulator tank with EPDM diaphragm, manual diverter valve for purging and agitating contents of storage tank, adjustable 5-55 psi pressure regulating valve with pressure gauge, fast fill lever, integral replaceable strainer, built in check valve, and built in shut-off valve. Glycol feeder system shall be compatible with glycol solutions of up to 50% concentration. Pump shall be capable of running dry without damage.

Expansion tank shall be welded steel with butyl rubber diaphragm and capable of a maximum operating temperature of 240°F and maximum working pressure of 100 psig. Tank shall be interconnected through the common chiller header system and require no additional water connections. Module shall be completely factory assembled and tested prior to shipment.



1065 Maple Avenue
PO Box 510
Sparta, WI 54656
Phone 608-366-2400
Fax 608-366-2450
www.airstack.com

MANUFACTURED BY MULTISTACK
The Leader in Modular Chillers

ACPDATA071501
020105

Airstack®

Air Cooled Packaged Chiller

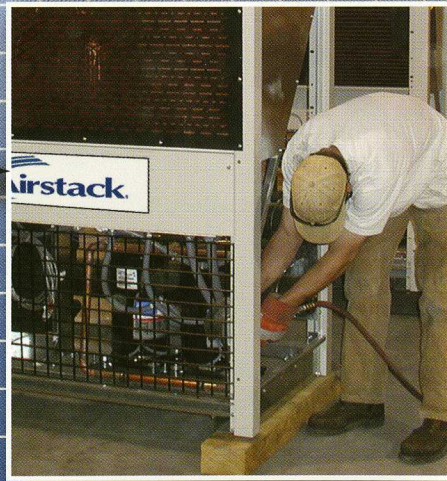
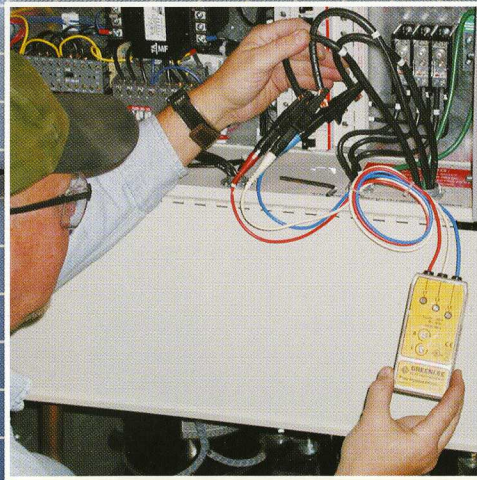
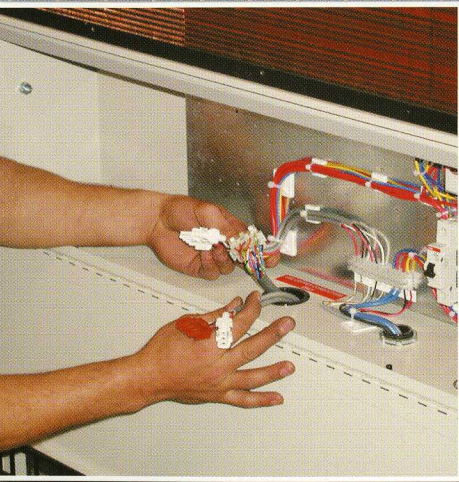
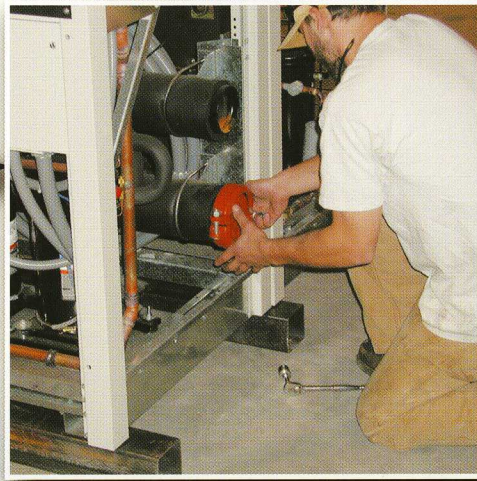

Installation Manual
Air Cooled Chiller



Introduction

The AIRSTACK "ASP" is a modular air-cooled chiller system with a nominal capacity of 10, 15 and 20 tons per module. The chiller system consists of a Master module (front module with controller), front and rear modules, free cooling module and a pump module. This system utilizes a fully hermetic scroll compressor, 316 stainless steel brazed plate heat exchanger, 4 or 6 row copper tube, aluminum fin, condenser coils and a microprocessor-based control. Operating capacity is based on the entering chilled liquid temperature. Precise control and system reliability is best served in this fashion.

This manual was created for the express purpose of assisting the owner or installing contractor of the AIRSTACK Packaged Air Cooled Product "ASP".

Please review the material contained in this document carefully before installing and operating this equipment. Additional inquiries regarding installation and operation should be directed to AIRSTACK or its authorized agents. Failure to handle, install and operate this equipment in accordance with this manual may result in damage to the equipment and/or personal injury. Failure to comply may void some or all of the AIRSTACK warranty options.

Any questions regarding the content of this Installation Manual, the handling or installation of the AIRSTACK Chiller components should be directed immediately to your authorized representative or to the **Service Department** at **(608) 786-3400** or **FAX (608) 786-3450**.

Equipment Description



AIRSTACK "ASP"

The chiller will consist of **Modules** (one master, fronts, and backs), with an optional **Free Cooling Module** (no compressors), and an optional **Water Pump Module**.



Master Module

The **Master Module** for each chiller is designated at the factory. This module includes the **Microprocessor Display**.



Front Module

Front Modules contain the 4" water header distribution pipes and has a slave control board. This module will bolt together with the **Rear Module**.



Rear Module

This module will be attached to the **Front Module** by vertical frame bolts and the evaporator is connected by cross over pipes to the **Front Modules** water header pipes. It also has its own slave board.



Free Cooling Modules

This module has fin and tube coils for free cooling operation and no mechanical refrigeration (no compressors). The module contains a 3-way diverting valve for either enabling free cooling or by-pass for mechanical cooling.

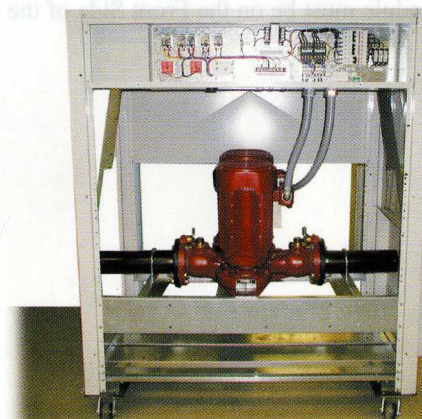

Pump Package Module

This module contains a centrifugal dual-arm pump and water distribution headers. This module is for installations where no pump is provided for the chilled water system or when additional pumping capacity is required.

Important Module Configurations

ASP-00P Pump Module

1. When present, a Pump Module is only allowed in the "Front" position.
2. Incoming water to the chiller system must enter at the Pump Module.
3. Leaving chilled water may be from either end of the chiller.
4. An ASP-10A, 15A, or 20A Chiller Module may not be attached in the rear module position of a Pump Module.

ASP-00F Free Cool Module

1. When present, incoming system water must enter through the Free Cool Modules prior to entering an ASP-10A, 15A, or 20A Chiller Module.
2. You may **NOT** attach a Rear ASP-10A, 15A, or 20A Chiller Module to a Chiller Module.
3. You may **NOT** attach a Rear ASP-10A, 15A, or 20A Chiller Module to a Front Free Cool Module.
4. Only a Free Cool Module may be attached to the rear of a Pump Module.

ASP-00G Glycol Feeder Module

1. An ASP-00G Glycol Feeder Module may be attached in any rear position.

ASP-10A, 15A, or 20A Chiller Module

1. Maximum number of ASP-10A, 15A, or 20A modules with a single Master Module is 10 (i.e. (1) Front Master, (4) Front-Slaves, and (5) Rear-Slaves).
2. You may have more than one Master Module in a single Chiller Bank.
3. Piping sides of an ASP-10A, 15A, or 20A Chiller without Free Cool or Pump Modules attached are field selectable.
4. Master Module must be on the Front Side of the Chiller.

Valid Configurations

SR	SR	SR	SR	GR
MF	SF	SF	SF	SF

	SR	SR
PF	MF	SF

FR		SR	SR	
PF	FF	MF	SF	SF

SR	GR	SR	SR	SR	
MF	SF	SF	MF	SF	SF

Invalid Configurations

SR	SR	SR	SR	SR	SR
MF	SF	SF	SF	SF	

Problem: Too many Slaves on one Master.

Solution: Add an additional Master in place of one of the Slaves.

SR	SR	SR
PF	MF	SF

Problem: Slave cannot be attached to rear of Pump Module.

Solution: Move Slave to front position on opposite end of chiller.

	SR	SR
MF	PF	SF

Problem: Pump Module must be on entering waterside of chiller.

Solution: Swap position of Pump with Master Module.

FR	SR	SR	SR
PF	FF	MF	SF

Problem: Slave module is attached to the rear of a Free Cool Module.

Solution: Move this Slave to the right of the last Front Slave.

SR	SR	SR
PF	MF	GF

Problem: Glycol Feeder Module is attached in a front position.

Solution: Move Glycol Feeder Module to rear position & exchange Slave Rear Module for Slave Front Module.

Contact your local Airstack Representative for other configurations.

LEGEND: First Letter

- M = Master Chiller Module (ASP-10A, 15A, 20A)
- S = Slave Chiller Module (ASP-10A, 15A, 20A)
- P = Pump Module (ASP-00P)
- F = Free Cool Module (ASP-00F)
- G = Glycol Feeder Module (ASP-00G)

Second Letter

- F = Front Module
- R = Rear Module

Modules

Single Module

NOTES:

1. All Modules have same dimensions.
2. No obstructions allowed above Condenser Fans.
3. Required service clearance at Module ends: 36".
4. Required Air Intake clearance: 42".
5. Required clearance from any high voltage panel: 42".

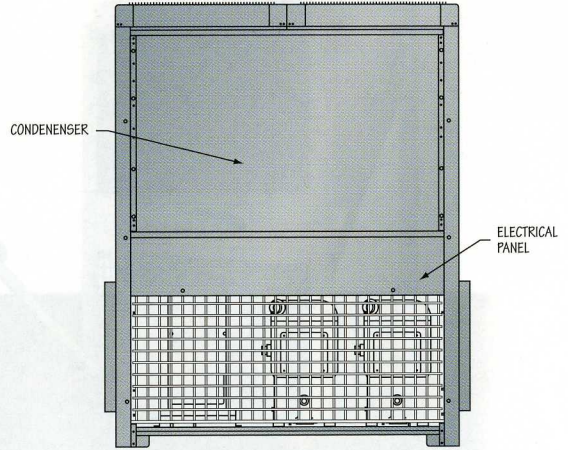
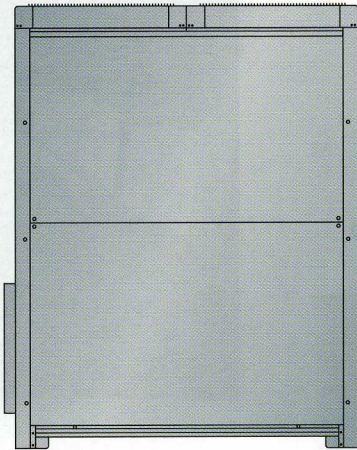
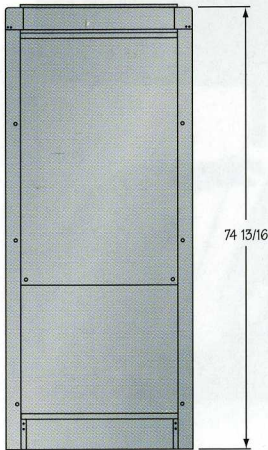
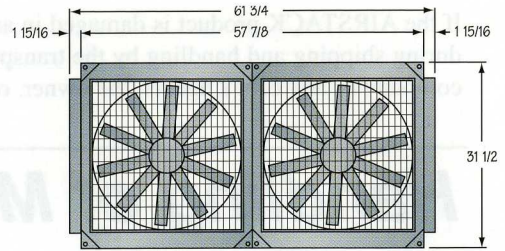

Multiple Modules

NOTES:

1. Modules are bolted together in field.
2. Hardware quantities are specific to each Chiller (# of modules).
3. All Modules have same dimensions.
4. No Obstructions allowed above condenser fans.
5. Required service clearance at Module ends: 36".
6. Required air intake clearance: 42".
7. Required clearance from any high voltage panel: 42".

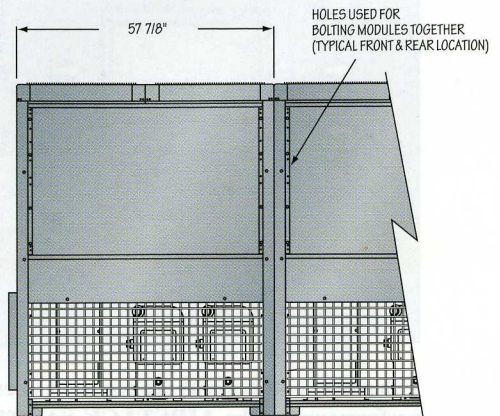
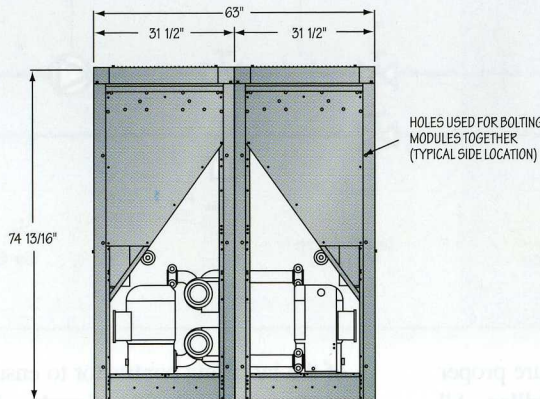
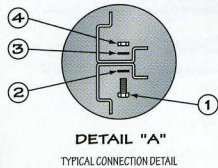
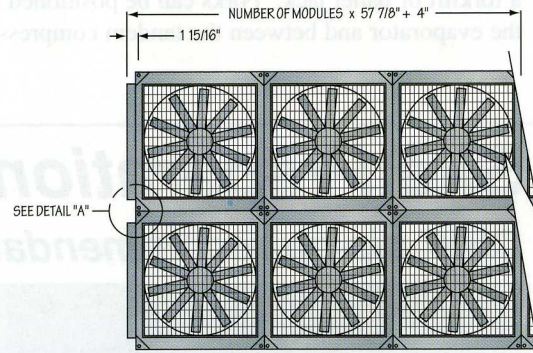

Transportation Claims

If the AIRSTACK product is damaged in any way during shipping and handling by the transportation company or any of its agents, the owner, or installing

contractor should promptly file a claim with the transportation company and so advise AIRSTACK.

Handling of Modules



Fork Lift or Pallet Jack

The modules can safely be lifted and maneuvered with a forklift or pallet jack. Forks can be positioned under the evaporator and between the tandem compressors.



Use of a Crane or other lifting devices

If lifting modules by crane ensure the slings (do not use chains) do not damage the modules. The lift points are at the corners of the base of the chiller. The modules are shipped with the panels pre-fitted. The use of a spreader bar will prevent damage.

Site Preparation

CHW piping recommendations (stubs, valves, etc.)

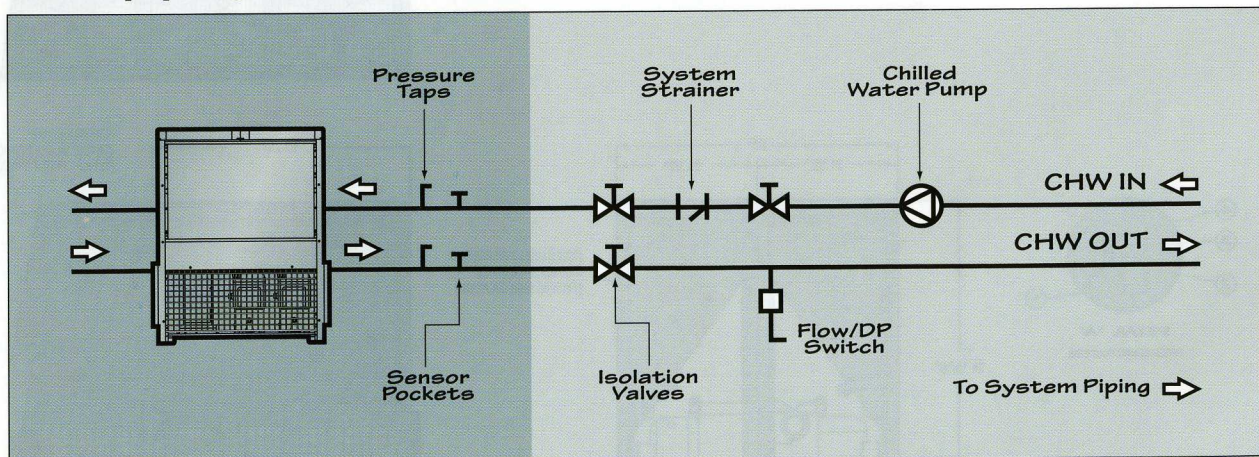

The above components are required to ensure proper performance of the AIRSTACK "ASP" chiller. All piping must be properly supported at coupling connections and suitable intervals. It is the responsibility

of the installing contractor to ensure all water connections conform to local and national codes. The drawing shows piping exiting on right end. Depending on location of master module, exit can be on either end.

Site Preparation

Pipe System Flushing Procedure

Prior to connecting the Airstack chiller to the water/glycol-piping loop, the system piping should be flushed with a detergent and hot water (110-130° F) to remove previously accumulated dirt and/or other organic residue. After removal of organic residue, flushing should continue with a diluted phosphoric, sulfamic, or citric acid mixture if inorganic scale is present in system. (Note: Cleaning chemicals such as Calgon 789™ or equivalent suitable for both organic residue and scale removal may be substituted. **Any other detergents and acids shall not be combined unless approved by chemical manufacturers.** Only chemicals compatible with 316 stainless steel, copper and carbon steel shall be used. **(Any concentrations of hydrochloric or sulfuric acid or chloride containing chemicals shall not be allowed to come in contact with copper brazed 316 stainless steel evaporators.)**)

During the flushing, 30 mesh (max.) Y strainers (or acceptable equivalent) shall be in place in the system piping and examined periodically as necessary to remove collected residue. The flushing process shall take no less than 6 hours, or until the strainers when

examined after each flushing are clean. Old systems with heavy encrustation shall be flushed for a minimum of 24 hours and may take as long as 48 hours before the filters run clean. Detergent and acid concentrations shall be used in strict accordance with the respective chemical manufacturers instructions. After flushing, the system loop shall be purged with clean water for at least one hour to ensure that all residual cleaning chemicals have been removed.

Prior to supplying water to the Airstack chiller, the Water Treatment Specification shall be consulted for requirements regarding the water quality during chiller operation. The Airstack service literature shall be available to the operator and/or service contractor and consulted for guidelines concerning preventative maintenance.



365 S. Oak Street
West Salem, WI 54669

Tel: (608) 786-3400
Fax: (608) 786-3450
E-mail: info@airstack.com
http://www.airstack.com

Airstack® is manufactured by Multistack®

Site Preparation

Clearances

Required Service Clearance At Module Ends	.36"
Required Air Intake Clearance	.42"
Required Clearance From Any High Voltage Panel	.42"



TOP VIEW

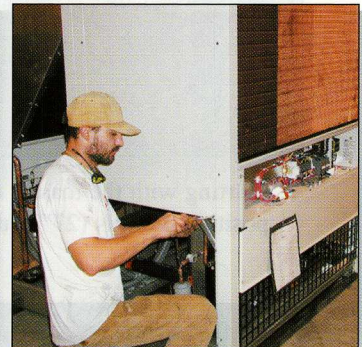

FRONT VIEW

Site Preparation

Water Treatment / Specification

Supply water for the evaporator water circuits shall be analyzed and treated by a professional water treatment specialist who is familiar with the operating conditions and materials of construction specified for the heat exchangers, headers and associated piping. Cycles of concentration shall be controlled such that recirculated water quality for modular chillers using 316 stainless steel brazed plate heat exchangers and carbon steel headers is maintained within the following parameters:

Modular Chiller Water Quality

ph	>7 and <9
Total Dissolved Solids (TDS)	Less than 1000 ppm
Hardness as CaCO3	30 to 500 ppm
Alkalinity as CaCO	30 to 500 ppm
Chlorides	Less than 200 ppm
Sulfates	Less than 200 ppm

Installing Single & Multiple Modules

The modules should be mounted on a level surface with steel rails. This will ensure proper alignment of all fittings.

Rails should run parallel with module water flow (headers). For maximum stability **3 rails should be used, 1 rail for each outside edge and 1 rail to be shared in the center.**

The outside rails should be placed flush with outside frame. Internal rail shares half the distance (2") with Rear and Front modules.

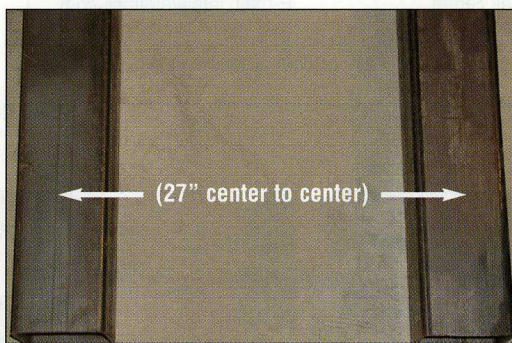

1. Starting with the master front modules, position on rails (27" center to center).

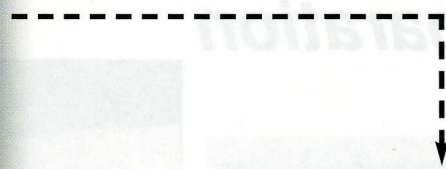
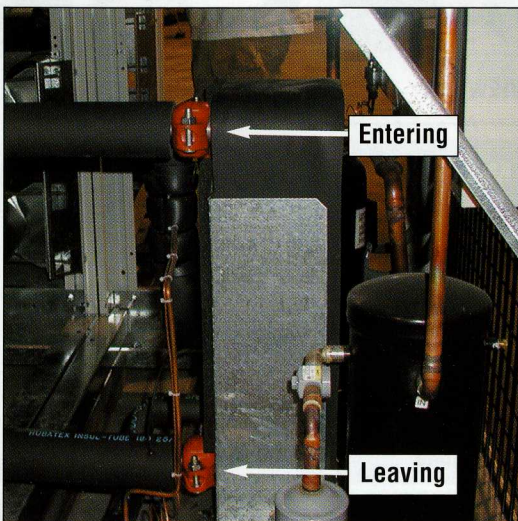

2. Lubricate rails with solid vegetable shortening (Crisco™) or other non-petroleum lubricant.



3. Install the 18-inch long evaporator heat exchanger connecting pipes.

Note: Seismic restraint information available from AIRSTACK Headquarters.

Installing Single and Multiple Modules Continued

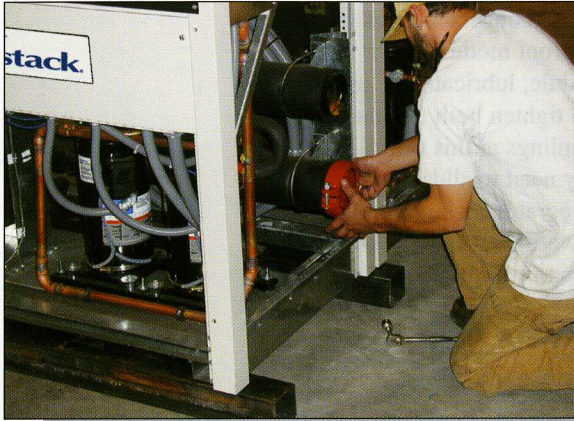

4. Lubricate gaskets with a vegetable based lubricant and hand tighten only. Make sure the bottom connector pipe and the sensor pocket is positioned to accept the sensor for the rear module.

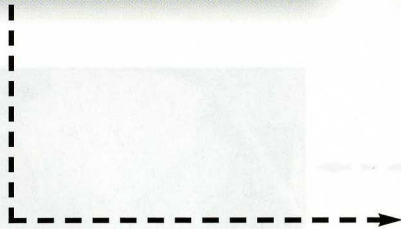

5. Position the rear module on the rails. Align the rear module with the front module.

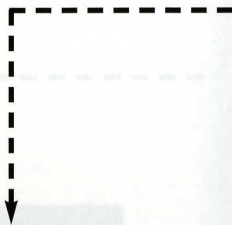

Continue to the next page for step 6 of Airstack module installation.



Installing Single and Multiple Modules Continued

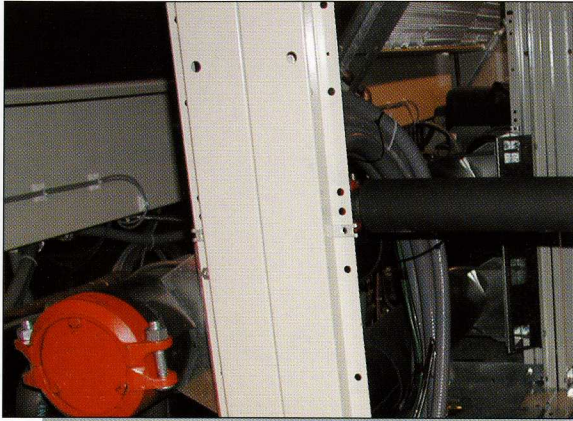

6. Fit the connector pipes from the front module to the rear module, lubricate the gasket and tighten both front and rear couplings at this time. You may need to slide the evaporator mounting plate forward or backward to accomplish this.

7. By loosening the 4 bolts on the plate you can slide the evaporator to the correct distance. If further adjustments are needed, you can loosen the header pipes and front evaporator plate as well.



8. To secure the front and rear modules, align the 3 holes on both ends and install the (6) 3/8" bolts provided.

The Next Step

For installation of subsequent modules follow the same procedure as discussed previously, always begin with the front module. Before installing further rear modules align the 4" water header pipes, lubricate and install the gaskets and couplings connecting to the previous modules header pipe. When bolting the second full module to the first full module align the 3 outer holes on each end and install the 3/8" bolts provided.

Important Module Configurations

ASP-00P Pump Module

1. When present, a Pump Module is only allowed in the "Front" position.
2. Incoming water to the chiller system must enter at the Pump Module.
3. Leaving chilled water may be from either end of the chiller.
4. An ASP-10A, 15A, or 20A Chiller Module may not be attached in the rear module position of a Pump Module.

ASP-00F Free Cool Module

1. When present, incoming system water must enter through the Free Cool Modules prior to entering an ASP-10A, 15A, or 20A Chiller Module.
2. You may **NOT** attach a Rear ASP-10A, 15A, or 20A Chiller Module to a Chiller Module.
3. You may **NOT** attach a Rear ASP-10A, 15A, or 20A Chiller Module to a Front Free Cool Module.
4. Only a Free Cool Module may be attached to the rear of a Pump Module.

ASP-00G Glycol Feeder Module

1. An ASP-00G Glycol Feeder Module may be attached in any rear position.

ASP-10A, 15A, or 20A Chiller Module

1. Maximum number of ASP-10A, 15A, or 20A modules with a single Master Module is 10 (i.e. (1) Front master, (4) Front-Slaves, and (5) Rear-Slaves).
2. You may have more than one Master Module in a single Chiller Bank.
3. Piping sides of an ASP-10A, 15A, or 20A Chiller without Free Cool or Pump Modules attached are field selectable.
4. Master Module must be on Front Side of the Chiller.

Valid Configurations

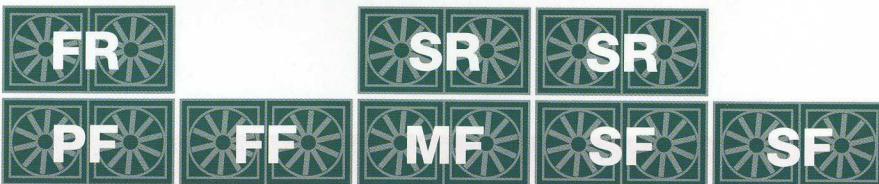
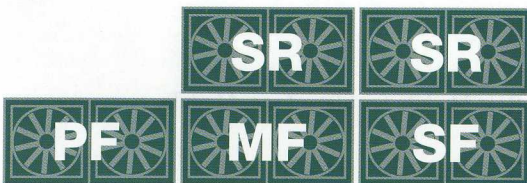
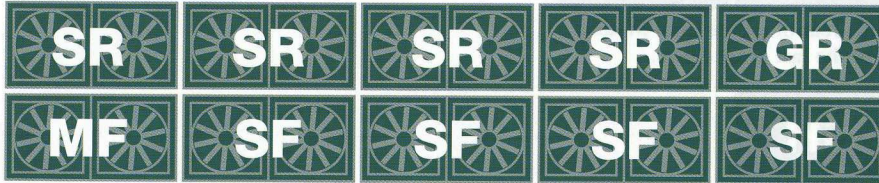

Invalid Configurations

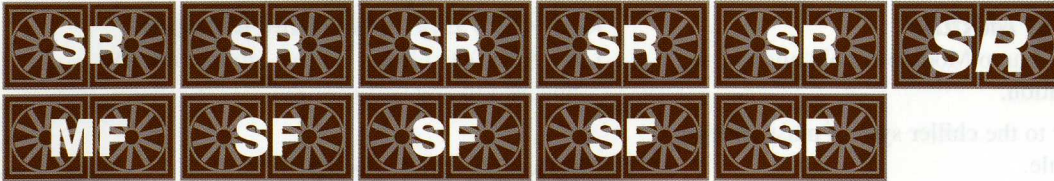

Problem: Too many Slaves on one Master.
Solution: Add an additional Master in place of one of the Slaves.



Problem: Slave cannot be attached to rear of Pump Module.
Solution: Move Slave to front position on opposite end of chiller.



Problem: Pump Module must be on entering waterside of chiller.
Solution: Swap position of Pump with Master Module.



Problem: Slave module is attached to the rear of a Free Cool Module.
Solution: Move this Slave to the right of the last Front Slave.



Problem: Glycol Feeder Module is attached in a front position.
Solution: Move Glycol Feeder Module to rear position & exchange Slave Rear Module for Slave Front Module.

Contact your local Airstack Representative for other configurations.

LEGEND

First Letter

- M** = Master Chiller Module (ASP-10A, 15A, 20A)
- S** = Slave Chiller Module (ASP-10A, 15A, 20A)
- P** = Pump Module (ASP-00P)
- F** = Free Cool Module (ASP-00F)
- G** = Glycol Feeder Module (ASP-00G)

Second Letter

- F** = Front Module
- R** = Rear Module

Installation of Free Cool and Pump Module

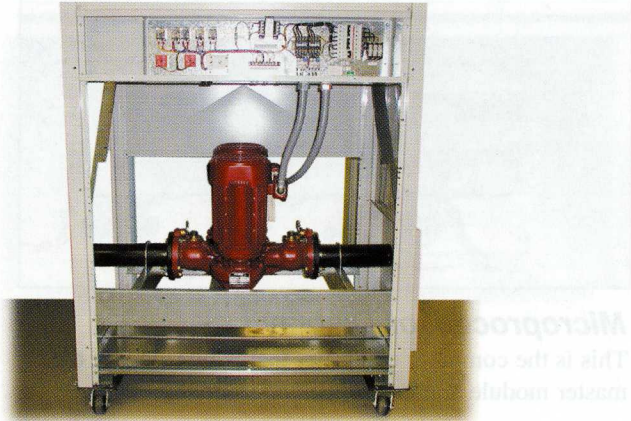

Free cooling and pump modules must be installed at either end of the chiller bank. These modules are not to go in-between or to separate mechanical modules. These modules are to be installed in the same manner as the standard mechanical modules.

Main Power

Locate the power distribution box on the specified end of the chiller. Wire and conduit will need to be run from the distribution box to the front module of each chiller. The wire and conduit may be pre-sized and fabricated at the factory.

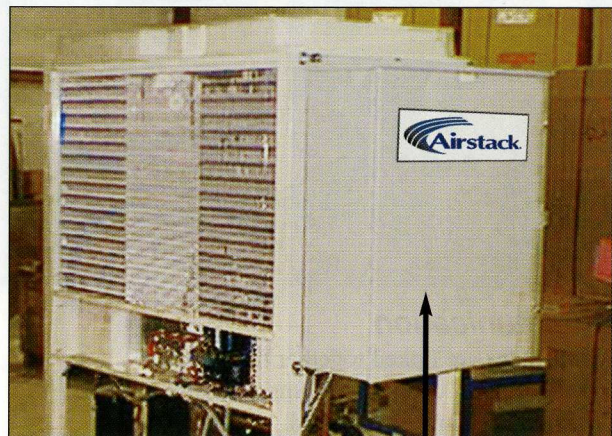

Power Distribution Box

Field Wiring

It is the responsibility of the contractor to supply and install a flow switch in the LCHW piping.

The master module of the ASP chiller has inputs for the following options: remote start/stop, run status, system alarm, 4-20ma input, and remote communication. Supply and return CHW sensors, module communication plugs, and communication interface cables are all provided with the chiller.

The sensors and cables will be installed and tested by the Factory Authorized Start-Up Technician. (See electrical diagrams for locations of all inputs/outputs.)

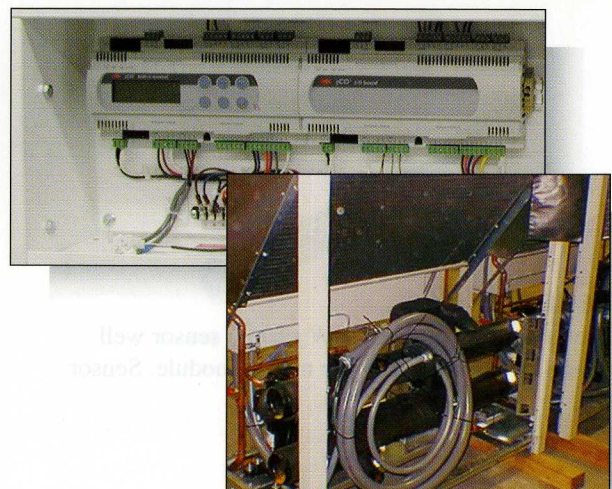

Electronic Components

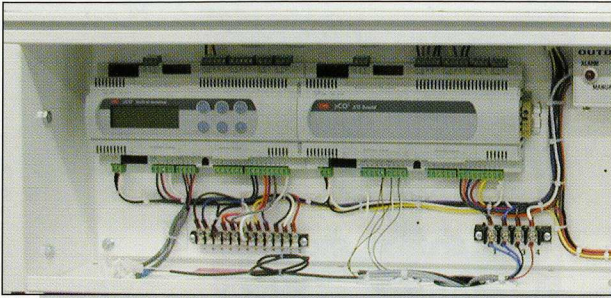

Microprocessor Display

This is the computer controller that is installed on the master module and controls all connected modules.

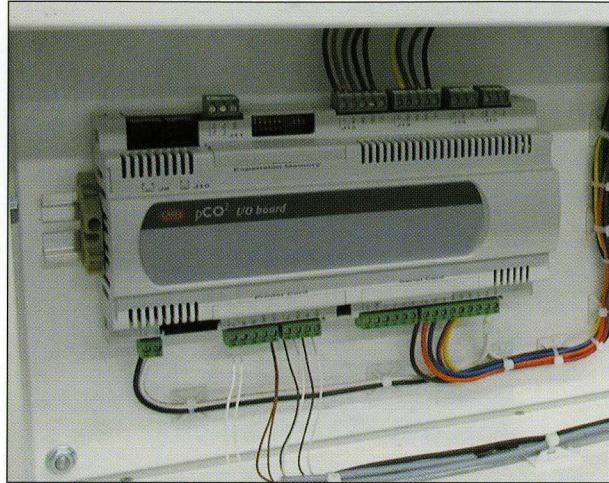

Module Slave Board

Each front and rear module have one of these. This board transfers communication from one module to the next



Communication

All modules are linked together through a communication cable. The communication port is J11 on the module slave board.



Chilled Water Temperature Sensors

These sensors are factory supplied and field installed on the supply and return chilled water header stubs.



Sensor Well

The factory supplied LCHW system sensor well should be installed near the master module. Sensor well is 1/2" pipe thread.



Compressor
Pressure
Transducers

Compressor Pressure Transducers

These are factory installed on the suction and discharge lines of each refrigeration circuit to monitor the suction and discharge pressures.



Airstack, 365 South Oak St., West Salem, WI 54669
 Phone: (608) 786-3400, Fax #: (608) 786-3450
 E-mail: info@airstack.com
 http://www.airstack.com

ASP INSTALLATION CHECKLIST AND REQUEST FOR AUTHORIZED START-UP ENGINEER

CUSTOMER: _____
JOB NAME: _____
JOB LOCATION: _____
CUSTOMER ORDER NO.: _____

The work as checked below is in process and will be completed by: Date _____ . The service of a Airstack Authorized Start-up Engineer is requested on this date and it is understood that if the work checked below is not completed, the engineer's time and expenses will be billed to us by Airstack. Terms Net 30 days. *Airstack to be notified at least ten (10) working days in advance of the start-up date.*

CHILLED WATER	Yes	No	Not Applicable
Piping complete and connected to Airstack Units.	<input type="checkbox"/>	<input type="checkbox"/>	<input type="checkbox"/>
Water system filled and vented.	<input type="checkbox"/>	<input type="checkbox"/>	<input type="checkbox"/>
Pumps installed (Rotation checked).	<input type="checkbox"/>	<input type="checkbox"/>	<input type="checkbox"/>
Recommended strainers installed.	<input type="checkbox"/>	<input type="checkbox"/>	<input type="checkbox"/>
Controls (3-way valves & by-pass valves, etc.) operable.	<input type="checkbox"/>	<input type="checkbox"/>	<input type="checkbox"/>
Water system operated and flow balanced to meet unit design requirements.	<input type="checkbox"/>	<input type="checkbox"/>	<input type="checkbox"/>
Strainers checked for unusual debris.	<input type="checkbox"/>	<input type="checkbox"/>	<input type="checkbox"/>
Flow or differential pressure switch installed.	<input type="checkbox"/>	<input type="checkbox"/>	<input type="checkbox"/>

ELECTRICAL	Yes	No	Not Applicable
Power wiring complete and in accordance with nameplate rating on unit and prepared for connection in accordance with installation manual.	<input type="checkbox"/>	<input type="checkbox"/>	<input type="checkbox"/>
NOTE: No power is to be applied to unit prior to inspection by authorized engineer.			
All interlock wiring complete between control panel and complies with Airstack specifications and with applicable codes.	<input type="checkbox"/>	<input type="checkbox"/>	<input type="checkbox"/>

MISCELLANEOUS	Yes	No	Not Applicable
Chiller sensor wells, gauges, controls installed	<input type="checkbox"/>	<input type="checkbox"/>	<input type="checkbox"/>
A minimum system load of 50% of total building load is available for testing and adjusting controls.	<input type="checkbox"/>	<input type="checkbox"/>	<input type="checkbox"/>

We understand that authorized representatives of the installing electrical and piping contractor must be available during the start-up period and that coordination is our responsibility.

We further understand that the services of an Authorized Start-up Engineer will be furnished for a period of not more than sixteen (16) consecutive normal working hours and we agree that a charge for time and expenses will be made by Airstack if services are required for longer than sixteen (16) consecutive normal working hours or if repeat calls are required through no fault of Airstack.

Signed _____

 Title

 Company Name

 Company Location

 Company Telephone

 Job Location Telephone



P.O. Box 854
365 S. Oak Street
West Salem, WI 54669

Tel: (608) 786-3400
Fax: (608) 786-3450
E-mail: info@airstack.com
<http://www.airstack.com>

Airstack® is manufactured by Multistack®

Contact: Your local **AIRSTACK**
Air Cooled Packaged Chiller
representative for additional
information or assistance.
ACPI080805



Wiring Information

Airstack Packaged "ASP" Pump Module

Drawing #'s

2000-0199

2000-0077

2000-0198

AIRSTACK®

Manufactured By MULTISTACK®

1065 Maple Ave..

Sparta, WI 54656

Phone #: (608) 366-2400 Fax #: (608) 366-2450

Web Site: www.airstack.com

5/5/07 good #

REVISED & REDRAWN ADDED 1 THRU 3 HP TO WIRE TABLE 11-1-2001 KOMPERUD	REVISED WIRING TO FIX FLOW IN FAULT CONDITION. 5-3-02 GILBERTSON	REVERSED WIRING TO MAKE PUMPS RUN THE RIGHT DIRECTION. 9/23/02 GILBERTSON	FLOW SWITCH WAS SUPPLIED BY OTHERS 2-18-2003 KOMPERUD	REF. DWG# C2000-0341 WAS C2000-0189 ADDED DIFF. PRESSURE & CURRENT TO LEGEND 7-8-2003 KOMPERUD	TS2 WAS Δ 10-28-2003 KOMPERUD	CHANGED VALUES IN WIRE TABLE 4-21-04 ERDMANN	REVISED TEXT TO MS INPUT ON TS2 3-2-05 PRUSS	A	B	C	D	E	F	G	H
REFERENCE DWGS: S.D. C2000-0077 W.D. C2000-0198 SIMILAR TO:								III MULTISTACK West Salem, Wisconsin 54669 ALL DIMENSIONS IN INCHES / DO NOT SCALE DRAWINGS FIRST USED ON STD ENGR SPEC ASSY NO: ALL VOLTAGES							
DRAWN BY: MWK DATE: 9-13-2000								CHECKED BY: DATE:							
ENGR: APPR: DATE:								SCALE: NONE							

WIRE TABLE		L1, L2, L3						
WIRE LOCATION		1 THRU 3	5	7.5	10	15	20	25
PUMP HP		#12	#10	#8	#6	#6	#6	#4
208/230 V		#12	#12	#12	#10	#10	#8	#8
460/575 V								
WIRE LOCATION		GROUND WIRE						
PUMP HP		1 THRU 3	5	7.5	10	15	20	25
208/230 V		#14	#14	#10	#10	#10	#8	#8
460/575 V		#14	#14	#14	#10	#10	#10	#10

LEGEND	
FS	FLOW SWITCH, DIFFERENTIAL PRESSURE
M	PUMP MOTOR
MC	CONTACTOR
OL	OVERLOAD RELAY, CURRENT
TS	CONTROL TERMINAL

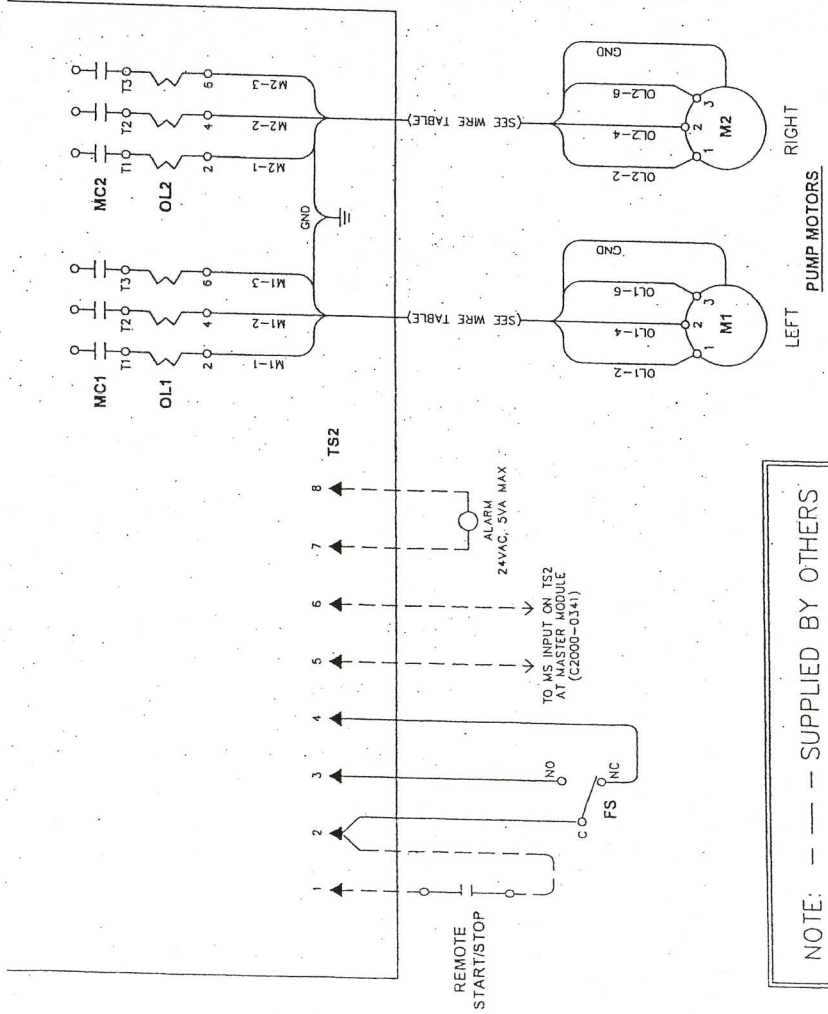
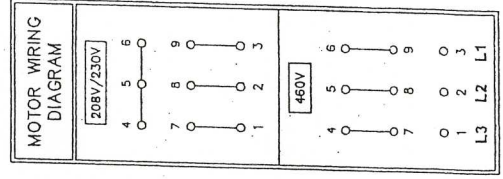

NOTE: --- SUPPLIED BY OTHERS
MIN. WIRE SIZE, 18 AWG

REV. BY	DATE	REVISION	F		B		2000-0077		F		
A	5/3/02	GILBERTSON	E		D		C		B		
B	9/23/02	GILBERTSON	E		D		C		B		
C	2-17-2003	KOMPERUD	E		D		C		B		
D	7-2-03	ERDMANN	E		D		C		B		
E	2-17-05	PRUSS	E		D		C		B		
F	3-2-05	PRUSS	E		D		C		B		
REVERSED WIRING TO FIX FLOW IN FAULT CONDITION. REVERSED WIRING TO MAKE PUMPS RUN THE RIGHT DIRECTION. 9/23/02 GILBERTSON			CHANGED F1 TO CB4 FLOW SWITCH WAS SUPPLIED BY OTHERS 2-17-2003 KOMPERUD ADDED FS DESIGNATION FOR FLOW SWITCH AND REVERSED LEGEND. 7-2-03 ERDMANN			REVERSED WIRING FROM CB3 & CB2 TO TB1 2-17-05 PRUSS			REVERSED TEXT TO MS INPUT ON TS2 3-2-05 PRUSS		
SIMILAR TO:			DRAWN BY: MIWK DATE: 1-3-2000			CHECKED BY:			ENGR. APPR. DATE:		
ALL DIMENSIONS IN INCHES / DO NOT SCALE DRAWINGS			ALL VOLTAGES			SCALE: NONE			SCHEMATIC PUMP PACKAGE		
WEST SALEM, WISCONSIN 54669			MULTISTACK			2000-0077			F		

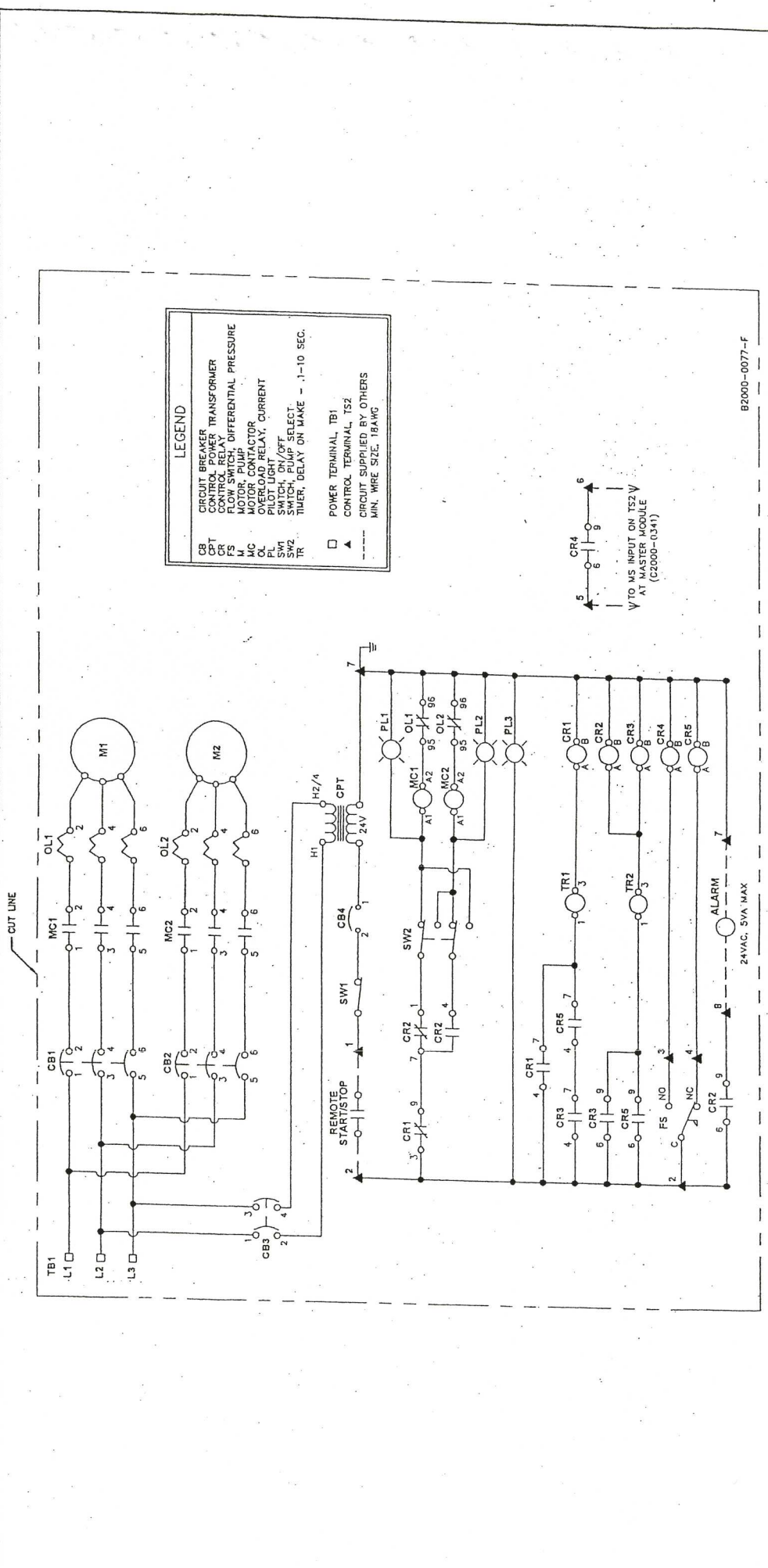

PROJECT	A	B	C	D	E	F	G	H	I	J	K	L	M	N	O	P	Q	R	S	T	U	V	W	X	Y	Z
DESCRIPTION	MIMUL TISTACK																									
DATE	2000-0198																									
REVISION	WIRING DIAGRAM PUMP PACKAGE CONTROL PANEL																									
DESIGNED BY	West Salem, Wisconsin 54669																									
CHECKED BY	ALL VOLTAGES																									
DATE	DATE 9-19-2000 DATE																									
SCALE	NONE																									
PROJECT NO.	MIMUL TISTACK																									
DRAWING NO.	MIMUL TISTACK																									

LEGEND

CB CIRCUIT BREAKER
 CR CONTROL RELAY
 CPT TRANSFORMER
 MC CONTACTOR
 OL OVERLOAD RELAY
 SW SWITCH
 TS TERMINAL BLOCK, POWER
 TR TIMER, DELAY ON MAKE
 TS TERMINAL STRIP, CONTROL

WIRE TABLE

WIRE LOCATION	CB'S to MC'S
PUMP HP	1 THRU 3 5 7.5 10 15 20 25
208/230 V	#12 #10 #8 #6 #4
460/575 V	#12 #10 #10 #10 #10 #8 #6

WIRE LOCATION	TB1 to CB1
PUMP HP	1 THRU 3 5 7.5 10 15 20 25
208/230 V	#10 #8 #6 #6 #6 #4 #4
460/575 V	#10 #10 #10 #8 #8 #6 #6

NOTE: REFERENCE DWG # 2000-0200 FOR INDIVIDUAL PART DESCRIPTIONS.

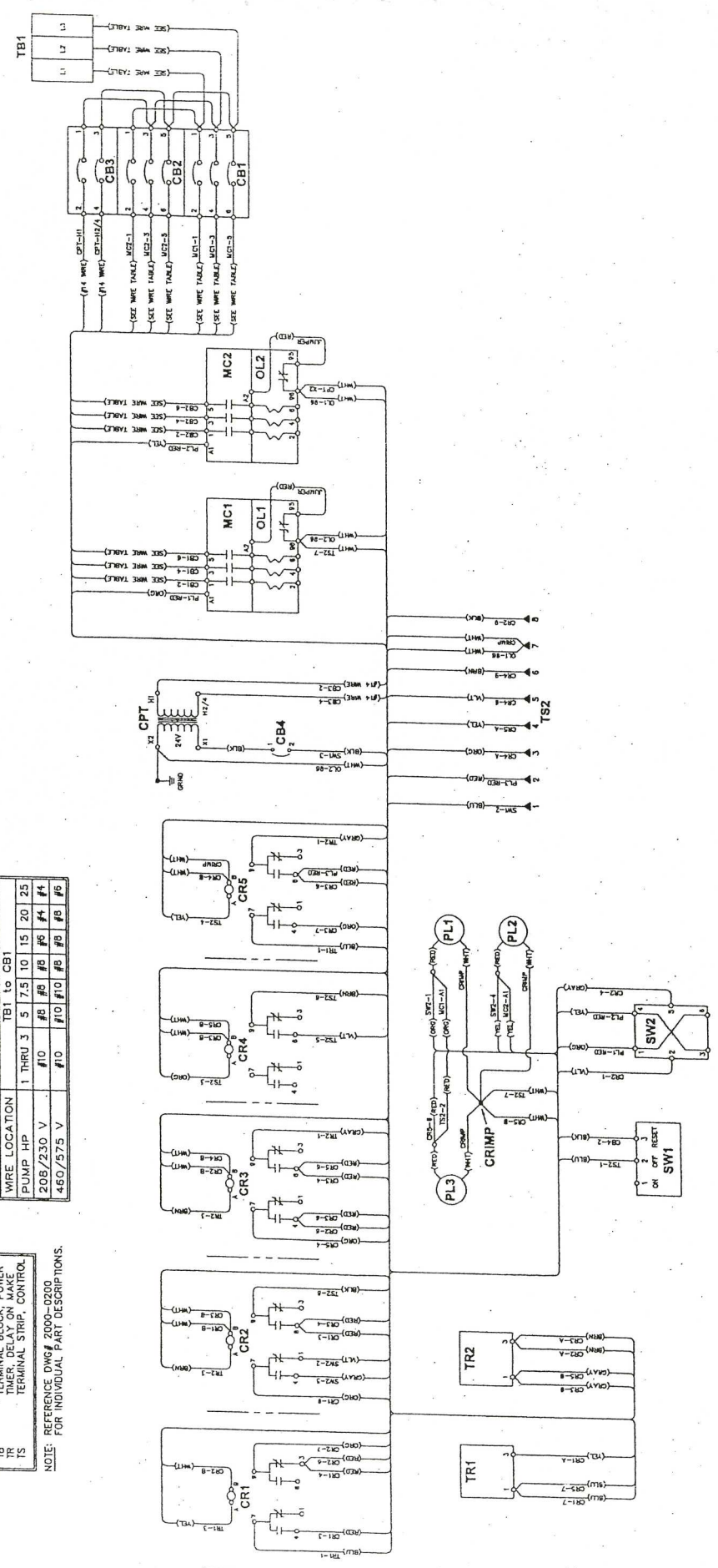

PROJECT	A	B	C	D	E	F	G	H	I	J	K	L	M	N	O	P	Q	R	S	T	U	V	W	X	Y	Z
DESCRIPTION	MIMUL TISTACK																									
DATE	2000-0198																									
REVISION	WIRING DIAGRAM PUMP PACKAGE CONTROL PANEL																									
DESIGNED BY	West Salem, Wisconsin 54669																									
CHECKED BY	ALL VOLTAGES																									
DATE	DATE 9-19-2000 DATE																									
SCALE	NONE																									
PROJECT NO.	MIMUL TISTACK																									
DRAWING NO.	MIMUL TISTACK																									



Wiring Information

Airstack Packaged "ASP"

Dual Circuit Mechanical Cooling Modules

Drawing #'s

631-C005-01

631-C005-02

631-C005-03

2000-0341

2000-0342

AIRSTACK®

Manufactured By MULTISTACK®

365 South Oak Street

West Salem, WI 54669

Phone #: (608) 786-3400 Fax #: (608) 786-3450

Web Site: www.airstack.com

MULTISTACK A-MEMBER OF HARBUK HOLDING CORP.		B 631-C005-01	
West Salem, Wisconsin 54669		SCHEMATIC	
ALL DIMENSIONS IN INCHES / DO NOT SCALE DRAWINGS		ASP	
JOB NAME: APC		TANDEM SCROLL COMPRESSORS	
FIRST USED ON: _____		SCALE: NONE	
DRAWN BY: TJG		ENGR: _____	
DATE: 12-16-02		DATE: _____	
CHECKED BY: _____		APPROV: _____	
DATE: _____		DATE: _____	

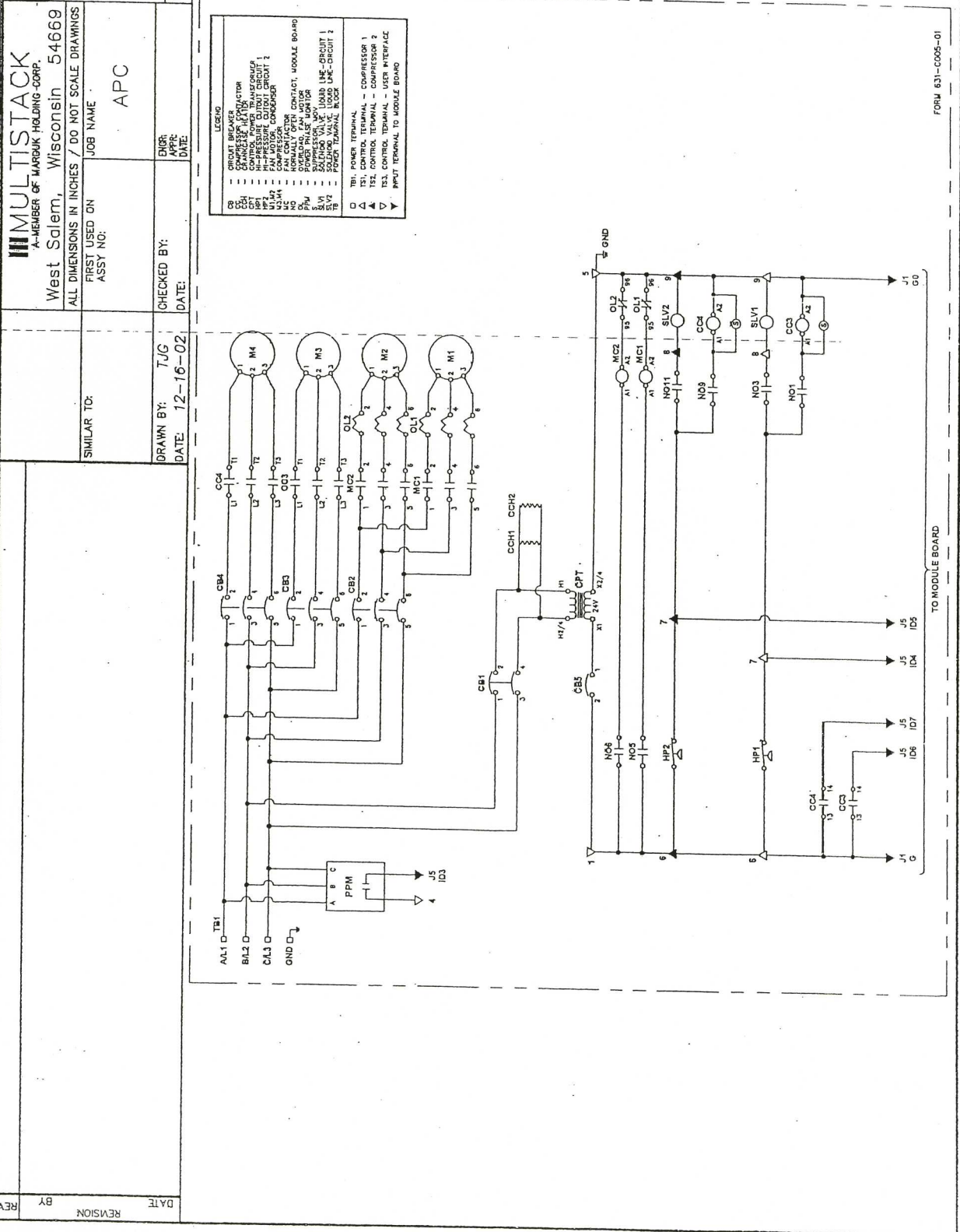

- LEGEND**
- CB - CIRCUIT BREAKER
 - CCH - CONTACTOR
 - HP - HIGH PRESSURE SWITCH
 - MC - MOTOR CONTACTOR
 - NO - NORMALLY OPEN CONTACT
 - NC - NORMALLY CLOSED CONTACT
 - SP - SPENDING VALVE
 - SLV - SOLID LINE VALVE
 - SV - SOLID VALVE
 - TS - THERMISTOR
 - TS1 - THERMISTOR 1
 - TS2 - THERMISTOR 2
 - TS3 - THERMISTOR 3
 - TS4 - THERMISTOR 4
 - TS5 - THERMISTOR 5
 - TS6 - THERMISTOR 6
 - TS7 - THERMISTOR 7
 - TS8 - THERMISTOR 8
 - TS9 - THERMISTOR 9
 - TS10 - THERMISTOR 10
 - TS11 - THERMISTOR 11
 - TS12 - THERMISTOR 12
 - TS13 - THERMISTOR 13
 - TS14 - THERMISTOR 14
 - TS15 - THERMISTOR 15
 - TS16 - THERMISTOR 16
 - TS17 - THERMISTOR 17
 - TS18 - THERMISTOR 18
 - TS19 - THERMISTOR 19
 - TS20 - THERMISTOR 20
 - TS21 - THERMISTOR 21
 - TS22 - THERMISTOR 22
 - TS23 - THERMISTOR 23
 - TS24 - THERMISTOR 24
 - TS25 - THERMISTOR 25
 - TS26 - THERMISTOR 26
 - TS27 - THERMISTOR 27
 - TS28 - THERMISTOR 28
 - TS29 - THERMISTOR 29
 - TS30 - THERMISTOR 30
 - TS31 - THERMISTOR 31
 - TS32 - THERMISTOR 32
 - TS33 - THERMISTOR 33
 - TS34 - THERMISTOR 34
 - TS35 - THERMISTOR 35
 - TS36 - THERMISTOR 36
 - TS37 - THERMISTOR 37
 - TS38 - THERMISTOR 38
 - TS39 - THERMISTOR 39
 - TS40 - THERMISTOR 40
 - TS41 - THERMISTOR 41
 - TS42 - THERMISTOR 42
 - TS43 - THERMISTOR 43
 - TS44 - THERMISTOR 44
 - TS45 - THERMISTOR 45
 - TS46 - THERMISTOR 46
 - TS47 - THERMISTOR 47
 - TS48 - THERMISTOR 48
 - TS49 - THERMISTOR 49
 - TS50 - THERMISTOR 50

REV.	BY	DATE	REVISION
REFERENCE DWGS:		MULTISTACK - A MEMBER OF HARTUNG-HOLDING CORP. West Salem, Wisconsin 54669	
SIMILAR TO:		FIRST USED ON: _____ ASSY NO.: _____ JOB NAME: APC	
DRAWN BY: TUG		CHECKED BY: _____	
DATE: 12-16-02		DATE: _____	
		SCALE: NONE	
		WIRING DIAGRAM CONTROL PANEL ASP DUAL CIRCUIT MODULES	
		B. 631-C005-02	

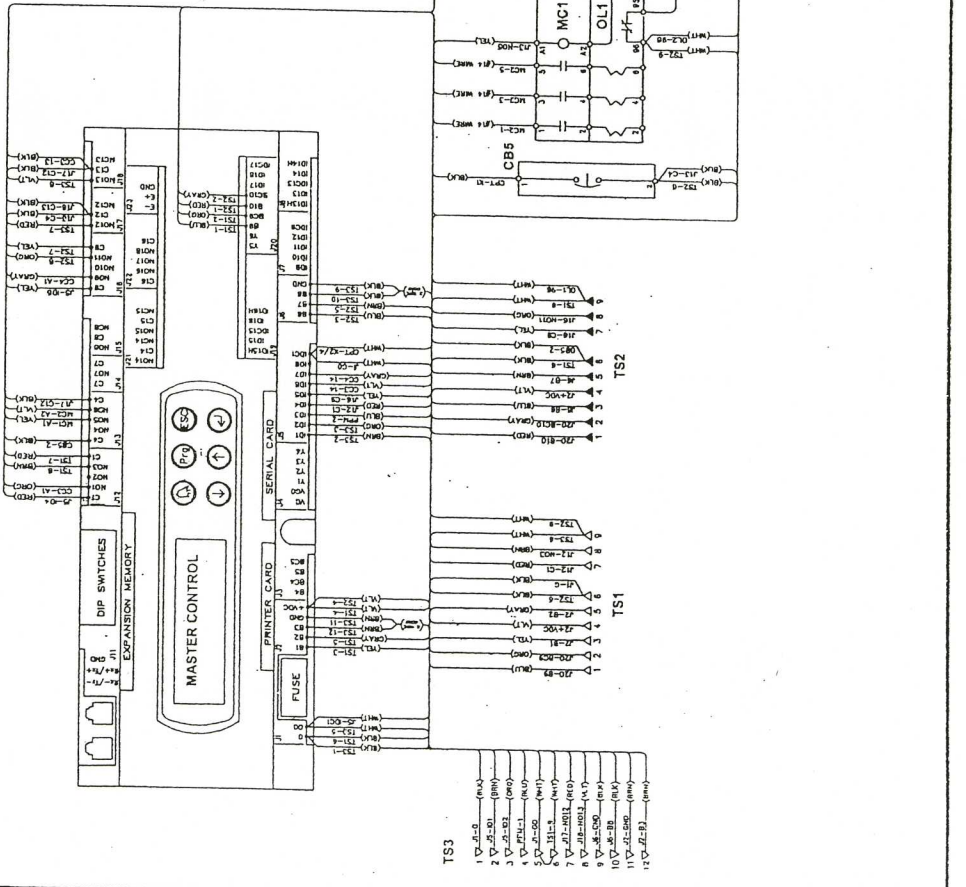

LEGEND

CB CIRCUIT BREAKER
CC COMPRESSOR CONTACTOR
CCT COMPRESSOR THERMISTOR
MC MOTOR CONTACTOR
OL OVERLOAD RELAY
TB TERMINAL BLOCK
TS TERMINAL STRIP

WIRE TABLE

WIRE LOCATION	400V	400V	400V
TB1 to CB4	#0	#0	#0
CB4 to CC4	#12	#12	#12
CB3 to CC3	#12	#12	#12

REFERENCE DWGS: **MULTISTACK**
 - A MEMBER OF HAWK HOLDING CORP.
 West Salem, Wisconsin 54669

BY: **B. 631-C005-03**

REVISION DATE

SIMILAR TO: **APC**

ASSY NO: **ASP**

JOB NAME: **DUAL CIRCUIT MODULES**

SCALE: **NONE**

ENGINEER: **NONE**

DATE: **12-16-02**

CHECKED BY: **T.J.G.**

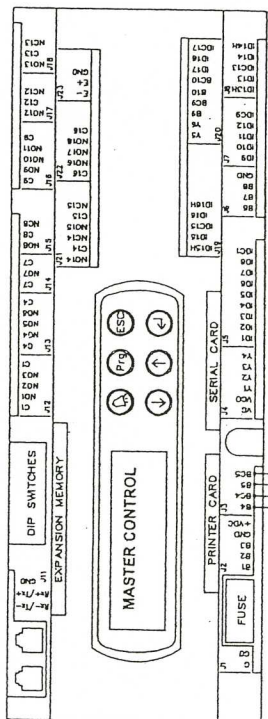

WIRE TABLE

WIRE LOCATION	10 TON (NOMINAL)	15 TON (NOMINAL)	20 TON (NOMINAL)
CC3 to M3	#12	#12	#10
CC4 to M4	#12	#12	#10

LEGEND

- CB CIRCUIT BREAKER
- CC CONTACTOR
- CCH CRANKCASE HEATER
- HP HIGH PRESSURE SWITCH
- LPT LOW PRESSURE TRANSDUCER
- MC MOTOR
- M3, M4 COMPRESSOR
- OL OVERLOAD RELAY, FAN
- SLV SOLENOID VALVE
- TS TERMINAL STRIP

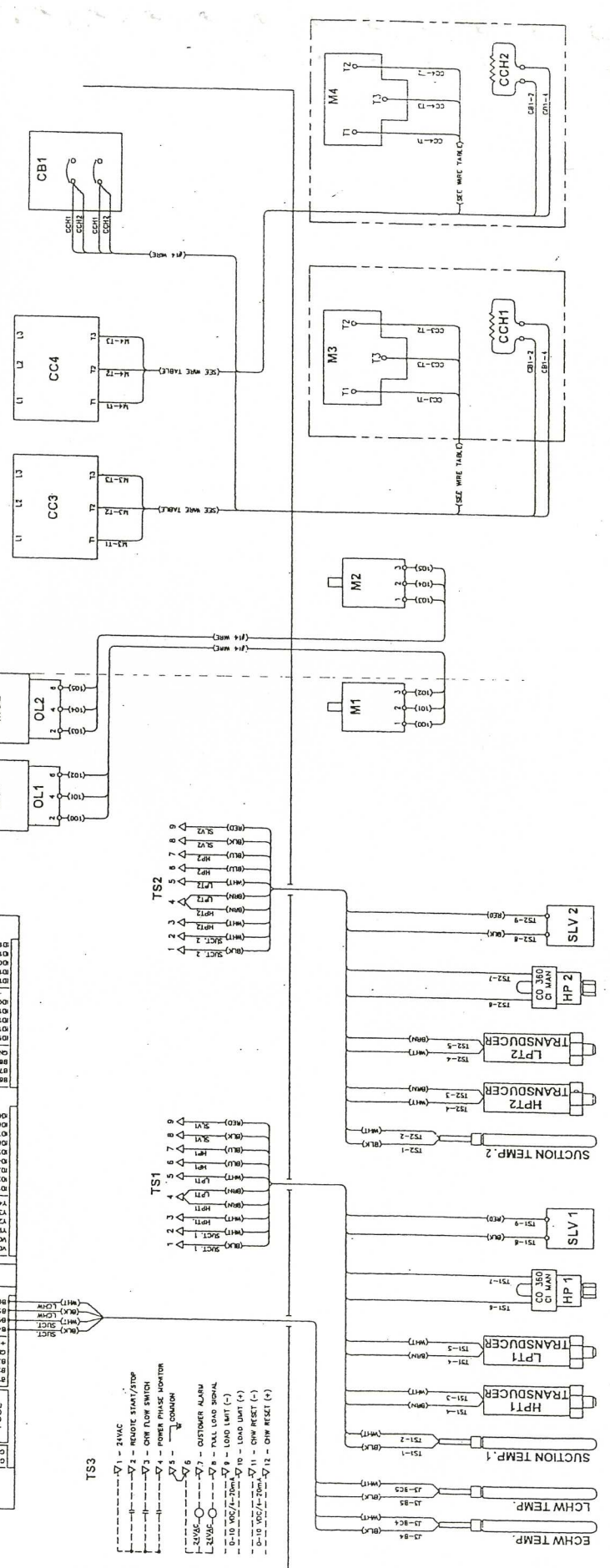

REV. BY DATE	REMOVED TS2-5 AND OUTDOOR AMBIENT TEMP	6-9-2003 KMPERUD	REFERENCE DWGS:	MULTISTACK	B	2000-0341	A
	REMOVED MEMBER OF MARDUK HOLDING	2-15-2005 PRUSS			West Salem, Wisconsin 54669	SYSTEM INTERCONNECT DIAGRAM	
DRAWN BY: TJG			APPROVED BY:	SCALE: NONE			
DATE: 8-1-01			CHECKED BY:				
DATE: 8-1-01			DATE:				
SIMILAR TO:			FIRST USED ON ASSY NO:	STD ENGR SPEC			
ALL DIMENSIONS IN INCHES / DO NOT SCALE DRAWINGS							

- NOTES**
- COMPONENTS & WIRING BY OTHERS. (#16 MIN. WIRE)
 - INPUTS TO TERMINALS 1 THRU 6 OF TS2 MUST BE WIRED CLOSED IF NOT USED.
 - EXTERNAL INPUTS: (CLOSED TO OPERATE)
 - EX1 - REQUIRES MANUAL RESET
 - EX2 - AUTO RESET: REMOTE START/STOP
 - EX4 - AUTO RESET: POWER/PHASE MONITOR
 - EXTERNAL OUTPUTS:
 - FS - FLOW SWITCH (CHILLED WATER)
 - MS - AUX. INTERLOCK (CHILLED WATER PUMP STARTER)
 - CHILLED WATER RESET - SELECTABLE 0-10V OR 4-20 mA
 - LOAD LIMIT RESET - SELECTABLE 0-10V OR 4-20 mA

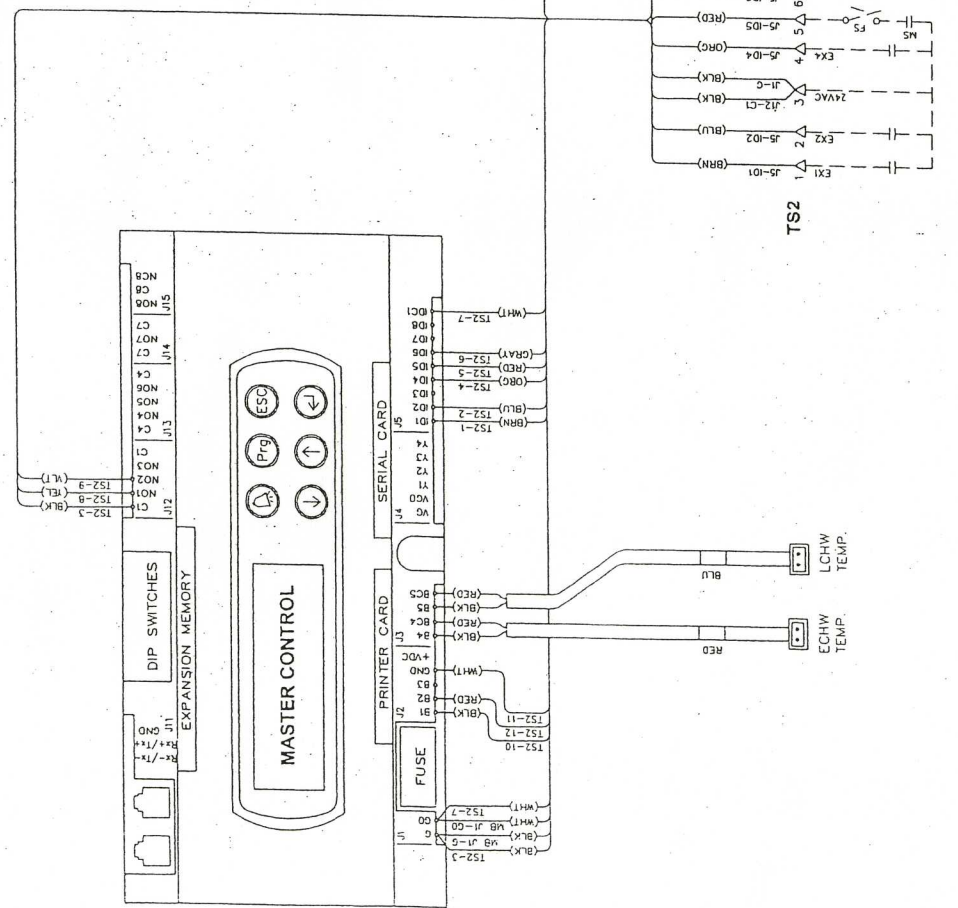

MB, A-C, J1-CO
TO 24 VAC CONNECTS
OF THE RESET MODULE BOARD

DATE: 2/15/2005 OF KARDUK HOLDING REMOVED MEMBER	REFERENCE DWGS:	MULTISTACK	B	2000-0342
	SIMILAR TO:	West Salem, Wisconsin 54669 ALL DIMENSIONS IN INCHES / DO NOT SCALE DRAWINGS FIRST USED ON STD ENGR SPEC ASSY NO:	COMMUNICATIONS INTERCONNECT DIAGRAM ASP TANDEM SCROLL COMPRESSORS	
DRAWN BY: TJG DATE: 10-29-01	CHECKED BY:	SCALE: NONE		
		DPR: _____ DATE: _____		

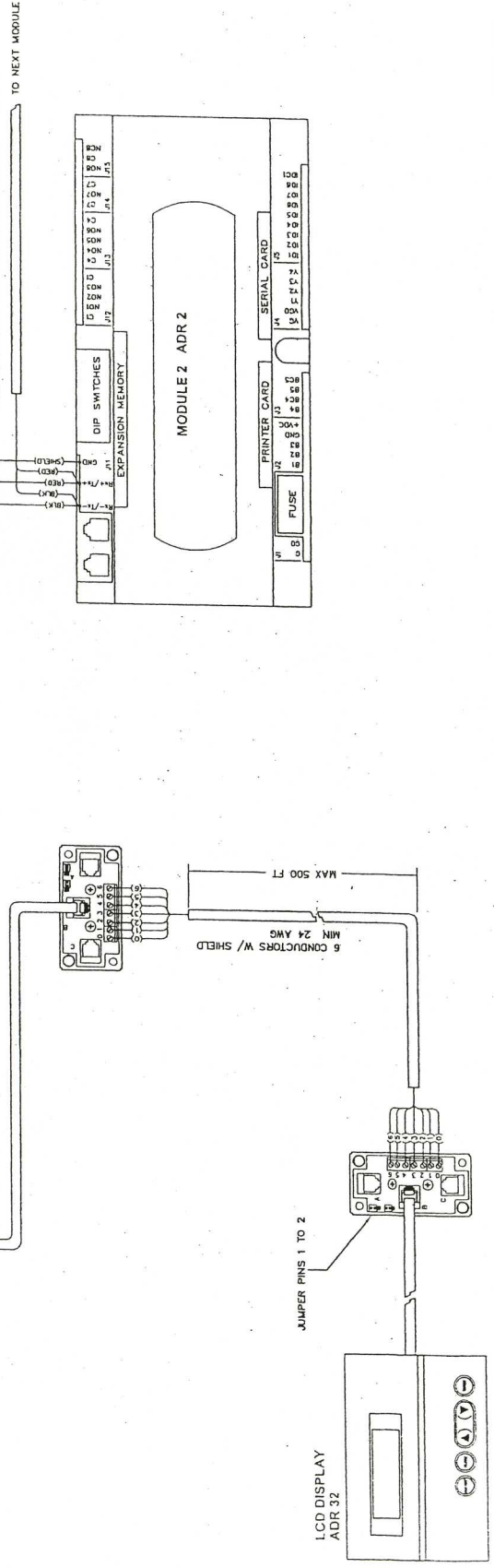
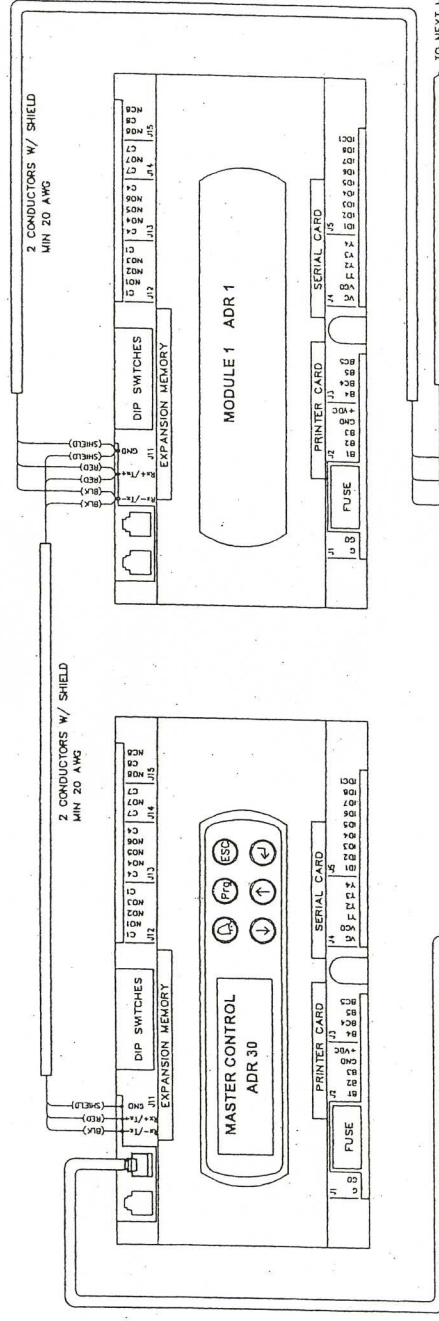



factory check valves per factory telcon.

Submittal

ARMSTRONG

SUBMITTAL

Series 4280
1.5x1x8
Centerline Disc. End Suction Motor Mounted Pump

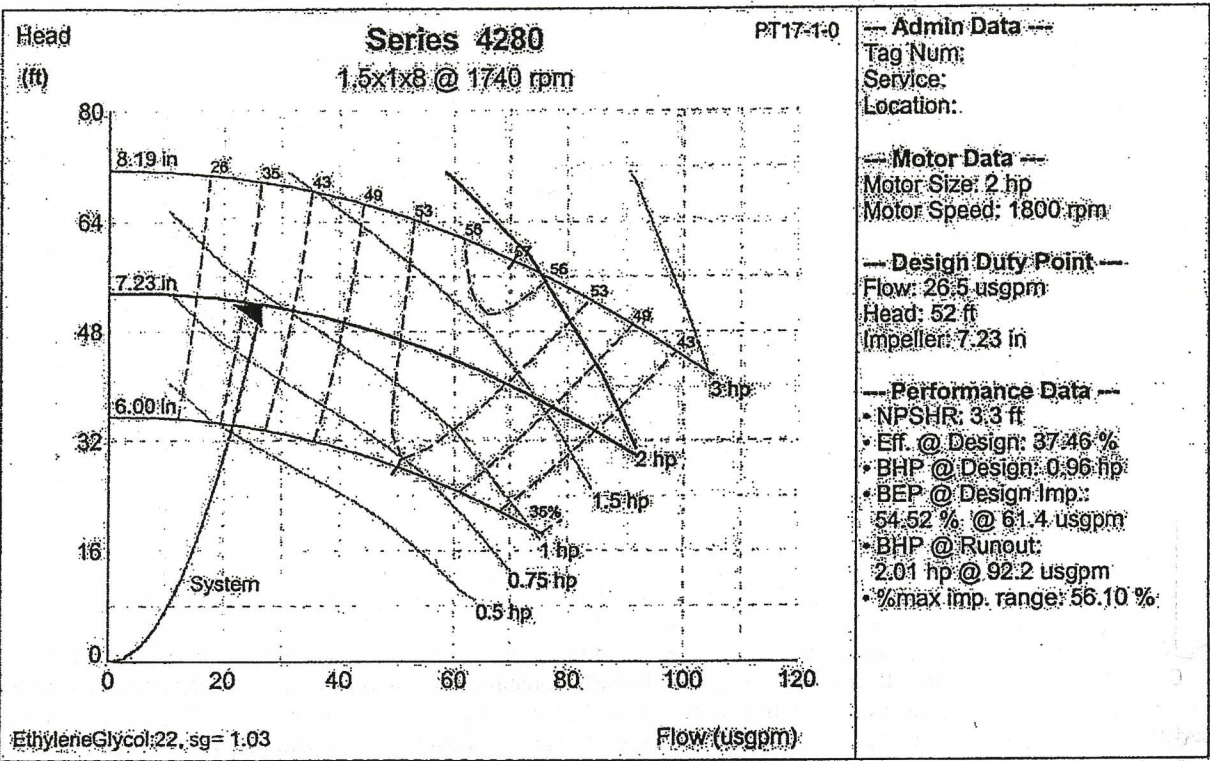

EARTH TECH, INC.

APPROVED SUBMIT SPECIFIED ITEM

APPROVED AS NOTED REVISE AND RESUBMIT

NOT APPROVED

Review is only for the... of the project and... in the contract... including, but not limited to... conformed and... and technical... of all other... work.

By: *John Stura* Date: *January 22, 06*



NO EXCEPTIONS TAKEN REVISE AND RESUBMIT

ARMSTRONG Series 4280 1.5x1x8

Centerline Disc. End Suction Motor Mounted Pump

The contractor shall be responsible for details and accuracy, for confirming and correlating all quantities and dimensions, for selecting fabrication processes, for techniques of assembly, and for performing the work in a safe manner.

Representative: Multistack
 365 South Oak St. West Salem, WI
 Phone: 608-786-3400, Fax: 608-786-3450
Order No.: _____ **Date:** _____
Submitted by: Scott DeGier **Date:** 1/20/2006
Approved by: _____ **Date:** _____

Project Number: _____ **Date:** 1/23/06
Engineer: *John DeGier*
 By: _____
 OFFICE OF PHYSICAL PLANNING & CONSTRUCTION
 UNIVERSITY OF CALIFORNIA, SANTA CRUZ

PUMP DESIGN DATA	
Tag Num:	
Service:	
Location:	
No. of Pumps:	1
Capacity:	26.5 usgpm
Head:	52 ft
Piping:	Single
Suction Pressure:	0 ft
Liquid:	Ethylene Glycol 22
Op. Temperature:	24 °F
Viscosity:	4.43 cp
Sp. Gravity:	1.03
Suction Size:	1.5 in
Discharge Size:	1 in

MOTOR DESIGN DATA	
Motor Supplier:	Factory Choice
Motor Size:	2 hp @ 1800 rpm
Frame Size:	145JM
Enclosure:	ODP
Cycle/Phase/Voltage:	60/3/230
Motor Eff:	Std
Insulation:	Class "B" Insulation (266.0 °F)
Starter Config:	DOL
Full Load/Starting (A):	6.8 / 50.0

MATERIALS OF CONSTRUCTION	
Construction	BF (Bronze Fitted)
ANSI Flange Rating	125 lb. (Cast Iron)
Impeller	Bronze (B584-844)
Casing	Cast Iron (A48-30)
Casing Gasket	Confined Non-Asbestos Fiber
Adapter	Cast Iron (A278-30)
Motor Shaft	Carbon Steel
Shaft Sleeve	Bronze (B584-844)

MECHANICAL SEAL DESIGN DATA	
Manufacturer	John Crane
Manu. Code [JC 21]	JC 21, OP171
Seal Type	Inside Unbalanced
Rotating Face	Carbon
Stationary Seat	Ceramic
Secondary Seal	EPDM
Springs	Stainless Steel
Rotating Hardware	Stainless Steel

Pressure (PSI)	Operating Limits Temperature (°F)
150	270
120	270
90	270
60	270
30	270
0	270

Pressure (PSI) vs. Operating Limits Temperature (°F)

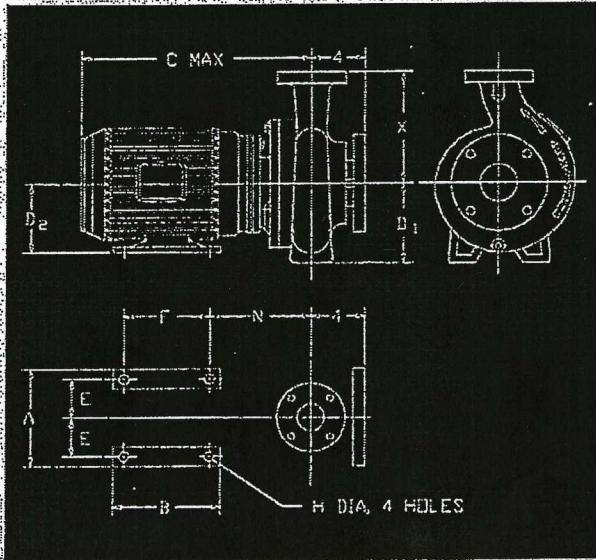

DIMENSIONAL DATA (inches) (NOT for CONSTRUCTION)											
B	Cmax	D1	D2	E	F	N	H	X	TotWgt	Wgt	
7	6	14	5.25	3.5	2.75	5	6.63	0.34	6.5	99	99

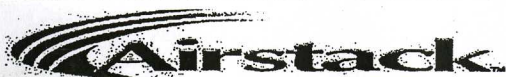

JOB NAME USO - Lick Observatory ENGINEER _____
 LOCATION _____ ARCHITECT _____
 CUSTOMER _____ CONTRACTOR _____

Multistack Order Number _____ Submitted by Kurt Wessels / S.D.
 Customer P.O. Number _____ Approved by _____
 Sales Representative Kurt Wessels Approval Date _____

Total Number of Modules: 2.0
 Overall Height(in): 77 Width: 31 1/2 Length: 119 3/4 (Dimensions Do Not Include J-Boxes)

CHILLED WATER DESIGN

Master Module ASP-15A (MF) 1
 Slave Front ASP-__A (SF) 0
 Slave Front ASP-__A (SF) 0
 Slave Rear ASP-__A (SR) 0
 Slave Rear ASP-__A (SR) 0

Chilled Water: 22 % Ethylene Glycol
 Entering Temperature 33.0 °F
 Leaving Temperature 24.0 °F
 Flow Rate 26.5 GPM
 Evaporator ΔP 2.9 Feet

AMBIENT AIR TEMPERATURE

Design: 95.0 °F
 Low: 0.0 °F

FULL LOAD CHILLER PERFORMANCE

Cooling Capacity: 8.7 Tons
 Power Input: 15.7 KW
 EER: 6.6

FREE COOL DESIGN

Free Cool Front ASP-00F (FF) N/A
 Free Cool Rear ASP-00F (FR) N/A
 Chilled Water:
 Entering Temp N/A °F
 Leaving Temp N/A °F
 Flow Rate (each) N/A GPM
 Total Flow Rate N/A GPM
 Operating ΔP N/A Feet
 Bypass ΔP N/A Feet

ACCESSORY MODULES

180 Gallon Tank Module(s) ASP-00T 0
 Glycol Feeder Module(s) ASP-00G 0
 Pump Module(s) ASP-00P 1

PUMP DESIGN

Pump Size (2) 1.5x1x8
 Flow Rate 26.5 GPM
 Pump 3 hp
 Total Head 52.0 Feet
 Assumes 49.1 ft of external head

CHILLER FEATURES

- Stainless Steel Evaporator
- Lead Compressor Sequencing (24hrs)
- Automatic Internal Rescheduling If Fault Occurs
- Automatic Logging Of Any Fault Condition
- Electronic Chilled Water Control
- Multiple Independent Ref. Systems
- Quick Interconnect Modular Design
- Aluminum Fin/Copper Tube
- Condenser Coils
- Dual Condenser Fans Per Module
- Designed For Quiet Operation
- Pressure Controlled 1140 RPM Fan Motors
- Filters In Evaporator Supply Headers
- R-407c Refrigerant
- 5 Year Compressor Warranty
- Single Point Power
- Expansion Tank In Pump Module
- (2) Independent Refrigerant Circuits per Module
- 5 Year Parts Warranty
- Discharge & Suction Gauges

ELECTRICAL DATA

MAIN POWER SUPPLY 230 / 60 / 3

FANS: 4 FLA per fan motor

ELECTRICAL CIRCUIT(S) CAPACITY

CHILLER CIRCUIT*

Minimum Circuit Ampacity (amps) 70
 Maximum Fuse Size (amps) 93
 Recommended Dual Element Fuse 100

ASP-15A: 23.2 RLA per compressor

ASP-00P: 9.6 FLA per module

*All chillers require completion of at least one of these columns.

** Compressor RLA's are obtained at ARI Conditions

First Letter

- M=Master Chiller Module
- S=Slave Chiller Module
- P=Pump Module
- F=Free Cool Module
- G=Glycol Feeder Module

Second Letter

- F=Front Module
- R=Rear Module

CHILLER LAYOUT



IMPORTANT: To assure full equipment design performance, life and reliability, the MULTISTACK chiller must be piped in accordance with Installation Manual unless specifically authorized otherwise by MULTISTACK in writing.

AIR COOLED PACKAGED CHILLER

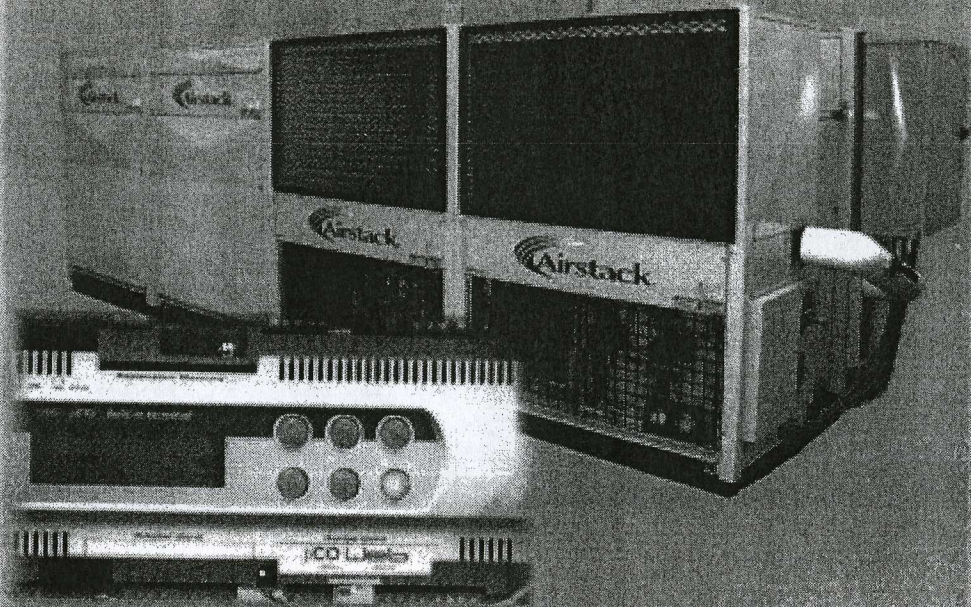

MASTER CONTROLLER

PCO² CONTROLLER USER MANUAL

CONTROLLER FOR "ASP-2C"
AIR-COOLED PACKAGED CHILLER
for Version - MCAS_G07, MCAL_G07, MCAB_G07
2 Refrigerant Circuits in 1 Module - Networked



MFG BY AIRSTACK, A DIVISION OF MULTISTACK®

Introduction

An Airstack Air-cooled Packaged Chiller-2 Circuit (ASP-2C) is a modular air-cooled chiller, composed of one or more modules, to provide chilled liquid to an external circuit. These *mechanical cooling* modules interconnect through a common chilled water header system. Each module contains 2 scroll compressors, a stainless steel, dual circuit, brazed plate heat exchanger, copper tube with copper condenser coils, two fans, and other related control components. There are two independent refrigerant circuits in each ASP-2C module. The chiller is operated by a microprocessor based controller that monitors the status of each refrigerant circuit and provides a signal to operate compressors and fans as required. The chiller uses the entering chilled water temperature (ECHWT) and system setpoints to determine the need for cooling to the external circuit.

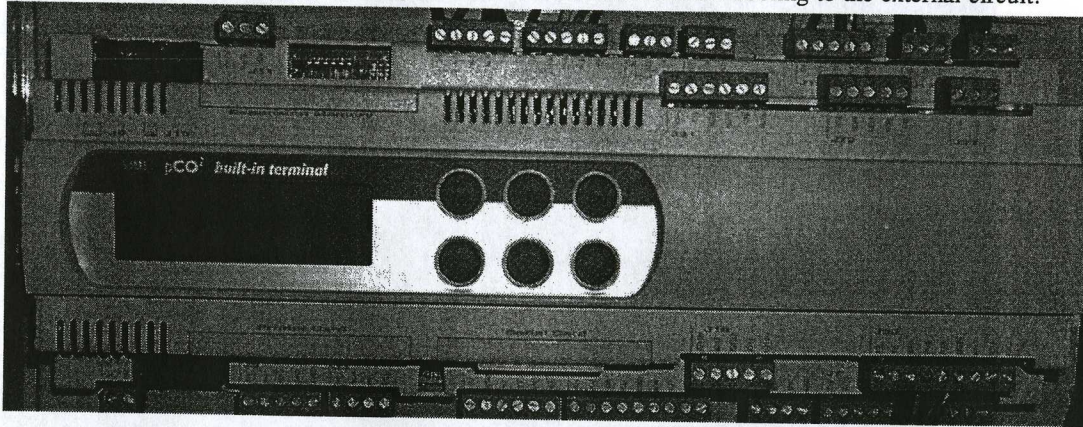

Figure 1 - pCO2 Master Controller

Master Controller

The *master controller* is equipped with a 4x20 character LCD with backlight and a six button keypad. These aid the operator in setting *SYSTEM VARIABLES*, checking faults, monitoring the status of the chiller. The *master controller* is also the interface to field supplied remote connections such as Remote Start/Stop, Flow Switch inputs, Customer Alarm outputs, and CHILLED WATER or LOAD LIMIT RESET signals. There is also an optional communication link for remote monitoring and control of the chiller system. Each *master controller* can control up to 8 modules.

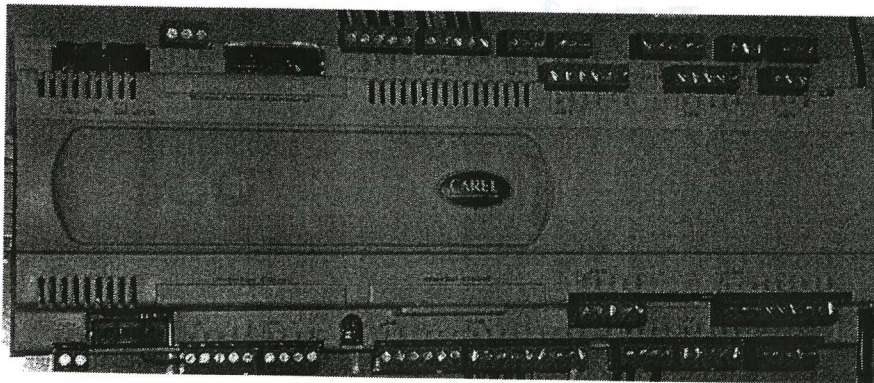





Figure 2 - pCO2 Module Board

Module Board

Each module has a *module board*, which sends information to the *master controller* regarding the temperatures, pressures, and activity of the module. The feedback from the *module board* determines the status of its circuits. The *module board* performs safety checks and alerts the *master controller* when something is wrong. Loss of communication with the *master controller* results in the shutting down of the module, unless the module is running in *manual mode*. The inputs and outputs for the first module in the chiller are integrated into the *master controller* board.

Controller Keys

On the master controller, there are six buttons to assist the user in navigating the screens of the controller. The following information describes the use of each button.

-  The **UP** arrow button is used to go back to the previous category on the screen or to increase the value of a digit in a numeric variable field.
-  The **DOWN** arrow button is used to advance to the next category on the screen or to decrease the value of a digit in a numeric variable field.
-  The **ENTER** button is used to make a selection from any of the menu screens in the program. It is also used to enter and exit *edit mode* while in the *SYSTEM VARIABLES* screens.
-  The **ALARM** button is the menu for current system or module faults. When the backlight is red, it indicates that a fault has occurred.

Prg The **PROGRAM** button goes to the *MAIN MENU* from any screen in the program.

Esc The **ESCAPE** button goes to the previous screen or the *main status screen*, if you are at the top of the *MAIN MENU*.

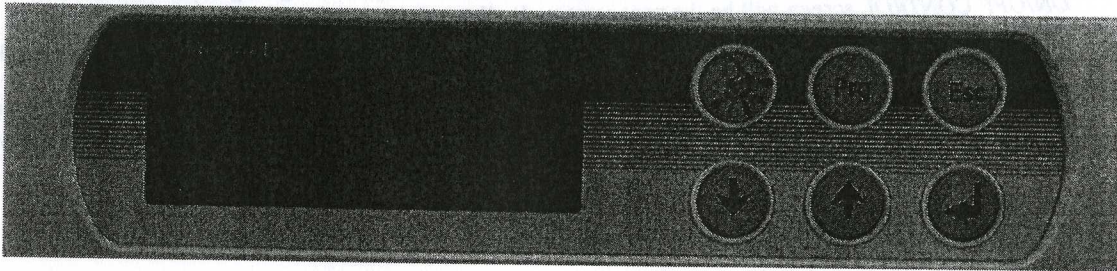

Controller Setup

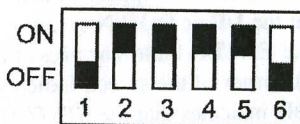

On each controller, master or module board, there is a set of six DIP switches. These switches define the network of the chiller system and identify each module in the system. The DIP switches are set in binary code addressing, where the first switch is a value of 1, the second is a value of 2, the third is a value of 4, the fourth is a value of 8, the fifth is a value of 16, and the sixth is a value of 32. The following DIP switch would give an address of 30 to its controller. (The black square is the switch position.)



= 30

Switches	ON	Value
2	=	2
3	=	4
4	=	8
5	=	16
		<u>30</u>

The following are the addressing parameters for setting up an ASP chiller network:

-  Mechanical Cooling Addresses – 2 thru 8
-  Master Controller Address – 30
-  Remote LCD Display – 32

In setting up the network, the *master controller* must have an address of 30. The first *mechanical cooling* module is integrated into the *master controller* board. The second *mechanical cooling* module would be 2, the next 3 and so on. For more help in DIP switch settings, see Appendix A on page 18.

Manual/Off/Auto Switch

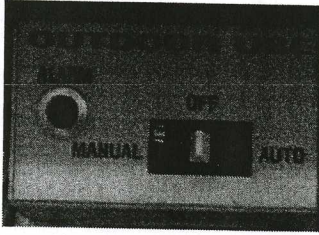

Each *mechanical cooling* module has a *Manual/Off/Auto* switch. In *manual mode*, the staging of the compressors is done by its module board. The control is independent of the other modules and is based on the LCHW of that module. When *auto mode* is selected, the staging of the compressors is handled by the *master controller*. The *master controller* will determine how many compressors need to be on to satisfy the load requirements. Control of the compressors is based on the system ECHW when in *auto mode*.

Disabled mode (off) selection disables the module and the compressors are not allowed to run. However, the fans will still cycle on and off based on the high pressure in that module.

Main Menu

The *MAIN MENU* displays the options the user can access in the program. Press the **Prg** button to get to the *MAIN MENU* and then use the **UP** and **DOWN** arrow buttons to scroll through the menu. The **ENTER** button allows displaying of the sub-menu that the greater than sign (>) is located beside. The *MAIN MENU* contains *ON/OFF CONTROL*, *STATUS*, *SYSTEM VARIABLES*, *FAULT REVIEW*, *LOAD PROFILE*, and *SECURITY*.

On/Off Control Screen

Upon power up, the initial screen will go through a 12 second delay before giving control to the user. The *ON/OFF CONTROL* screen will be the next screen. It allows the user to command the chiller on or off. The display will read 'CHILLER OFF, PUSH ENTER TO START'. Pushing the **ENTER** button, will display a message of '30 SECONDS TO START!' and will change to 'CHILLER ON, PUSH ENTER TO STOP'. After the 30 second delay, the display will change to the *main status screen* and the lead compressor will turn on, if needed. The last line of the screen shows any critical system faults such as *WAITING FOR CHW FLOW* and *REMOTE START/STOP*.

System Variables

Once power is connected to the *master controller*, the *SYSTEM VARIABLES* can be accessed. These variables determine how the chiller system will run and are assigned default values. For most installations, these values will provide optimum performance. However, special operating conditions may require different settings.

Use the **UP** or **DOWN** arrow buttons to locate the *SYSTEM VARIABLES* in the *MAIN MENU*. The greater than sign (>) is the cursor indicator. Press the **ENTER** button to enter the *SYSTEM VARIABLES' MENU*. Press the **ENTER** button again to enter one of the sub-menus. The *SYSTEM VARIABLES' MENU* includes *MECHANICAL COOLING*, *CUSTOMER RESETS*, *TEMPERATURE READINGS*, and *TIME AND DATE*.

To change the value of a variable, press the **ENTER** button. A blinking block cursor will appear in that system variables' value field indicating that the program is in *edit mode*. Use the **UP** or **DOWN** arrow buttons to change the value of the variable. To save the new setting, press the **ENTER** button or press the **Esc** button to cancel the change. The cursor will move back to the upper left corner of the screen indicating that the program is no longer in *edit mode*. An asterisk (*) next to the variable indicates that the *SYSTEM VARIABLES* are **locked** and cannot be adjusted. For assistance on unlocking the *SYSTEM VARIABLES*, see *SECURITY* on page 14.

Mechanical Cooling System Variables

The following is a list of *SYSTEM VARIABLES* for the *mechanical cooling* modules:

1. **UPPER SETPOINT:** The entering chilled water temperature (ECHW) at *full load*. When the water entering the chiller is at or above this setpoint, all available compressors should be running.

2. **LOWER SETPOINT:** The leaving chilled water temperature (LCHW – System sensor) at *full load*. The temperature drop across this chiller is based on flow rate. If the design temperature drop (ΔT) is 10°F across the chiller, then the LOWER SETPOINT should be 10°F below the UPPER SETPOINT.
3. **VSP SETPOINT:** A percentage used to determine the *no load* chilled water temperature. If the UPPER SETPOINT is at 55°F, the LOWER SETPOINT is at 45°F, and the VSP is at 50%, then the *no load* point would be 50% of the difference between the UPPER SETPOINT and the LOWER SETPOINT settings, which is 5°F. Therefore, all compressors would be on a 55°F and all compressors would be off at 50°F by the temperature of the ECHW Sensor.
4. **LOAD LIMIT:** A percentage used to limit the maximum system load.
5. **T-DIFF (Time Difference):** The minimum time in seconds between starts and stops of compressors. This time should be set to the loop time. The loop time is the time it takes for the water to make one pass through the entire CHW loop of the building.
6. **FAIL INDIC (Failure Indicator):** A percentage value which provides for an output signal whenever compressors of the indicated value have failed. A 0% setting will give an output signal after any failure within the system.
7. **LEAD COMP:** Determines which compressor is the first on and the last off. The compressors will appear in a format of M1-1, M1-2, M2-1, etc. This format stands for Module #1 –Compressor #1 and so on.
8. **MAN. SETPOINT:** Please see page 8 on *manual mode* operation for further details.
9. **MAN. RANGE:** Please see page 8 on *manual mode* operation for further details.
10. **MAN. OFFSET:** Please see page 8 on *manual mode* operation for further details.
11. **NUM OF MODULES:** This is the number of *mechanical cooling* modules that are in the chiller system.
12. **FAN SETPOINT:** The point, measured in psig, where the last fan turns off.
13. **FAN OFFSET:** The value, measured in psig, when added to the FAN SETPOINT where the first fan turns on. When psig reaches 2 times the FAN OFFSET, the second fan will turn on. **Ex.** If the FAN SETPOINT is at 235 psig and the FAN OFFSET is at 30 psig, the first fan will come on at 265 psig and the second at 295 psig. They will then turn off at 265 psig and 235 psig.
14. **HP CUTOUT:** The point where a high pressure fault occurs based on the high pressure transducer.
Note: Each refrigerant circuit also has a mechanical high pressure switch with a manual reset. If this setting is set higher than the switch setting, the mechanical switch will take the compressor offline with a high pressure fault.
15. **SEQUENCE:** Determines the order for loading and unloading the compressors.
STANDARD – The compressors turn on in numerical order starting with the lead compressor.
ODD/EVEN – A scheme developed to bring one compressor in each module on before the second compressor in any module is allowed to run. If the LEAD COMPRESSOR ends in -2 (M1-2, M2-2, etc), then all even compressors would start before the odd compressors. If the LEAD COMPRESSOR ends in -1 (M1-1, M2-1, etc), then all odd compressors would start before the even compressors. See Appendix D on page 23 for more information on compressor rotations.
16. **INDEXING:** The indexing can either be ON or OFF. If ON, the lead compressor changes every 24 hours at midnight. If OFF, the LEAD COMPRESSOR stays the same and will have the most runtime. See Appendix D on page 23 for more information on compressor rotations.

Standard Application

System Variable Ranges & Default Settings

Mechanical Cooling

The following table defines all of the *SYSTEM VARIABLE* ranges and default values for *mechanical cooling* modules.

System Variable	Range	Default Value
UPPER SETPOINT	45°F to 80°F	55°F
LOWER SETPOINT	40°F to 70°F	45°F
VSP VALUE	0% to 80%	50%
LOAD LIMIT	0% to 100%	100%
T-DIFF	15 to 200 sec	90 sec
FAIL INDIC	0% to 90%	0%
LEAD COMP.	M1-1 to M14-2	M1-1
NUM OF MODULES	1 to 14	1
FAN SETPT.	170 to 350 psig	200 psig
FAN OFFSET	20 to 60 psig	30 psig
HP CUTOUT	300 to 425 psig	365 psig
SEQUENCE	STANDARD or ODD/EVEN	STANDARD
INDEXING	OFF or ON	ON

Standard Module Cutouts and Reset Points

Low Suction Temp	Cutout → 25°F	Reset @ 30°F
Low Leaving CHW	Cutout → 36°F	Reset @ 40°F
Low Pressure	Cutout → 15 psig	Reset @ 30 psig

Mechanical Cooling (Auto Mode)

The following chart defines how the chiller works in *auto mode*. It is based on a 10 compressor system (5 modules) with a 10°F ΔT, and operation between 55°F and 45°F. It shows the system relationship between ECHWT, LCHWT, and VSP at various load conditions.

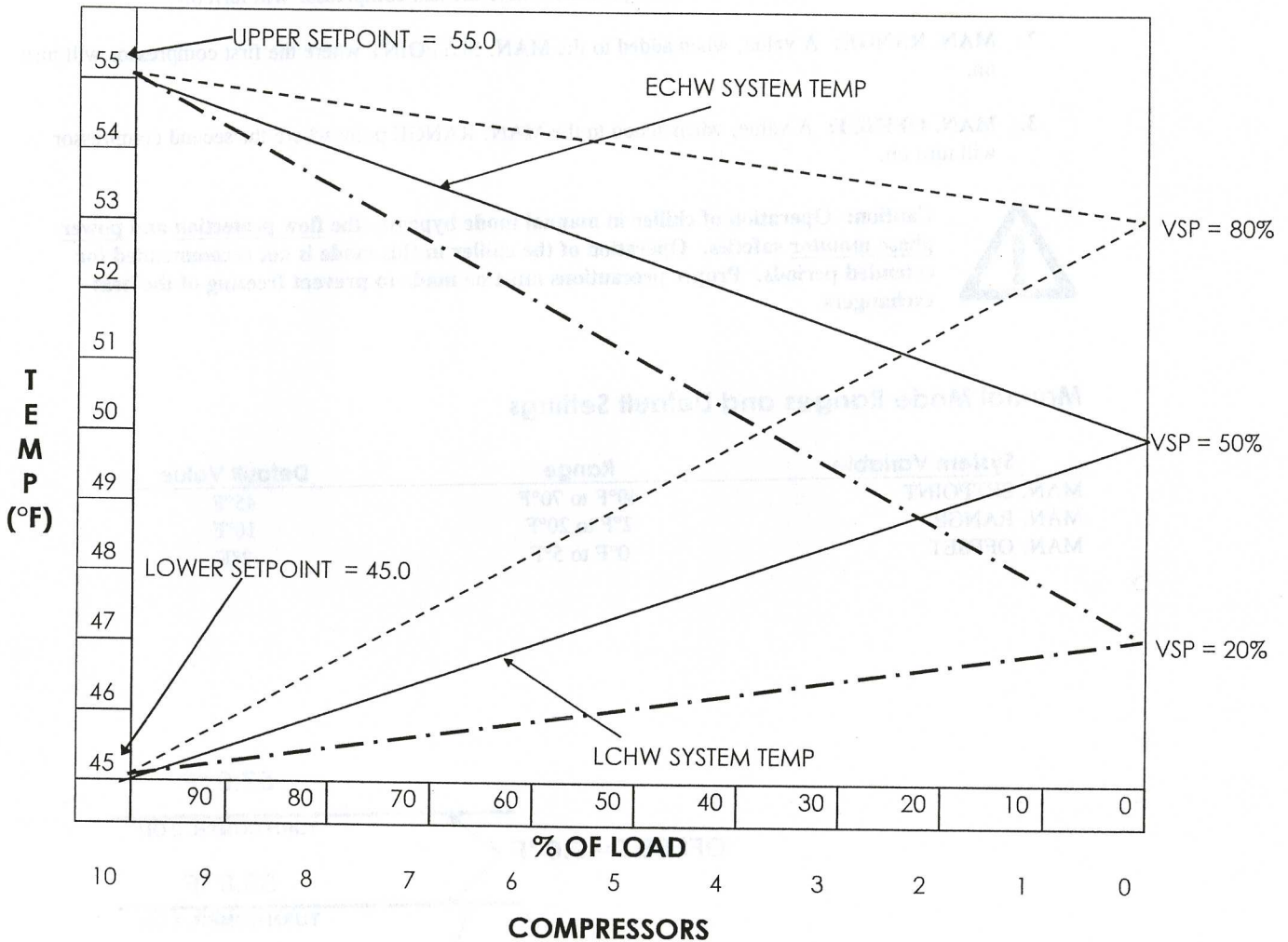

System Conditions: Full Load ΔT = 10 °F UPPER SETPOINT - 55 °F
 10 Compressors LOWER SETPOINT - 45 °F

The data below shows same operating conditions that could occur based on the information from the chart

VSP = 20 %			VSP = 50 %			VSP = 80 %		
% LOAD	ECHWT	LCHWT	% LOAD	ECHWT	LCHWT	% LOAD	ECHWT	LCHWT
0	47	47	0	50	50	0	53	53
50	51	46	50	52.5	47.5	50	54	49
100	55	45	100	55	45	100	55	45

Mechanical Cooling – Manual Mode

In *manual mode* operation, each module acts independently, depending on the sensor inputs to that module. The staging of the compressors is done by its module board. The control is based on the LCHW temperature of that module. The following are *SYSTEM VARIABLES* that are used in *manual mode* operation:

1. **MAN. SETPOINT:** The LCHW temperature where the last compressor will turn off.
2. **MAN. RANGE:** A value, when added to the MAN. SETPOINT where the first compressor will turn on.
3. **MAN. OFFSET:** A value, when added to the MAN. RANGE point where the second compressor will turn on.



Caution: Operation of chiller in manual mode bypasses the flow protection and power phase monitor safeties. Operation of the chiller in this mode is not recommended for extended periods. Proper precautions must be made to prevent freezing of the heat exchangers.

Manual Mode Ranges and Default Settings

System Variable	Range	Default Value
MAN. SETPOINT	40°F to 70°F	45°F
MAN. RANGE	2°F to 20°F	10°F
MAN. OFFSET	0°F to 5°F	2°F

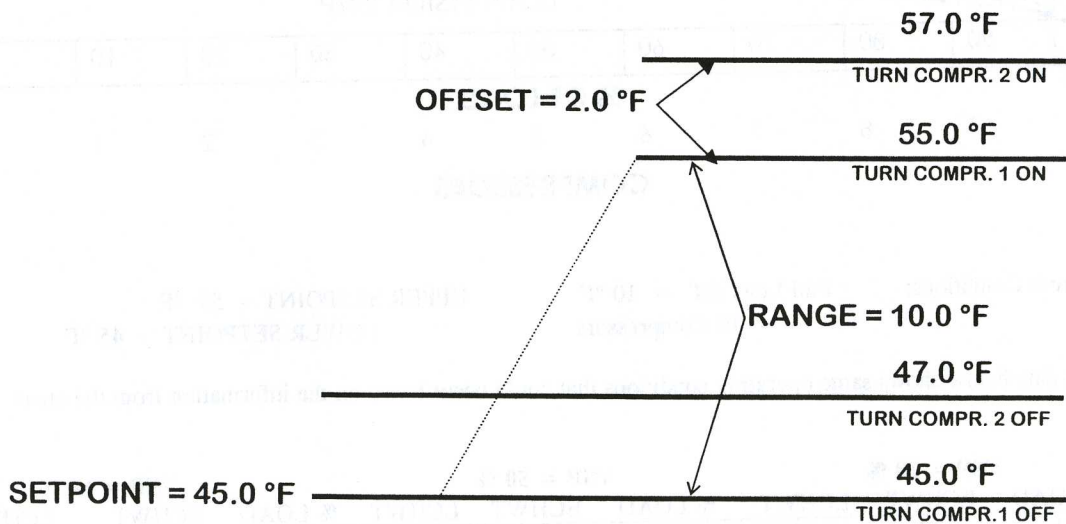

Master Controller Status Screens

System Screens

The *main status screen* displays information about the chiller.

1. **CAPACITY:** A percentage of how many compressors are turned on, compared to the total installed. An asterisk (*) displayed next to capacity indicates that it is being controlled by an external source, either **LOAD LIMIT** or **CHILLED WATER RESET**.
2. **DEMAND:** A percentage of current load needed compared to the maximum design load. This value is determined by the system **ECHW** temperature and the settings of the *SYSTEM VARIABLES*.
3. **DELAY:** A time in seconds between starts or stops up of compressors. A compressor should only turn on or off if the delay time counter is at zero. This is determined by the *mechanical cooling* module's system variable **T-DIFF**.
4. **FAULTS:** A value showing the number of current or resettable faults that are in the chiller.
5. **ECHW:** The Entering Chilled Water temperature of the chiller. (Return Water from the building.)
6. **LCHW:** The Leaving Chilled Water temperature of the chiller. (Supply Water to the building.)

Press the **DOWN** arrow button once to display the next *status screen* with system information.

1. **LEAD COMP:** The compressor shown is the first on and the last off.
2. **LOAD LIMIT:** A percentage value to limit the max number of compressors available at any given time. An asterisk (*) indicates that an external **LOAD LIMIT RESET** signal is enabled.
3. **CHW OFFSET:** Shows value of customer **CHW RESET** signal. Range 0 to 10°F. An asterisk (*) indicates the external **CHW RESET** signal is enabled.

Mechanical Cooling Screens

Press the **DOWN** arrow button again to display information for the first module. The following information is available:

1. **LCHW:** The leaving chilled water temperature in the module.
2. **COMP1** and **COMP2:** This displays the status of the compressors, **ON** or **OFF** in that module.
3. **FAN1** and **FAN2:** Displays the status of the fans, **ON** or **OFF**. **FAN 2** always turns on first.
4. **Status Line:** The status line of the module can be the mode in which the module is in or it can be what the current fault is on that module. If nothing appears in the status portion of the screen, then the module is in *auto mode* and there are no faults. If **MANUAL MODE** or **DISABLED** appears on the status line, then the module is in *manual mode* or *disabled*. The faults that occur on the modular level will also be displayed on the status line when the fault is current.

Press the **ENTER** button to display information for compressor circuit #1 of module 1.

1. **COMP1:** This displays the status of the compressors, **ON** or **OFF** in that module.
2. **SUCT:** The suction temperature in the refrigerant circuit measured on the compressor suction line.
3. **HP:** The high side pressure of the refrigerant circuit measured in psig.
4. **LP:** The low side pressure of the refrigerant circuit measured in psig.

5. **HOURS:** The total number of hours the compressor has run. To reset the run hours of a compressor, press and hold the **ALARM** and **DOWN** arrow buttons simultaneously on the screen of the compressor whose hours need to be reset.
6. **Status Line:** The status line of the module can be the mode in which the module is in or it can be what the current fault is on that module. If nothing appears in the status portion of the screen, then the module is in *auto mode* and there are no faults. If **MANUAL MODE** or **DISABLED** appears on the status line, then the module is in *manual mode* or *disabled mode*. The faults that occur on the modular level will also be displayed on the status line when the fault is current.

Press the **ENTER** button to display information for compressor circuit #2 of module 1.

Press the **ESC** button to go back to the Module 1 Status Screen.

Press the **DOWN** arrow button to go to the Module 2 Status Screen. Repeat the above steps to view the detailed information for module 2 and further modules.

Inputs and Outputs

Inputs - Analog

1. **High Pressure Transducers:** A 4-20 mA input sensor that measures the high side pressure of the refrigerant in a refrigerant circuit. There is one HP transducer for each refrigerant circuit.
2. **Low Pressure Transducers:** A 4-20 mA input sensor that measures the low side pressure of the refrigerant in a refrigerant circuit. There is one LP transducer for each refrigerant circuit.
3. **Leaving Chilled Water Sensor:** NTC type sensors that measure the temperature of each module's LCHW coming from the each *mechanical cooling* module.
4. **System Entering Chilled Water Sensor:** A NTC type sensor that measures the temperature of the ECHW going to the *mechanical cooling* modules from the building.
5. **System Leaving Chilled Water Sensor:** NTC type sensors that measure the temperature of the chiller's LCHW coming from the *mechanical cooling* modules to the building.
6. **Suction Sensors:** NTC type sensors that measure the temperature of the suction line in each refrigerant circuit. There is one suction sensor for each refrigerant circuit.
7. **Customer Reset Signal:** A 0-10Volt, 0-20 mA, or 4-20 mA, customer supplied, **external** signal that shifts the UPPER and LOWER SETPOINTS from 0 to 10°F or changes the LOAD LIMIT from 0 to 100%.

Inputs – Digital

1. **EX1:** A customer supplied input that is a closed circuit to operate; open to stop operation. Requires manual reset to resume operation. This input will create a fault.
2. **Remote Start/Stop:** An input that is a closed circuit to operate; open to stop operation. Automatic restart of the chiller. This input does **NOT** create a fault.
3. **Power Phase Monitor:** An input that is a closed circuit to operate; open to stop operation. Automatic restart returns the chiller to the previous on/off state of the chiller.
4. **CHW Flow Switch:** An input that is a closed circuit to operate; open to stop operation. Circuit opens when there is **NO FLOW**. After 4 seconds, the chiller shuts down. When the flow switch closes, the chiller will automatically restart.
5. **High Pressure Switch:** An input that indicates when the switch for the high side pressure of a refrigerant circuit has tripped. There is one HP switch for each refrigerant circuit.

6. **Circuit Faults:** An input that monitors the control circuit of each compressor for abnormal operating conditions. A 1 or 2 would be displayed to show which compressor circuit has a fault.
7. **Manual Mode/Auto Mode:** Inputs from the Manual/OFF/Auto Switch that tell the module board which mode of operation to run that module in.

Outputs – Digital

1. **Compressor Start Signal:** A 24V output to start the compressors.
2. **Fan Start Signal:** A 24V output to start the fans.
3. **Liquid Line Solenoid Valve:** A 24V output to energize the liquid line solenoid valves.
4. **Alarm Light:** A 24V output which indicates that there is an alarm on the module.
5. **Remote Pump Enable:** This is a 24V AC, 5VA max signal that can be used to remotely enable the pump. The signal will be high anytime the chiller is on. When the chiller is turned off, the pump will continue to run for two times the amount of time of TDIFF. The exception is when the Power Phase Monitor is tripped; the pump signal goes to low with no time delay.
6. **Run Status Relay:** A 24V output which indicates that at least one compressor is running.
7. **Customer Alarm Relay:** This is a 24V AC, 5VA max signal that can power a relay to trigger an alarm.
8. **Full Load Indicator Relay:** This is a 24V AC, 5VA max signal that can power a relay to show that the chiller system is at *full load* (all compressors on).

Faults

If a fault has occurred, the **ALARM** button will illuminate. To view the current fault(s), press the **ALARM** button. Use the **UP** and **DOWN** arrow and **ENTER** buttons to view and clear the fault(s). If the fault returns, then it will need to be reset elsewhere first.

Chiller Faults

If any of the following faults occur, all modules in the chiller will be disabled.

1. **EX1:** Customer Input – EX1 requires a reset and restart command at the *master controller*.
2. **REMOTE START/STOP:** Customer Input – This is NOT a true fault. This circuit operates like an on/off switch. If closed, the chiller is on, as long as the chiller has been commanded on. If open, the chiller is disabled and the compressors will not run. When this input is closed then opened and then closed again, the chiller will start.
3. **POWER PHASE:** This fault alerts the customer of a disruption in power. There is no reset required at the *master controller*. If the chiller is on when fault occurs, it will default back to *on* after the fault clears.
4. **CHW Flow:** This alerts the *master controller* of NO FLOW in the chiller and disables all modules. There is an automatic restart after the flow switch closes.
5. **ECHW Sensor Failure:** The sensor for the system ECHW has either opened or shorted to the *master controller*. This fault requires resetting at the *master controller*.
6. **LCHW Sensor Failure:** The sensor for the system LCHW has either opened or shorted to the *master controller*. This fault requires resetting at the *master controller*.
7. **System LOCHW Temp:** Low Leaving Chilled Water temperature. If the LCHW of the system falls below 36°F, the compressor will turn off. The water temperature must rise to 40°F before the fault can change from current to reset. This requires resetting the fault at the *master controller* and restarting the chiller.

Individual Compressor Faults

1. **High Pressure:** High Pressure Cutout. This high pressure fault can come from either the transducer reading or the HP switch being tripped. If the HP transducer reaches the pressure of the **HP Cutout** variable the alarm goes off, shutting down that module. In this case, the fault only needs to be reset at the *master controller* after the high side pressure drops below 300 psig. If the HP switch trips then, it requires resetting at the module HP switch and the *master controller* to resume operation. The fault will remain current until the HP switch is manually reset.
2. **HP Sensor Failure:** The High Pressure Transducer has either opened or shorted to the *master controller*. This fault requires resetting at the *master controller*.
3. **Low Pressure:** Low Pressure Cutout. If the reading from the LP transducer falls below 15 psig, then that module will be shut down and in an alarm state. This fault will remain current until the low side pressure rises above 25 psig. The fault can then be reset at the *master controller*. (Typically indicates loss of refrigerant charge.)
4. **LP Sensor Failure:** The Low Pressure Transducer has either opened or shorted to the *master controller*. This fault requires resetting at the *master controller*.

5. **Low Pressure Delay:** Occurs when the low side pressure drops below 25 psig disabling the compressor in that circuit for 5 minutes. It automatically resets after the 5 minutes, as long as the low side pressure reading is above 30 psig. The compressor will be allowed to run for 1 minute between 15 and 25 psig, before being shut down, upon start of the compressor.
6. **LOCHW Temp:** Low Leaving Chilled Water temperature. If the LCHW of the circuit falls below 36°F, the compressor will turn off. The water temperature must rise to 40°F before the fault can change from current to reset. This requires resetting the fault at the *master controller*.
7. **LCHW Sensor Failure:** The sensor for each circuit's LCHW has either opened or shorted to the *master controller*. This fault requires resetting at the *master controller*.
8. **Circuit Fault:** A CIRCUIT FAULT will occur if the compressor contactor is not operating normally. Three conditions could potentially create a CIRCUIT FAULT. One would be, if the program signals for a contactor to be closed and it does not close within 5 seconds. Once the contactor has been closed for 5 seconds, if the contactor ever opens for 1 second while under normal operating conditions (indicating a chattering contactor), a fault will occur. The third condition would be if the program turns a contactor off and the contactor remains closed for an additional 10 seconds, this fault would occur (indicating a welded contactor). The fourth way to get a circuit fault would be if the difference between the high pressure and the low pressure in the circuit is not at least 50 psi with in 60 seconds. This fault requires resetting at the *master controller* to resume normal operation.
9. **LOSUCT:** Low Suction Temperature: This is measured by the circuit suction sensor and would affect that circuit only. If during operation this temperature should drop below 25°F, that circuit's compressor will shut down. This requires resetting at the *master controller*, but only after the temperature has risen above 30°F.
10. **SUCT SENSOR FAILURE:** Suction Sensor Failure. This would occur if the suction line sensor opened or shorted to the *master controller*. This fault requires resetting at the *master controller*.
11. **COMMUNICATION ERROR:** This would occur if more than one module is addressed the same, or if there is a problem with communications of that individual module to the *master controller*. This fault only occurs in *auto mode*.

Fault Review

The **FAULT REVIEW** is a history of the faults that have occurred in the chiller system. The review holds up to 25 faults. The review can be found in the *MAIN MENU*. The faults are in order by the most recent to the oldest. Pushing the **UP** and **DOWN** arrow buttons allows scrolling through the faults. Pushing the **ENTER** button on a particular fault allows for viewing of a second screen of information. Pushing **ENTER** again returns to the first screen of the fault. The following is a sample of what the two screens contain.

FAULT 01	CURRENT
COMMUNICATION ERROR	
MOD1	9/17 12:35
PRESS ENTER FOR MORE	

Screen #1

FAULT 01	SUCT 00.0
*SYSTEM	LCHW 00.0
*ECHW 00.0	HP = 000
*LCHW 00.0	LP = 000

Screen #2

Screen one displays information about the fault. The status of the fault will be displayed as **CURRENT**, **RESET**, or **RECORD**. **CURRENT** means that the fault is still present, **RESET** means that the fault can be reset at the *master controller*, and **RECORD** means that the fault is part of the history for future reference. The date and time of the fault, the fault that occurred and where the fault occurred are also displayed on the first screen. On screen two, the system temperatures at the time the fault occurred will be displayed on the left side of the screen and are starred with an asterisk (*). On the right side of the screen is module information that was current at the time of the fault. If the fault is a system fault the module information will display all zeros.

Clearing the faults from the **FAULT REVIEW** removes all the faults at once. Hold down the **Prg** and **UP** arrow buttons simultaneously for all faults to be removed from the **FAULT REVIEW**. When a message of **NO MORE ALARMS** appears on the screen, release the buttons.

Load Profile

The **LOAD PROFILE** displays the operating history of the *mechanical cooling* modules. It relates the total operating hours to the load percent and is subdivided into 10% segments. This screen is located in the *MAIN MENU* of the *master controller*. There are three screens used to display the information. Pressing the **DOWN** arrow button will allow all screens to be viewed. To reset the hours in the **LOAD PROFILE**, hold down the **DOWN** arrow and the **ALARM** buttons simultaneously while viewing the **LOAD PROFILE**. The *SYSTEM VARIABLES* must be **unlocked** to clear the **LOAD PROFILE**.

Time and Date

The **TIME AND DATE** option is located in the *SYSTEM VARIABLES' MENU*. Press **ENTER** on the **TIME AND DATE** option. The time appears first and is displayed in military time. To change the time, press the **ENTER** button, putting the program into *edit mode*. The cursor is now in the *hour* field, use the **UP** and **DOWN** arrow buttons to change the *hour* to the correct time. Press the **ENTER** button again to move the cursor to the *minute* field to change it. Press the **ENTER** button one more time to set the **TIME**. Press the **Esc** button, at anytime, to abort the time change.

After setting the **TIME**, use the **DOWN** arrow button to move to the **DATE** screen. Press **ENTER** to move the cursor into the *month* field. Using the **UP** and **DOWN** arrow buttons, change the value to the current *month*. Press **ENTER** again to move the cursor to the *day* field, adjust the *day* accordingly. Press **ENTER** again to move to the *year* field, adjust the *year* accordingly. Press **ENTER** one more time to accept the **DATE**. Press the **Esc** button, at anytime, to abort the date change.

Temperature Readings

The temperature readings default to Fahrenheit (°F). The readings may be set to display in Celsius (°C), by going to the *SYSTEM VARIABLES' MENU*. Press **ENTER** on **TEMP. READINGS** option. Press **ENTER** again to move the cursor into the field. Use the **UP** or **DOWN** arrow button to change the field from Fahrenheit to Celsius. Press **ENTER** again to accept the change.

Customer Resets

CHILLED WATER RESET (CHW) and LOAD LIMIT RESET are external inputs that are program selectable as 0-10Volt, 0-20 mA, or 4-20 mA. The *CUSTOMER RESET* option is located in the *SYSTEM VARIABLES' MENU*. The customer can send a signal to change these values remotely. The CHW RESET will increase the SETPOINT in the *mechanical cooling* modules anywhere from 0 to 10 °F. The LOAD LIMIT RESET will allow the LOAD LIMIT of the *mechanical cooling* modules to be changed. There will be an asterisk (*) by the SETPOINT and the LOAD LIMIT values on the second *status screen*, if they are enabled. An asterisk (*) also appears next to CAPACITY on the *main status screen* when either reset is enabled. Press **ENTER** and use the **UP** and **DOWN** arrow buttons to choose which reset will be used. Press **ENTER** again to select the type of input provided. (0-10 Volt, 0-20 mA, or 4-20 mA) Both default to **DISABLED**, but when enabling the user must select the type of input being used. Press **ENTER** to accept the reset value.

Security

The security option in the *MAIN MENU* is used to lock the *SYSTEM VARIABLES*. The first screen tells whether the variables are **locked** or **unlocked**. Initially the screen will say 'SYSTEM VARIABLES UNLOCKED'. Press **ENTER** to change the status of the security. The cursor will be on the first letter of the password code. Enter a five letter password, using the **UP** and **DOWN** arrow buttons to change the letter and press **ENTER** to move to the next letter. After entering the last letter, the next screen is to accept the password or clear the password. Press **ENTER** again to set the password or **Esc** to clear the password. The screen will then display the status of the *SYSTEM VARIABLES* as **LOCKED**.

If the password is forgotten, please call your Multistack Service Representative at 608-786-3400.

Board LED's

Five LED's are present on each board, master and module. Two LED's are located at the bottom of the board, one yellow and one red. The yellow one indicates that the board is receiving power. The red one is an alarm LED that would indicate that something maybe wrong with the board internally. Three more LED's are located at the top of the board next to the DIP switches. These LED's indicate that the connection, address definition and pLan (network of the modules) are working correctly. The green and yellow LED's should be lit for the network to be working properly.

Program Version

The program version is found by going to the *MAIN MENU* and pressing the **UP** arrow and **PRG** buttons simultaneously. A screen will appear that displays the version of the program in the controllers and the month and year the program was developed. The version will appear in a format similar to MCAS_A01. When looking at the version, the forth position could vary between S, L, and B. The S stands for a Standard application, the L for a Low Ambient application, and the B for a Brine or Low Temperature application. This each of these programs may have different cutouts or temperature ranges available to the customer. The *SYSTEM VARIABLES* and cutouts are located on page 4. The cutouts for the Low Ambient and Low Temperature applications are found in Appendix B on page 18.

BAS Interface

The *master controller* is capable of tying into a building automation system. Modbus and BACnet are the two protocols that are currently available. First the *BAS INTERFACE* needs to be enabled. This is accomplished by going to the *SYSTEM VARIABLES Menu* and changing the enable point, under *BAS INTERFACE*, to *yes*. The enable defaults to *no*. This menu also has a variable to select which *Protocol* will be used. Select the appropriate *Protocol* for the job. BACnet is the default for this variable.

Modbus

Modbus requires that a RS485 card is installed into the pCO2 *Master Controller*. This card plugs into the serial port and communicates Modicon Modbus Protocol Rev. D. The Modbus protocol used is RTU type. The configuration is multipoint for RS-485. The data communication is asynchronous serial, 8 data bits, 2 stop bits, and no parity across an EIA-485 two-wire half-duplex connection. The cable size recommended is an AWG20/22 two-wire twisted shielded cable. The pin wiring is GND, RX+/TX+, RX-/TX- and is stamped on the terminal connector. The customer can adjust the *Baud Rate* and the *Network Number*. These settings are found in the *SYSTEM VARIABLES Menu* under *BAS INTERFACE*. The *Baud Rate* defaults to 9600 bps and can be adjusted to 1200, 2400, 4800, 9600, or 19200 bps. The *Network Number* is the same as a slave address and defaults to 1. This number must be unique to the Modbus network. The range for the *Network Number* is from 1-200. See the ASP Modbus Technical Manual for a table of Modbus register points.

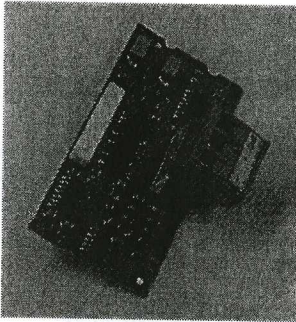

Figure 3 - RS485 Card

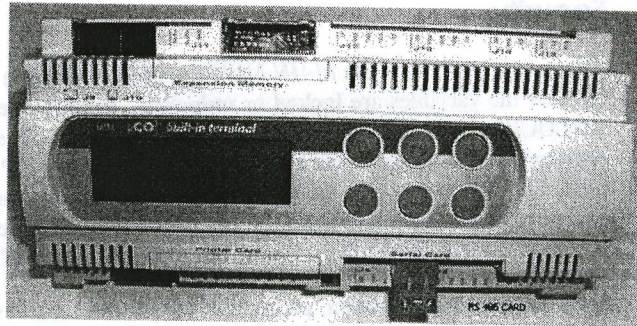

Figure 4 - pCO2 with RS485 Card

BACnet

BACnet requires that a pCO Web card is installed in to the pCO2 *Master Controller*. This card plugs into the serial port and communicates BACnet over Ethernet (ISO8802-2 or 8802-3) or BACnet over TCP/IP (Addenda A/Annex J). The recommended cable is shielded class 5, max 100mt. The *Baud Rate* is selectable and defaults to 19200. See the ASP BACnet Technical Manual for a table of points and instructions on changing the IP Addressing scheme.

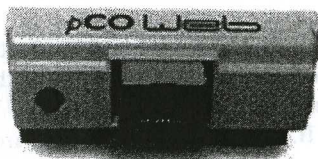

Figure 3 - pCO Web Card

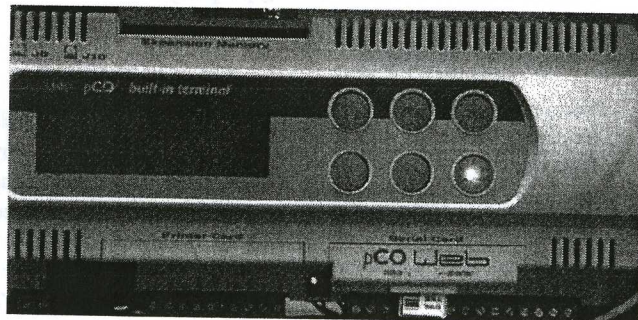
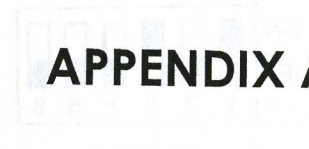
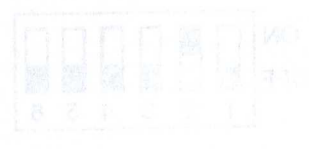

Figure 4 - pCO2 with pCO Web Card

The following table provides the DIP switch settings for the various modules. The table represents the factory default settings.

Macintosh Control Panel



APPENDIX A

DIPSWITCH SETUP

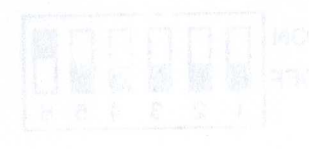

The following are the positions of the DIP switches to setup the network of ASP's. The black square represents the location of the switch.

Mechanical Cooling Modules

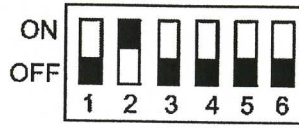

Module 2

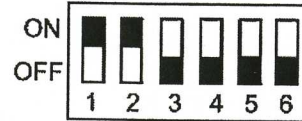

Module 3

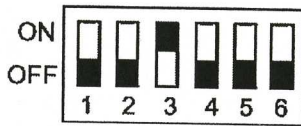

Module 4

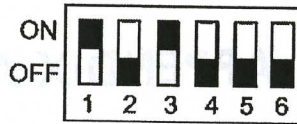

Module 5

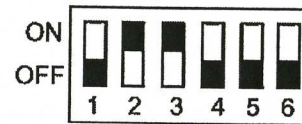

Module 6

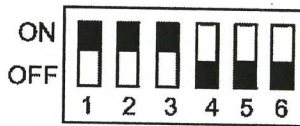

Module 7

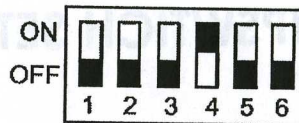

Module 8

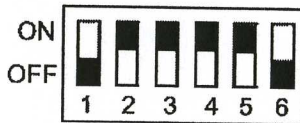

Master Controller
W/ Module 1

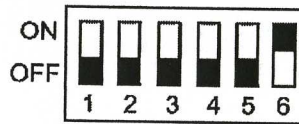

Remote Display

DEFINITION OF INPUTS
MODULE W/ TWO REFRIGERANT CIRCUITS
10.15-20 TON MODULES
VUTE3 LOGIC LARGE BOARD

APPENDIX B

DEFINITION OF INPUTS AND OUTPUTS

ANALOG INPUTS

81
82
83
84
85
86
87
88
89
90

DIGITAL INPUTS

ID1
ID2
ID3
ID4
ID5
ID6
ID7
ID8
ID9
ID10
ID11
ID12
ID13
ID14
ID15
ID16
ID17
ID18

DEFINITION OF INPUTS

MODULE w/ TWO REFRIGERANT CIRCUITS

10, 15, 20 TON MODULES

USES pCO2 LARGE BOARD

ANALOG INPUTS

J2	{	B1	HP TRANSDUCER CIRCUIT 1
		B2	LP TRANSDUCER CIRCUIT 1
		B3	MODULE LCHW SENSOR
J3	{	B4	<i>SYSTEM ECHW SENSOR*</i>
		B5	<i>SYSTEM LCHW SENSOR*</i>
		B6	HP TRANSDUCER CIRCUIT 2
J6	{	B7	LP TRANSDUCER CIRCUIT 2
		B8	<i>CUSTOMER RESET SIGNAL*</i>
		J20	{
B10	SUCTION TEMPERATURE SENSOR CIRCUIT 2		

DIGITAL INPUTS

J5	{	ID1	MANUAL MODE
		ID2	AUTO MODE
		ID3	
		ID4	HP SWITCH CIRCUIT 1
		ID5	HP SWITCH CIRCUIT 2
		ID6	CIRCUIT FAULT COMPRESSOR 1
		ID7	CIRCUIT FAULT COMPRESSOR 2
		ID8	
J7	{	ID9	<i>EX1 INPUT*</i>
		ID10	<i>REMOTE START/STOP*</i>
		ID11	<i>POWER PHASE MONITOR*</i>
		ID12	<i>CHILLED WATER FLOW SWITCH INPUT*</i>
		ID13	<i>PUMP #1 STATUS**</i>
		ID14	<i>PUMP #2 STATUS**</i>
		ID15	<i>LOW GLYCOL TANK LEVEL**</i>
		ID16	
		ID17	
		ID18	

* Entries that are bold and italic are only on a master controller board and deal with inputs for the chiller as a whole.

** Inputs that may not be used depending on the application of the chiller.

**DEFINITION OF OUTPUTS
MODULE w/ TWO REFRIGERANT CIRCUITS
10, 15, 20 TON MODULES
USES pCO2 LARGE BOARD**

ANALOG OUTPUTS

Y1
Y2
Y3
Y4
Y5
Y6

DIGITAL OUTPUTS (RELAY TYPE)

J12	{	NO1	COMPRESSOR #1 START SIGNAL
		NO2	
		NO3	LIQUID LINE SOLENOID VALVE CIRCUIT #1
J13	{	NO4	ALARM LIGHT
		NO5	FAN #1 START SIGNAL
		NO6	FAN #2 START SIGNAL
		NO7	REMOTE PUMP ENABLE *
J15	{	NO8	RUN STATUS *
		NC8	
J16	{	NO9	COMPRESSOR #2 START SIGNAL
		NO10	
		NO11	LIQUID LINE SOLENOID VALVE CIRCUIT #2
J17	{	NO12	CUSTOMER ALARM RELAY *
		NC12	
J18	{	NO13	FULL LOAD INDICATOR RELAY *
		NC13	
		NO14	
		NC14	
		NO15	
		NC15	
		NO16	
		NO17	
		NO18	

* Entries that are bold and italic are only on a master controller board and deal with outputs for the chiller as a whole.

DESCRIPTION OF OUTPUT
MODULE W/ TWO REFRIGERANT CIRCUITS
10, 18, 20 TON MODULES
USES PCO2 LARGE BOARD

ANALOG OUTPUT
Y1
Y2
Y3
Y4
Y5
Y6

APPENDIX C

SYSTEM VARIABLE RANGES & DEFAULTS FOR LOW AMBIENT APPLICATIONS & LOW TEMPERATURE APPLICATIONS

DIGITAL OUTPUT (RELAY TYPE)
NO1
NO2
NO3
NO4
NO5
NO6
NO7
NO8
NO9
NO10
NO11
NO12
NO13
NO14
NO15
NO16
NO17
NO18

LOW AMBIENT APPLICATION (Special Program Required)
 Program Version Format MCAL_A01

System Variable Ranges & Default Settings

Mechanical Cooling Modules

The following table defines all of the *SYSTEM VARIABLE* ranges and default values for *mechanical cooling* modules with a low temperature program.

System Variable	Range	Default Value
UPPER SETPOINT	45°F to 80°F	55°F
LOWER SETPOINT	40°F to 70°F	45°F
VSP VALUE	0% to 80%	50%
LOAD LIMIT	0% to 100%	100%
T-DIFF	15 to 200 sec	90 sec
FAIL INDIC	0% to 90%	0%
LEAD COMP	M1-1 to M14-2	M1-1
NUM OF MODULES	1 to 14	1
MAN. SETPOINT	40°F to 70°F	45°F
MAN. RANGE	2°F to 20°F	10°F
MAN. OFFSET	0°F to 5°F	2°F
FAN SETPT	170 to 350 psig	235 psig
FAN OFFSET	20 to 60 psig	30 psig
HP CUTOUT	300 to 425 psig	365 psig
SEQUENCE	STANDARD or ODD/EVEN	STANDARD
INDEXING	OFF or ON	ON

Module Cutouts and Reset Points

Low Suction Temp	Cutout → 20°F	Reset @ 25°F
Low Leaving CHW	Cutout → 36°F	Reset @ 40°F
Low Pressure	Cutout → 15 psig	Reset @ 30 psig

LOW SUCTION FAULT

The low suction fault in the low temperature and low ambient application works differently than in the standard program. One compressor in the module must be on for 30 seconds before a low suction fault can occur. This allows the suction line to increase its temperature on a cold start before receiving a fault. The chiller system must have Glycol in place in order to have the low temperature or low ambient program options available. This is measured by the module suction sensor and would affect the entire module. If during operation this temperature should drop below 20°F, the module's compressors will shut down. This requires resetting at the *master controller*, but only after the temperature has risen above 25°F.

LOW TEMPERATURE APPLICATION (Special Program Required)

Program Version Format MCAB_A01

System Variable Ranges & Default Settings

Mechanical Cooling Modules

The following table defines all of the *SYSTEM VARIABLE* ranges and default values for *mechanical cooling* modules with a low temperature program.

System Variable	Range	Default Value
UPPER SETPOINT	25°F to 80°F	40°F
LOWER SETPOINT	20°F to 70°F	30°F
VSP VALUE	0% to 80%	50%
LOAD LIMIT	0% to 100%	100%
T-DIFF	15 to 200 sec	90 sec
FAIL INDIC	0% to 90%	0%
LEAD COMP	M1-1 to M14-2	M1-1
NUM OF MODULES	1 to 14	1
MAN. SETPOINT	25°F to 70°F	45°F
MAN. RANGE	2°F to 20°F	10°F
MAN. OFFSET	0°F to 5°F	2°F
FAN SETPT	170 to 350 psig	235 psig
FAN OFFSET	20 to 60 psig	30 psig
HP CUTOUT	300 to 425 psig	365 psig
SEQUENCE	STANDARD or ODD/EVEN	STANDARD
INDEXING	OFF or ON	ON

Module Cutouts and Reset Points

Low Suction Temp	Cutout → 15°F	Reset @ 20°F
Low Leaving CHW	Cutout → 20°F	Reset @ 25°F
Low Pressure	Cutout → 15 psig	Reset @ 30 psig

LOW SUCTION FAULT

The low suction fault in the low temperature and low ambient application works differently than in the standard program. One compressor in the module must be on for 30 seconds before a low suction fault can occur. This allows the suction line to increase its temperature on a cold start before receiving a fault. The chiller system must have Glycol in place in order to have the low temperature or low ambient program options available. This is measured by the module suction sensor and would affect the entire module. If during operation this temperature should drop below 15°F, the module's compressors will shut down. This requires resetting at the *master controller*, but only after the temperature has risen above 20°F.

Compressor Rotations

Lead in the rotation is the SYSTEM LEAD. SYSTEM LEAD is the time between the start of the compressor stroke and the start of the lead compressor stroke. This value is used to determine the correct rotation for the compressor.

Non-indexing and standard sequencing

The LEAD COMPRESSOR would rotate by one at midnight each night. There would be an eight day rotation for a four week cycle.

APPENDIX D

DEFINITION OF COMPRESSOR ROTATIONS

The LEAD COMPRESSOR would rotate by one at midnight each night. There would be an eight day rotation for a four week cycle.

Day 1	M1-1, M1-2, M1-3, M1-4, M1-5, M1-6, M1-7, M1-8, M1-9, M1-10, M1-11, M1-12
Day 2	M2-1, M2-2, M2-3, M2-4, M2-5, M2-6, M2-7, M2-8, M2-9, M2-10, M2-11, M2-12
Day 3	M3-1, M3-2, M3-3, M3-4, M3-5, M3-6, M3-7, M3-8, M3-9, M3-10, M3-11, M3-12
Day 4	M4-1, M4-2, M4-3, M4-4, M4-5, M4-6, M4-7, M4-8, M4-9, M4-10, M4-11, M4-12
Day 5	M5-1, M5-2, M5-3, M5-4, M5-5, M5-6, M5-7, M5-8, M5-9, M5-10, M5-11, M5-12
Day 6	M6-1, M6-2, M6-3, M6-4, M6-5, M6-6, M6-7, M6-8, M6-9, M6-10, M6-11, M6-12
Day 7	M7-1, M7-2, M7-3, M7-4, M7-5, M7-6, M7-7, M7-8, M7-9, M7-10, M7-11, M7-12
Day 8	M8-1, M8-2, M8-3, M8-4, M8-5, M8-6, M8-7, M8-8, M8-9, M8-10, M8-11, M8-12

Indexing and standard sequencing

The LEAD COMPRESSOR would rotate by one at midnight each night. There would be an eight day rotation for a four week cycle.

Day 1	M1-1, M1-2, M1-3, M1-4, M1-5, M1-6, M1-7, M1-8, M1-9, M1-10, M1-11, M1-12
Day 2	M2-1, M2-2, M2-3, M2-4, M2-5, M2-6, M2-7, M2-8, M2-9, M2-10, M2-11, M2-12
Day 3	M3-1, M3-2, M3-3, M3-4, M3-5, M3-6, M3-7, M3-8, M3-9, M3-10, M3-11, M3-12
Day 4	M4-1, M4-2, M4-3, M4-4, M4-5, M4-6, M4-7, M4-8, M4-9, M4-10, M4-11, M4-12
Day 5	M5-1, M5-2, M5-3, M5-4, M5-5, M5-6, M5-7, M5-8, M5-9, M5-10, M5-11, M5-12
Day 6	M6-1, M6-2, M6-3, M6-4, M6-5, M6-6, M6-7, M6-8, M6-9, M6-10, M6-11, M6-12
Day 7	M7-1, M7-2, M7-3, M7-4, M7-5, M7-6, M7-7, M7-8, M7-9, M7-10, M7-11, M7-12
Day 8	M8-1, M8-2, M8-3, M8-4, M8-5, M8-6, M8-7, M8-8, M8-9, M8-10, M8-11, M8-12

Compressor Rotations

Based on the settings in the *SYSTEM VARIABLES* of SEQUENCE and INDEXING, the LEAD COMPRESSOR can change from day to day. This would also change the order that the compressors would turn on or off. The following are some common configurations and how the compressors would stage in that particular configuration.

Non-indexing and Standard Sequencing

The LEAD COMPRESSOR would be the first on and the last off. The LEAD COMPRESSOR would always be M1-1, unless changed in the *SYSTEM VARIABLES*. The compressors would then come on in numerical order.

M1-1, M1-2, M2-1, M2-2, M3-1, M3-2, M4-1, M4-2

Non-indexing and Odd/Even Sequencing

The LEAD COMPRESSOR would always be M1-1, unless changed in the *SYSTEM VARIABLES*. The compressors would come on all odd first and then all even or all even first, if the LEAD COMPRESSOR was even, and then all odd.

Odd lead compressor → M1-1, M2-1, M3-1, M4-1, M1-2, M2-2, M3-2, M4-2

Even lead compressor → M1-2, M2-2, M3-2, M4-2, M1-1, M2-1, M3-1, M4-1

Indexing and Standard Sequencing

The LEAD COMPRESSOR would rotate by one at midnight each night. There would be an eight day rotation schedule for a four module chiller.

Day 1	M1-1, M1-2, M2-1, M2-2, M3-1, M3-2, M4-1, M4-2
Day 2	M1-2, M2-1, M2-2, M3-1, M3-2, M4-1, M4-2, M1-1
Day 3	M2-1, M2-2, M3-1, M3-2, M4-1, M4-2, M1-1, M1-2
Day 4	M2-2, M3-1, M3-2, M4-1, M4-2, M1-1, M1-2, M2-1
Day 5	M3-1, M3-2, M4-1, M4-2, M1-1, M1-2, M2-1, M2-2
Day 6	M3-2, M4-1, M4-2, M1-1, M1-2, M2-1, M2-2, M3-1
Day 7	M4-1, M4-2, M1-1, M1-2, M2-1, M2-2, M3-1, M3-2
Day 8	M4-2, M1-1, M1-2, M2-1, M2-2, M3-1, M3-2, M4-1

Indexing and Odd/Even Sequencing

The LEAD COMPRESSOR would rotate at midnight following the odd/even pattern. There would be an eight day schedule for a four module chiller.

Day 1	M1-1, M2-1, M3-1, M4-1, M1-2, M2-2, M3-2, M4-2
Day 2	M2-1, M3-1, M4-1, M1-1, M2-2, M3-2, M4-2, M1-2
Day 3	M3-1, M4-1, M1-1, M2-1, M3-2, M4-2, M1-2, M2-2
Day 4	M4-1, M1-1, M2-1, M3-1, M4-2, M1-2, M2-2, M3-2
Day 5	M1-2, M2-2, M3-2, M4-2, M1-1, M2-1, M3-1, M4-1
Day 6	M2-2, M3-2, M4-2, M1-2, M2-1, M3-1, M4-1, M1-1
Day 7	M3-2, M4-2, M1-2, M2-2, M3-1, M4-1, M1-1, M2-1
Day 8	M4-2, M1-2, M2-2, M3-2, M4-1, M1-1, M2-1, M3-1

The remote display is used to display the contents of the remote computer screen on the local computer screen. The remote display is a software program that runs on the remote computer and the local computer. The remote display is installed on the remote computer and the local computer. The remote display is used to display the contents of the remote computer screen on the local computer screen. The remote display is a software program that runs on the remote computer and the local computer. The remote display is used to display the contents of the remote computer screen on the local computer screen.



APPENDIX E

The remote display is used to display the contents of the remote computer screen on the local computer screen. The remote display is a software program that runs on the remote computer and the local computer. The remote display is used to display the contents of the remote computer screen on the local computer screen. The remote display is a software program that runs on the remote computer and the local computer. The remote display is used to display the contents of the remote computer screen on the local computer screen.

REMOTE DISPLAY

If the remote display is not displaying the correct information, you may need to adjust the display settings. Press the F10 key to open the Remote Display Setup menu. Use the arrow keys to navigate to the Display Settings option and press the ENTER key. The display settings menu will appear. Use the arrow keys to navigate to the Display Resolution option and press the ENTER key. The display resolution menu will appear. Use the arrow keys to navigate to the desired resolution and press the ENTER key. The display will refresh with the new resolution.

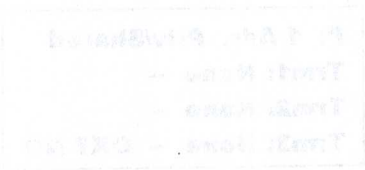

APPENDIX E

REMOTE DISPLAY

The remote display feature allows you to view the remote display on your local computer. To use the remote display feature, you must first enable the remote display feature in the BIOS. Press the F10 key to open the Remote Display Setup menu. Use the arrow keys to navigate to the Remote Display option and press the ENTER key. The remote display menu will appear. Use the arrow keys to navigate to the Remote Display option and press the ENTER key. The remote display feature will be enabled.

Remote Display Setup

If the remote display is not displaying the same information the master is, follow these steps to correct it. First look on the back of the remote display, the DIP switches should be addressed to 32, which should be all switches off except for switch number 6, which should be on. Hold down the 3 buttons in the lower right corner of the remote display, **UP** and **DOWN** arrow buttons and the **ENTER** button. A screen will come up with Terminal Adr: 32 and I/O Adr: 30. The I/O Adr: should be a value of 30, to point the remote display at the master controller. Press **ENTER**, the next screen says *Terminal config press ENTER to continue*. Press **ENTER** to go to the remote setup screen. This screen looks like the following illustration.

P: 30 Adr. Priv/Shared
Trm1: 32 Pr
Trm2: None --
Trm3: None -- OK? NO

Figure 1

P: 1 Adr. Priv/Shared
Trm1: None --
Trm2: None --
Trm3: None -- OK? NO

Figure 2

The number after the P would be the address of the DIP switch on the board. For the remote display to work properly, this screen should look exactly like Figure 1 for the master controller (30) only. Press the **ENTER** button until NO is reached and change to YES. Every module, 1 – 14 should look like Figure 2. Every module number in the network needs to be setup to look like Figure2. For each new module, this requires starting from the beginning. To change the number of the I/O Adr, use the **UP** and **DOWN** arrow buttons.

The Program Key is used to start and stop the program. It is located on the front panel of the control. The Program Key is used to start and stop the program. It is located on the front panel of the control. The Program Key is used to start and stop the program. It is located on the front panel of the control.

DOWNLOADING A PROGRAM

Downloading a program is a simple process. First, you need to have the program on a floppy disk. Then, you need to have the control ready to receive the program. The control will prompt you for the program name and the number of the program. Enter the program name and the number of the program. The control will then download the program to the control.

APPENDIX F

PROGRAMMING KEY

1. Press the Program Key to start the program.
2. Press the Program Key to stop the program.
3. Press the Program Key to start the program.
4. Press the Program Key to stop the program.
5. Press the Program Key to start the program.
6. Press the Program Key to stop the program.
7. Press the Program Key to start the program.
8. Press the Program Key to stop the program.
9. Press the Program Key to start the program.
10. Press the Program Key to stop the program.
11. Press the Program Key to start the program.
12. Press the Program Key to stop the program.
13. Press the Program Key to start the program.
14. Press the Program Key to stop the program.
15. Press the Program Key to start the program.
16. Press the Program Key to stop the program.
17. Press the Program Key to start the program.
18. Press the Program Key to stop the program.
19. Press the Program Key to start the program.
20. Press the Program Key to stop the program.
21. Press the Program Key to start the program.
22. Press the Program Key to stop the program.
23. Press the Program Key to start the program.
24. Press the Program Key to stop the program.
25. Press the Program Key to start the program.
26. Press the Program Key to stop the program.
27. Press the Program Key to start the program.
28. Press the Program Key to stop the program.
29. Press the Program Key to start the program.
30. Press the Program Key to stop the program.



PROGRAM KEY

The Program Key is an electronic card which allows transfer of the program from the key to the pCO² controller and vice-versa. The Key contains a two position switch, a LED on the top of the key, and a connector to place the key on the memory card to transfer the program. The following step by step directions are for downloading a program.

DOWNLOADING A PROGRAM

Downloading a program is taking a program from the key and putting it on the pCO² controller. Each controller must have the new program installed for the chiller to perform properly. To download the program to the controllers, the remote display will be needed.

1. Record all *SYSTEM VARIABLES* from the current program.
2. Command the chiller **off**.
3. Unplug the pLan connections from **all** controllers at the J11 port.
4. Set the Manual/Off/Auto switch in **all** modules to **off**.
5. In the module to be programmed, turn **off** the power to the controller at CB5, the single pole circuit breaker (see wiring diagram for further identification).
6. Set the dipswitches to **off** on the controller being programmed.
7. Remove the "Expansion Memory" cover with a small screwdriver.
8. Set the switch on the Program Key to the "key to pCO" position.
9. Insert the key connector onto the memory card inside the "Expansion Memory" port.
10. Connect the remote display to the J10 port. Prior to connecting the display, make sure the dipswitches are in the off position on the remote display.
11. Press simultaneously the **UP** and **DOWN** arrow buttons at the remote display, while cycling the power on to the controller at CB5.
12. Check the color of the LED on the Program Key; it should be **red** at this time. If the LED is green, cycle power off; carefully remove the Program Key and position the switch to the "key to pCO" position. Then repeat steps 9 through 12.
13. Continue holding the buttons until confirmation of copying the program appears on the display.
14. Release the buttons and confirm to copy the program by pressing the **ENTER** button.
15. The display will run through a series of numbers and letters and then return to a self test screen.
16. When the self test screen is reached, cycle the power off at CB5.
17. Remove the remote display from the J10 port.
18. Carefully remove the Program Key.
19. Replace the "Expansion Memory" port cover.
20. Return the dipswitches for that controller to their original positions.
21. Cycle the power on at CB5.
22. Repeat steps 5 through 21 for all remaining controllers.
23. After all controllers have been programmed, plug in the pLan connections of **all** controllers at the J11 port.
24. Cycle the power off at CB5, of the master controller module only, for 5 seconds.
25. Cycle the power on at CB5.
26.  While on the 12 second delay screen of the program, simultaneously press the **PRG** and **UP** arrow buttons, and hold until the backlight dims, then release. Then simultaneously press the **DOWN** arrow and **ALARM** buttons. This resets the program to all default values.
27. Reset the *SYSTEM VARIABLES* to the values recorded before downloading the new program.
28. Set the Manual/Off/Auto switch in all modules to **on**.
29. Chiller is now ready to be commanded **on** again.

NOTE: If absolutely necessary, the modules not being programmed can be run in *Manual Mode*, by switching the Manual/Off/Auto switch into Manual instead of off. Please keep in mind that there is **NO FLOW PROTECTION** or **POWER PHASE PROTECTION** in *Manual Mode*. The Manual/Off/Auto switch should be switched to **off**, when programming that module.

The free cool module will take the module out of the normal operation and will start the compressor. The process will continue until the module is cooled down to the set point. The compressor will then stop and the module will return to normal operation. The controller will monitor the module temperature and will start the compressor if the temperature is higher than the set point. The controller will also monitor the power supply and will stop the compressor if the power is not available. The controller will also monitor the module status and will stop the compressor if the module is not in a normal state.

There are three main control modes for the free cool module: (see page 12 below) 1. Manual Control (M) 2. Low Temp. Control (L) 3. Free Cool Control (F) 4. Maintenance Mode (see maintenance manual for more details). The module will operate in one of these modes. The controller will start the compressor if the temperature is higher than the set point. The controller will also monitor the power supply and will stop the compressor if the power is not available. The controller will also monitor the module status and will stop the compressor if the module is not in a normal state.

APPENDIX G

MANUAL FOR FREE COOL MODULES

Figure 2 - Free Cool Thermostat

Variables Set by Thermostat

CLIMATE CONTROL: The thermostat controls the panel when the free cool module is on. It will start the compressor if the temperature is higher than the set point. The controller will also monitor the power supply and will stop the compressor if the power is not available. The controller will also monitor the module status and will stop the compressor if the module is not in a normal state.

LOW TEMPERATURE: The thermostat will start the compressor if the temperature is lower than the set point. The controller will also monitor the power supply and will stop the compressor if the power is not available. The controller will also monitor the module status and will stop the compressor if the module is not in a normal state.

FREE COOL CONTROL: The thermostat will start the compressor if the temperature is higher than the set point. The controller will also monitor the power supply and will stop the compressor if the power is not available. The controller will also monitor the module status and will stop the compressor if the module is not in a normal state.

Free Cool Set Point

The free cool set point is the temperature at which the compressor will start. The set point is adjustable and can be set between 55°F and 65°F. The controller will start the compressor if the temperature is higher than the set point. The controller will also monitor the power supply and will stop the compressor if the power is not available. The controller will also monitor the module status and will stop the compressor if the module is not in a normal state.

Free Cool Modules

A *Free Cool Module* is designed to take advantage of the outdoor ambient temperature to pre-cool the chilled water before it enters the *mechanical cooling modules*. This process will reduce the number of *mechanical cooling modules* operating based on outdoor ambient temperature. The cooler the ambient temperature, the fewer requirements there will be for *mechanical cooling modules*. Therefore saving the customer money, since the power requirements to operate a fan motor are far less than the requirements to operate a compressor.

There are three main controls in a *free cool module* (See Fig. 3 below): Change Over Control(1), Low Temp. Lockout(2), and Fan Cycling Control(3). By manipulating these three mechanical thermostats, the module will cycle the fans *on* or *off*, as well as control a diverting valve to either force the fluid through the coils or bypass around the coils.

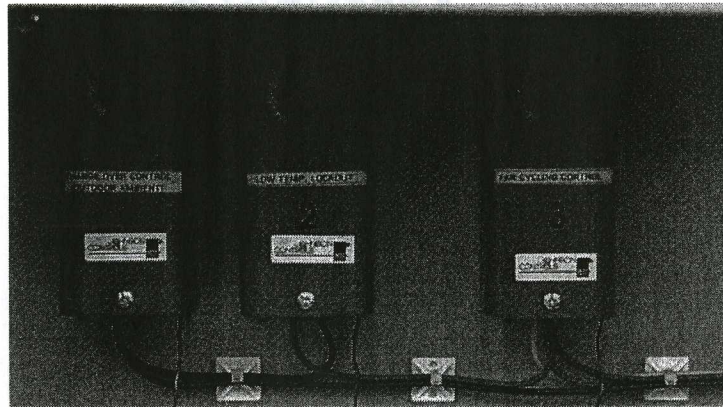

Figure 5 - Free Cool Thermostats

Variables Set by Thermostats

1. **CHANGE OVER CONTROL:** This thermostat controls the point where the *free cool module* is enabled or disabled, and is based on the outdoor ambient temperature. If the ambient temperature is below the thermostat setting, the *free cool module* is enabled. The fluid diverting valve will move to the right, and force the fluid to flow through the coils above.
2. **LOW TEMP LOCKOUT:** The minimum desired fluid temperature leaving the *free cool modules* and entering the *mechanical cooling modules*. If the fluid temperature gets this low, then the *free cool modules* will be disabled and the fluid diverting valve will move to the left and force the fluid to bypass the coils above.
3. **FAN CYCLING CONTROL:** This thermostat monitors the fluid temperature leaving the diverting valve. If the temperature of the fluid is above the setting on the thermostat, the fans will cycle *on*, as long as the module is enabled from 1 and 2 above. This thermostat is a two stage thermostat and has a built in 2°F differential between stages. This is a non-adjustable differential.

Remote Start/Stop

The user can control the *free cool module* from a remote location by providing a dry contact closure between terminals 1 and 4 of TS2. If the contact is open, the *free cool module* would be disabled. If the contact is closed, then the control of the module would be based on the setting of the three thermostats. There should be a jumper between terminals 1 and 4 of TS2 when received from the factory. This jumper needs to be removed in order to utilize the Remote Start/Stop.

A Chiller Enhancement From...



How do you **INCREASE** your **ENERGY EFFICIENCY** while **REDUCING** your **MAINTENANCE COSTS?**

MULTISTACK has the solution:
Chiller Supply Header Filter Strainers*

The 316 Stainless Steel Strainer with a Teflon coated 30 mesh screen is designed to provide protection to the brazed plate heat exchanger. This lining prevents harmful debris contamination that leads to higher energy costs.

**U.S. Patent #5.395.524*

- *MULTISTACK chillers with filter strainers provide 7 - 13 times more surface area than the alternative "Y Basket" strainers.*
- *Teflon coated filter strainers are now standard equipment in all MULTISTACK modules.*
- *The pressure drop increases by only 7% on a five module chiller.*

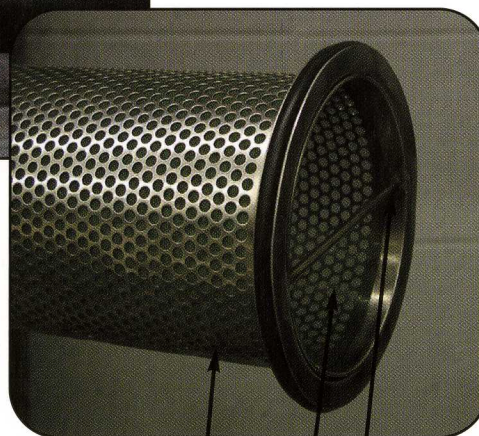

Filter Strainer

Teflon Coated 30 Mesh Screen

Filter Pull Rod

Possible debris contaminates that drive up your energy costs include:

- *Metal Chips*
- *Slag*
- *Dirt*
- *Insects*
- *Plastic Particles*
- *Rust*
- *Plant Seeds*

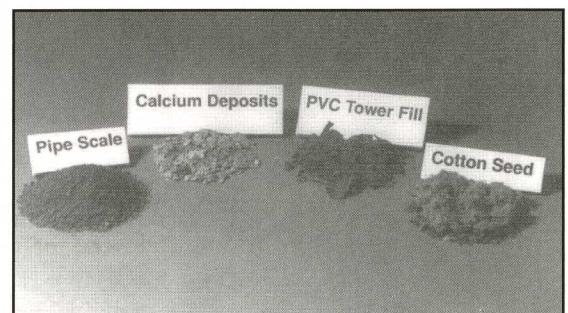



Cleaning Procedure

- *Remove the filter strainers from the header and spray it with a water hose. With a mild household detergent simply wash the mesh screen until the debris is removed.*
- *MULTISTACK recommends cleaning at the end of each cooling season or whenever the refrigerant discharge pressure gauge exceeds 40 - 50lbs above normal operating conditions. We also recommend cleaning the chilled water filter strainers when the evaporator is operating at 52 psig or 10-12 psig below normal.*

Note: Refer to the MULTISTACK Installation Manual for instructions on cleaning the system prior to installing the Multistack Chiller.

- *For normal air conditioning application 55 - 45°F entering and 105°F condensing, the optimal operating conditions are: 60 - 62 psig suction, and 200 - 212 discharge pressure.*

Note: Operating conditions vary depending on the application, temperatures and flow rates.

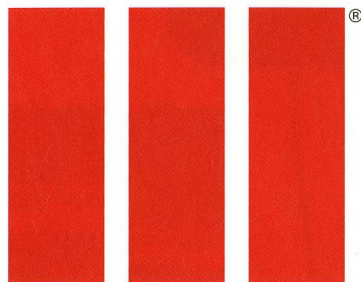

MULTISTACK

P.O. Box 510
1065 Maple Avenue
Sparta, WI 54656
Phone 608-366-2400
Fax 608-366-2450
www.multistack.com

The Leader in Modular Chillers

Now Available From MULTISTACK... **151A Cleaning Kit™**

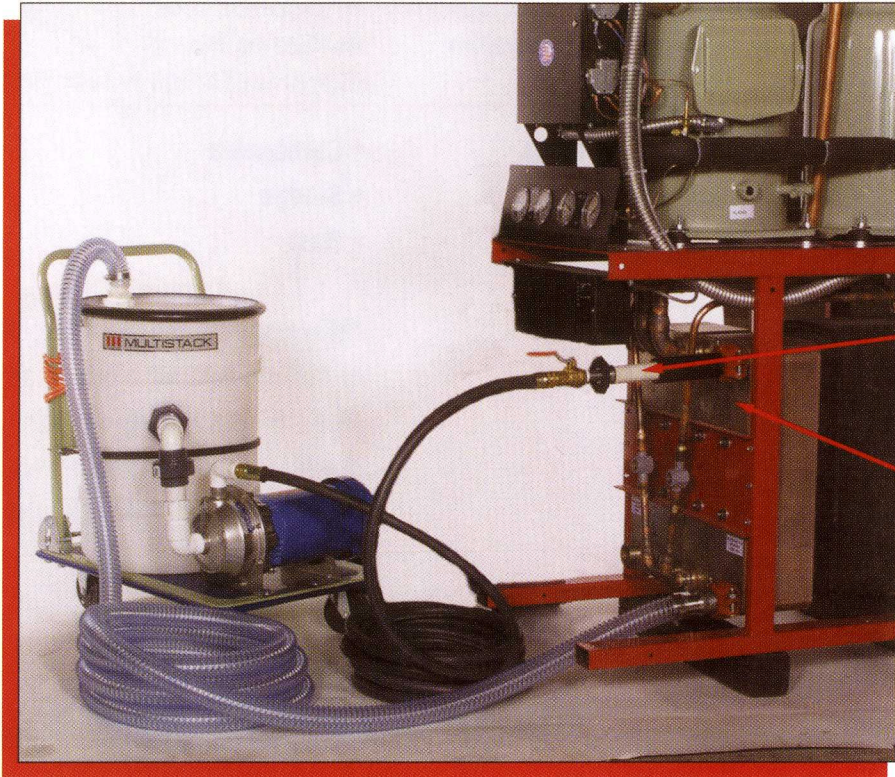
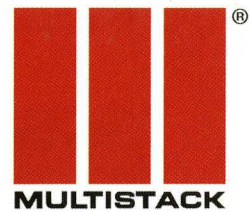

FlushGun™

Heat Exchanger

Note: Illustrated instructions for cleaning MULTISTACK heat exchangers are available through the factory, document #091594 *Heat Exchanger Cleaning Procedures*

Problem:

Brazed plate heat exchanger fouling, due to foreign debris contamination of the condenser and evaporator, reduces the heat transfer area and chiller performance.

Solution:

MULTISTACK, Inc. has designed the 151A Heat Exchanger Cleaning Kit. This cleaning kit allows the customer to quickly and efficiently clean both the condenser and the evaporator (approximately 50 minutes per heat exchanger).

The MULTISTACK 151A Cleaning Kit Includes:

- (2) FlushGuns™ with grooved Victaulic connectors to clean the individual passages of the heat exchangers
- (1) 1-hp 120 volt 60 psig pump
- (1) 15 gallon holding tank suitable for use with mild acids or detergents (see reverse side)
- All necessary hoses and connectors
- All components of the kit are mounted on a heavy duty, easy to maneuver cart

Keep your
MULTISTACK Chiller
running energy
efficient and problem
free with the new
MULTISTACK 151A
Cleaning Kit™



Recommended Cleaning Solutions:

The MULTISTACK Chiller's heat exchangers can be cleaned using the 151A Cleaning Kit with a Detergent Soak or Acid Flush. Each solvent offers an advantage for removing specific types of debris.

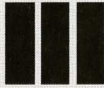

Detergent Soak

Liquid Dish Soap or Sodium Hydroxide and hot water (140° F)

- Dirt and Sand Particles
- Cottonwood Seeds
- Leaves
- Oil or Grease

Acid Flush

Phosphoric or Sulfamic Acid*

(Contact MULTISTACK for availability)

- Carbonates
- Sludge
- Rust

***Warning:** Do not use hydrochloric or sulfuric acid for cleaning any MULTISTACK Heat Exchanger. Any chemical used must be compatible with copper and stainless steel.

Note: Cleaning is complete when debris is no longer being discharged from the heat exchanger, or when acid solution is no longer being depleted.

Order your 151A MULTISTACK Cleaning Kit today!

It is available for immediate delivery. Get your cooling season off to a clean start.

MULTISTACK, Inc.
 1065 Maple Avenue
 PO Box 510
 Sparta, WI 54656
 Phone: (608) 366-2400
 Fax: (608) 366-2450
www.airstack.com

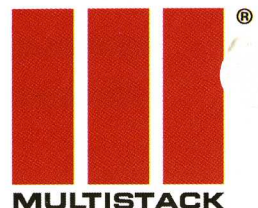



Annual Cleaning Procedure for Shut-down of MULTISTACK Chillers

MULTISTACK Chillers utilize Heat Exchangers that differ greatly in design, construction and performance from other types of heat exchangers (e.g., shell and tube design), and have completely different fouling characteristics. For best performance, MULTISTACK recommends taking the first step in fighting fouling: **PREVENTION**.



Brazed plate heat exchangers make each MULTISTACK module highly efficient. This side view of a module, without cabinetry, shows the location of the heat exchangers.

Preventative Maintenance



The evaporator system is shown in this illustration. A complex series of channels within each heat exchanger gives rise to vigorous turbulence, ensuring maximum heat transfer.

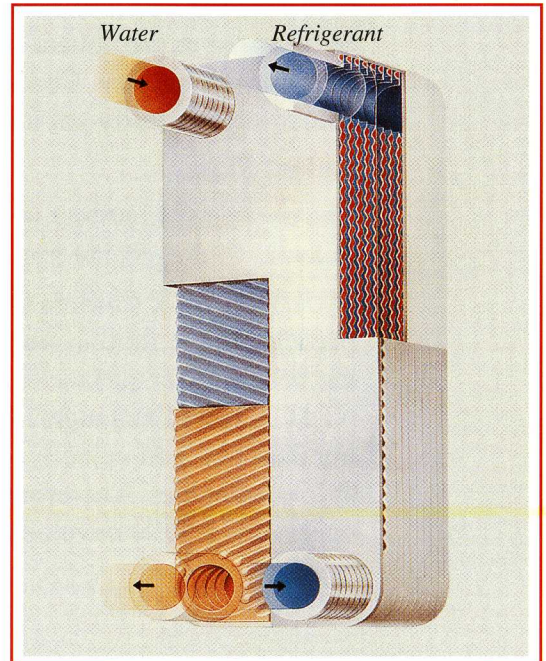



FACTORS AFFECTING FOULING

- Temperature
- Velocity
- Surface Finish
- Turbulence
- Flow Distribution
- Water Quality



TYPES OF FOULING: Scaling and Particulate

Scaling

Scaling is caused by substances dissolved in the heat transfer medium which deposit on the heat transfer surface. To prevent or minimize scaling, a proper water treatment program designed by a competent water treatment professional is recommended.

Particulate

Particulate fouling is caused by solids in the heat transfer medium such as mud, silt, sand or other particles. Particulate fouling is affected by velocity, distribution of the medium, roughness of the heat transfer surface and the size of the particles. Particles can enter the heat exchanger through old rusty pipes or through the cooling tower.

To reduce particulate fouling, MULTISTACK recommends a good filtration system (i.e., strainers, sand filters, mechanical/centrifugal separators).

Note: A Teflon Coated Stainless Steel cartridge filter for the evaporator and condenser header is supplied with all MULTISTACK modules to remove particles. If required, other types of filtration systems can be added to meet specific filtration parameters.



Laminar vs. Turbulent Flow

Laminar

When a fluid passes through a tube the greatest velocity is at the center of the tube. The tube wall has no turbulence to keep particles in the fluid in suspension. These particles are allowed to precipitate out and collect on the tube wall which causes fouling of the heat transfer surface. Conventional types of heat exchangers are very sensitive to low velocities and easily get into the laminar region.

Turbulent Flow

The opposite of laminar is turbulent flow. Operating with turbulent flow is the best way to avoid fouling in the heat exchangers.

MULTISTACK Chillers dispense a high degree of turbulence to the fluid which keeps particles in the fluid in suspension, and actually performs a scouring action to help keep the heat transfer surface clean. This is accomplished by the unique design of the MULTISTACK Heat Exchanger. As the water passes through the channels it is constantly changing direction and velocity, disturbing the boundary layer and creating turbulent flow even at low velocities. Therefore, the MULTISTACK Modular Water Chiller will always operate with fully developed turbulence.



PREVENTIVE MAINTENANCE

Annual cleaning of the heat exchangers is recommended. If the chiller is shut down for a non-cooling season, the following cleaning procedure should be performed at time of shut down:

1. Isolate chiller (both condenser and chilled water circuits).
2. Drain chiller.
3. Backflush chiller with water to remove foreign materials.
4. Fill chiller with clean water.

WARNING: Do not use hydrochloric or sulfuric acid for cleaning any MULTISTACK Heat Exchangers. Make sure any chemicals used are compatible with copper and stainless steel.

NOTE: Operating conditions may indicate more frequent cleaning is required. A rise in discharge pressure to above 260 psi (at normal condenser water temperature) or a reduction in evaporator heat transfer, low suction pressure, and low chilled water temperatures are examples of such indicators.

If the above procedure does not restore normal operating conditions, consult the MULTISTACK *Heat Exchanger Cleaning Procedures*.



CORROSION RESISTANCE

Corrosion is a complex process influenced by many different factors. Although stainless steels are considered corrosive resistance, AISI 316 and 316L stainless steel are not resistant to chloride concentrations above 300 parts per million (ppm). MULTISTACK Heat Exchangers are made of stainless steel plates brazed together with copper (99.9%).

CAUTION: Knowing the chloride content of your supply water is essential. A qualified water treatment professional should test your water for chloride levels and treat the water accordingly.

CAUTION: Chloride concentrations above 300 ppm will damage stainless steel heat exchangers.

CAUTION: Do not add any chemicals to the water without consulting with a water treatment professional to make sure that treatment is compatible with all materials in the system including copper and stainless steel. Do not use sulfuric or hydrochloric acid.

MULTISTACK TROUBLESHOOTING GUIDE

SOURCE OF CONTAMINANTS	POSSIBLE SOLUTION
<p>Water Impurities</p> <p>Oil <i>Oil film build-up in the condenser or evaporator will reduce the transfer.</i></p> <p>Chlorides <i>Chlorides entering the condenser or evaporator will corrode the brazed plate heat exchangers.</i></p> <p>pH-Level <i>High acid levels entering the condenser or evaporator will cause corrosion.</i></p> <p>Calcium <i>Calcium build-up in the condenser will reduce the heat transfer, as well as water flow through the system.</i></p>	<ol style="list-style-type: none"> 1. Organic materials can be removed with detergent cleaning. 2. Maintain chloride levels below 300 ppm. 3. pH levels should be maintained between 7 and 9. 4. Inorganic contaminants can be removed by mild cleaning with phosphoric or sulfamic acid (e.g., NACLEAN 2568™ Scale Remover, NALCO Chemical Co.; or DrewClean-20™, Drew Industries - A Division of Ashland Chemical Co.). DO NOT USE HYDROCHLORIC OR SULFURIC ACID 5. Have a water treatment contractor test your water and recommend a proper treatment plan. 6. Make sure the contractor is familiar with the components of the system (e.g., 316 stainless steel heat exchanger, and copper brazing material).
<p>System Impurities</p> <p>Rust Pipe Scale Welding Slag and Other Debris</p> <p>Internal contaminants present in the water pipes can enter the MULTISTACK condenser or evaporator, plugging up the filters and ultimately the heat exchangers.</p>	<ol style="list-style-type: none"> 1. When installing a new chiller, acid wash the condenser and evaporator water loop systems before connecting the water pipes to the MULTISTACK unit. 2. During normal system operation, observe the discharge pressure and clean filters if head pressures approach 280 psi (high pressure cut out trips at 290 psi).
<p>Cooling Tower Impurities</p> <p>Grass Algae Tower Fill Air-born Soot and Dirt Insects Cottonwood Seeds Construction Debris</p> <p>External contaminants enter the condenser of the MULTISTACK module through the cooling tower.</p>	<ol style="list-style-type: none"> 1. A filter (polyester or wire mesh) over the air inlet to the cooling tower will help prevent external contaminants from entering the cooling tower. 2. Drain and clean cooling towers as required. 3. Whenever possible, avoid placing cooling towers in close proximity to trees, smoke stacks or outside lights.

MULTISTACK®

365 South Oak Street
P.O. Box 854
West Salem, WI 54669

Phone: (608) 786-3400
Fax: (608) 786-3450

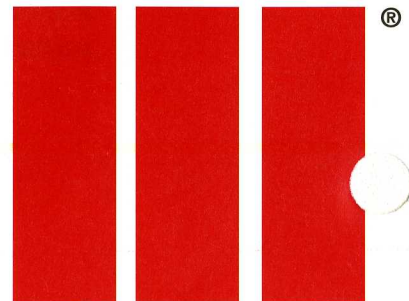



Cleaning the MULTISTACK stainless steel brazed plate heat exchanger can be done using FlushGun™ with an Acid Flush or Detergent Soak. Each solvent offers an advantage for removing specific types of debris.

Acid Flush

- Carbonates
- Sludge
- Rust

Detergent Soak

- Dirt and Sand Particles
- Fibrous Materials
- Grease
- Plastics

WARNING: Do not use hydrochloric or sulfuric acid for cleaning any MULTISTACK Heat Exchangers. Make sure any chemicals used are compatible with copper and stainless steel.

The MULTISTACK Heat Exchangers should always be cleaned from the outlet to inlet, by backflushing the particles from the corrugated passages.

- ① Victaulic Coupling
- ② Remove Condenser Headers
- ③ Remove Evaporator Headers



MULTISTACK has designed the 151A Heat Exchanger Cleaning Kit. This cleaning kit allows the customer to quickly and efficiently clean both the condenser and evaporator (approximately 50 minutes per heat exchanger).

Heat Exchanger Cleaning Procedures



PREPARING CHILLER FOR CLEANING

- Disconnect power to chiller.
- Isolate *Chilled Water Loop* by closing the condenser and evaporator isolation valves.

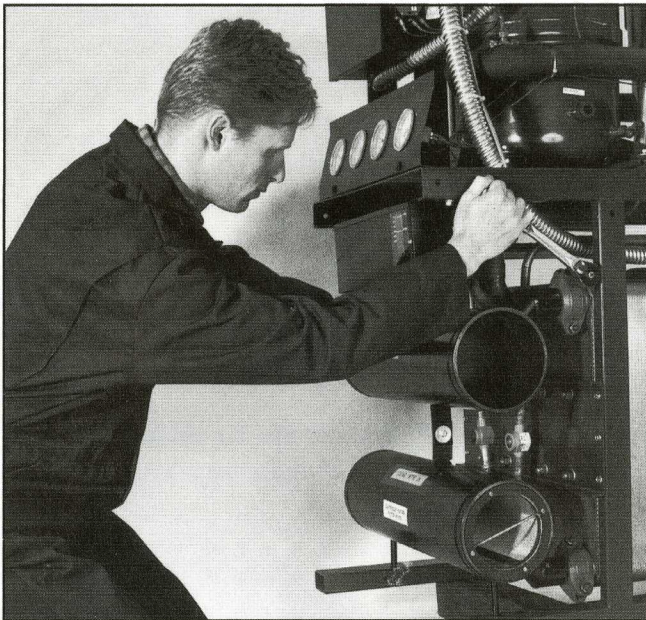

Figure 1: Removing header from heat exchanger.

- Remove end caps and drain the water from the condenser or evaporator (Figure 1).

CAUTION: *Be careful not to let the electrical connections get wet.*

- Remove the VICTAULIC COUPLINGS and HEADERS (Figure 1).

Note: *Install 6" long pipe to condenser or evaporator inlet, using one victaulic coupling and gasket that you removed from unit (Figure 2).*

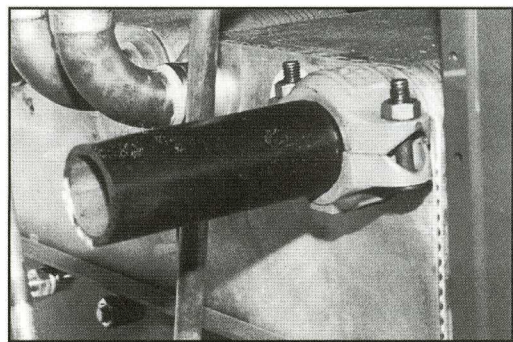

Figure 2: 6" Pipe connection.



PREPARE SOLVENT

Detergent

Dish soap and hot water (140° F)

CAUTION: *When cleaning difficult types of debris (i.e., grease), allow heat exchanger to soak in detergent 1½ hours.*

Acid

Phosphoric or sulfamic acid such as Nu-Calgon Imperial Grade Scale Remover part number 4360-84. Prepare acid solvent according to the chemical manufacturers' directions. If further assistance is required, call Multistack, Inc.

CAUTION: *When circulating solutions heated to temperatures above 128° F, the module high pressure switches will open. They will need to reset before starting.*

WARNING: *Do not use hydrochloric or sulfuric acid for cleaning any MULTISTACK Heat Exchangers. Make sure any chemicals used are compatible with copper and stainless steel.*

■ ■ ■ USING FLUSHGUN TO CLEAN INDIVIDUAL HEAT EXCHANGERS

FlushGun kits are available in different styles, depending on the heat exchanger model. To obtain the correct FlushGun kit, simply provide MULTISTACK with the initial purchase order for your modular chiller. The correct kit will be sent to you.

FlushGun A

- Connect hose to **FlushGun A**.
- Insert **FlushGun A** into the top outlet side opening of the condenser (bottom outlet of the evaporator) until it is against the back plate.

Step A: Tightening the compression nut clockwise until the tool cannot be removed. Open the hand valve slowly.

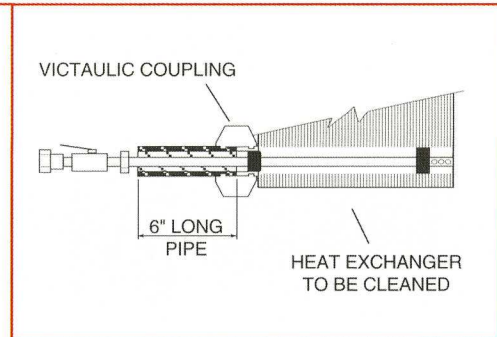

FlushGun A position mock-up.



Figure 3: Inserting FlushGun into heat exchanger.

Step B: Apply a minimum of 60 psig water pressure for ten full minutes or until all foreign particles have been flushed.

Note: If 60 psig is not available, connect a separate pump to compensate.

FlushGun B

- Loosen the compression nut and remove **FlushGun A**. Change hose connection to **FlushGun B**. Insert **FlushGun B** until it is at the back of the heat exchanger (Figure 3). **Repeat Steps A & B.**

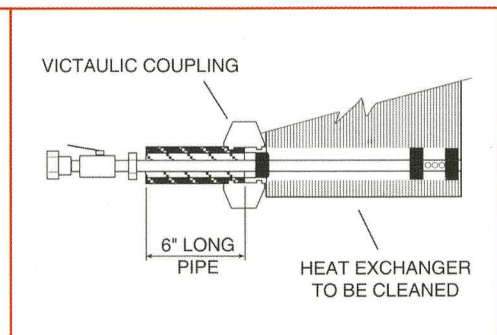

FlushGun B position mock-up.

Flush Gun B

- Loosen the compression nut and pull the tool out 1 $\frac{1}{4}$ ", measured at the back of the compression nut. Repeat 1 $\frac{1}{4}$ " increments until the entire heat exchanger has been cleaned. The 1 $\frac{1}{4}$ " increments are marked on the FlushGun as 1, 2, 3, and 4.

Repeat Steps A & B.

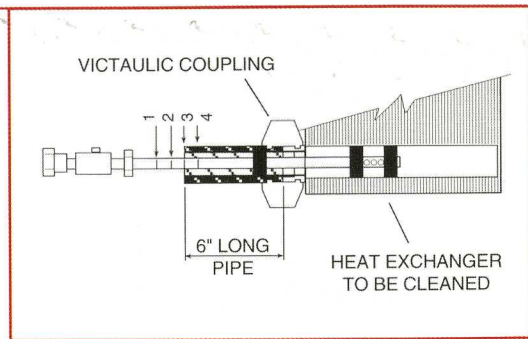

FlushGun B position mock-up.



FINAL CLEANING

- Repeat each of the steps for every heat exchanger until the entire chiller has been flushed.
- Once the chiller heat exchangers have been cleaned, take a standard garden hose sprayer and insert it into the inlet (condenser bottom/evaporator top) of the heat exchangers and apply full water pressure until all the debris has been dispersed from the plates.
 - Remove CARTRIDGE FILTERS from headers and clean with soap and wire brush.
 - Rinse CARTRIDGE FILTERS thoroughly with clean water.
- Remove scale from the headers with a wire brush and replace them. Attach VICTAULICS and reinstall CARTRIDGE FILTER.
- Backflush the entire chiller with clean water to ensure particles do not break free and enter the heat exchangers.

Note: See MULTISTACK Maintenance Instructions for information on fouling characteristics.

1065 Maple Avenue
P.O. Box 510
Sparta, WI 54656
Phone: 608-366-2400
Fax: 608-366-2450



#051404CP
Rev. 04-06

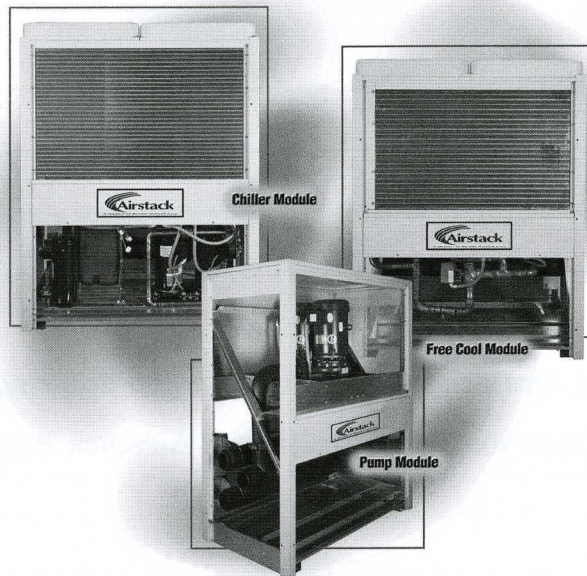

AIRSTACK
“ASP”
Air-Cooled Packaged
Chiller

Parts Book

AIRSTACK (Division of MULTISTACK)
1065 Maple Avenue
Box 510
Sparta, WI 54656
Phone 608-366-2400
Fax 608-366-2450
www.airstack.com

Job Name: _____

Job Number: _____

Model No.: _____

Serial No.: _____

Note: Please reference the Airstack model number when ordering replacement parts from your local Multistack/Airstack Representative.

Representative: _____

Phone: _____

If you require further service information please contact Multistack/Airstack Headquarters at 608-366-2400.

ASP Parts

Mechanical Cool Parts

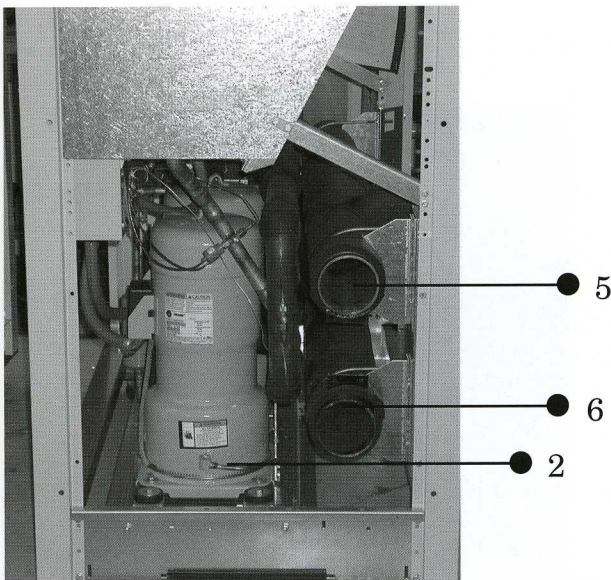
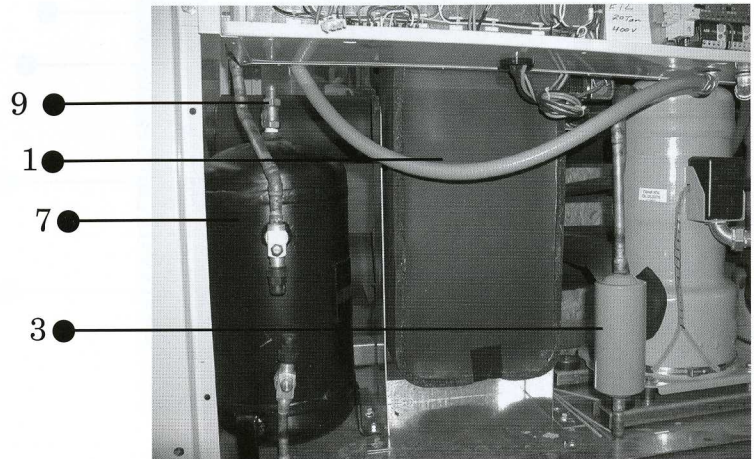

PART

1. Heatex 104
Heatex 52
Heatex 56
2. Compress 107 / 108
Compress 104 / 106
Compress 103 / 105
3. Drier 100
4. Valve 44 (not pictured)
Valve 45 (not pictured)
Valve 46 (not pictured)
5. Header 100
6. Header 101
7. Receiver 101
8. Valve 41(not pictured)
9. Valve 103

Description

- ASP-10 Evaporator
 ASP-15 Evaporator
 ASP-20 Evaporator
 5 ton 208V / 5 ton 460V (ASP-10)
 7.5 ton 208V / 7.5 ton 460V (ASP-15)
 10 ton 208V / 10 ton 460V (ASP-20)
 liquid line drier
 expansion Valve (ASP20)
 expansion Valve (ASP15)
 expansion Valve (ASP10)
 upper ECHW header
 lower LCHW header
 liquid receiver tank 40 lbs.
 liquid line solenoid valve
 pressure relief valve

ASP Parts

Mechanical Cool Components

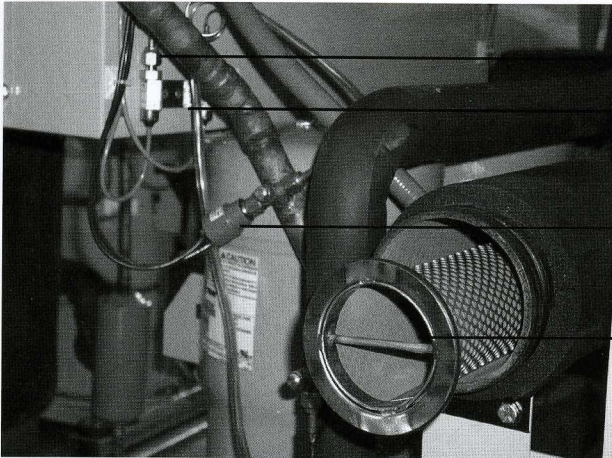

<u>Part#</u>	<u>Desc.</u>
A. Sensor 101	Low Pressure transducer
B. Sensor 100	High Pressure transducer
C. Switch 100	High Pressure switch
D. Filter 100	Evaporator filter

<u>Part#</u>	<u>Description</u>
1. Coil 101	Front condenser coil
2. Coil 100	Rear angled condenser
3. Motor 102	1 HP fan motor
Motor 101 (option)	1.5 HP fan motor

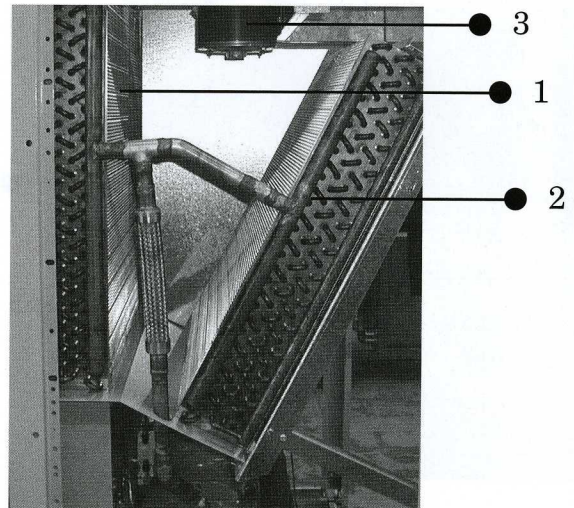

Not Pictured Parts:

<u>Part#</u>	<u>Description</u>	<u>Part#</u>	<u>Description</u>
Guard 100	Front steel grill	Gasket 100	4" Victaulic gasket
Shroud 100	Plastic fan shroud	Gasket 101	3" Victaulic gasket
Sensor 102	6' module CHW sensor	Guard 101	Fan motor steel guard
Sensor 105	12' system CHW sensor	Guard 102	Front coil guard
Sensor 106	24' system CHW sensor (option)	Valve 101	Free Cool control valve
Blank 100	4" Victaulic end cap	Fan 102	4 Blade 35p ASP 2
Blank 101	3" Victaulic end cap	Fan 103	4 Blade 25p ASP 10, 15, FC
Connect 104	2" braided hose for Free Cool	Fan 104	4 Blade 30p 7/8 Hub State Dept.
Couplin 101	4" Victaulic coupling		
Couplin 102	3" Victaulic coupling		
Gaugepanel 100	HP & LP gauge panel (option)		

ASP Parts

Mechanical Cool Components

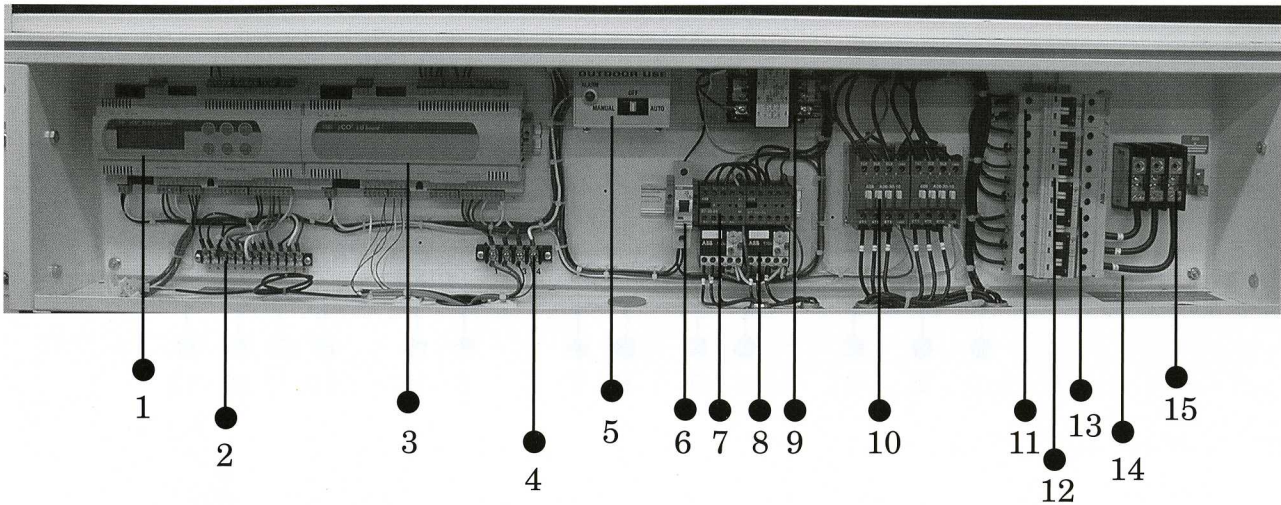

<u>Part</u>	<u>Description</u>	<u>Part</u>	<u>Description</u>
1. Board 104	Master Control Board	9. Transfo 100	208 or 460/24V
2. Block 100	12 pole terminal block	10. Contact 101	comp cont 32 amp 208V
3. Board 103	Slave Control Board	Contact 102	comp cont 25 amp 460V
4. Block 33	4 pole terminal block	11. CircB 100/105	2 pole 4 amp / 3 aamp
5. Switch 101	On/ Off/ Auto	12. CircB 103	3 pole 10 amp
6. CircBrk 101	1 pole 10 amp	13. CircB 102	3 pole 40 amp
7. Contact 100	fan o/l (208V)	14. CircBrk 102	3 pole 40 amp
8. Relay 100	fan o/l (208V)	15. Block 104	load wiring input block
Relay 102	fan o/l (460V)		

Free Cool

Electrical Components

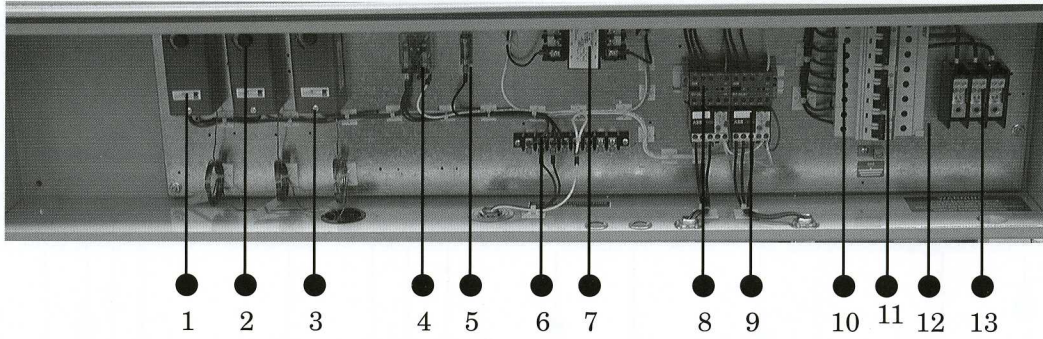

Free Cool

Parts

<u>Part#</u>	<u>Description</u>
1. Coil 102	front water coil
2. Coil 103	rear angled water coil
3. Header 103	4 upper header pipe
4. Header 104	4 middle header pipe
5. Header 105	4 lower header pipe
6. Motor 102	1 HP motor
Motor 101	1.5 HP motor (option)

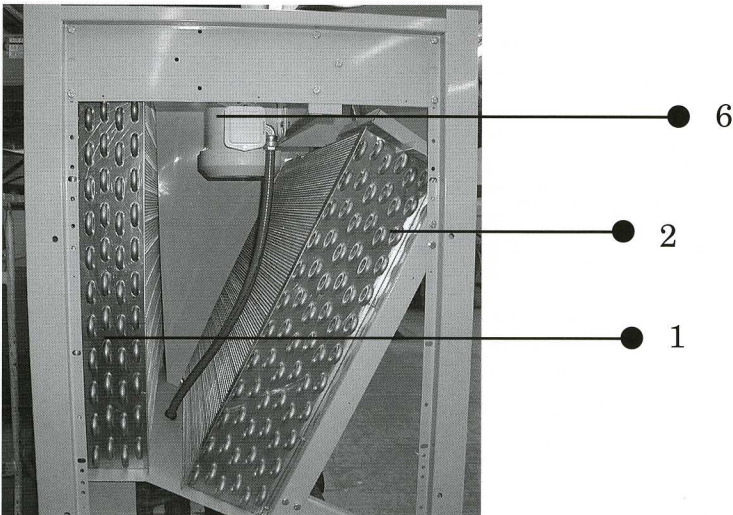
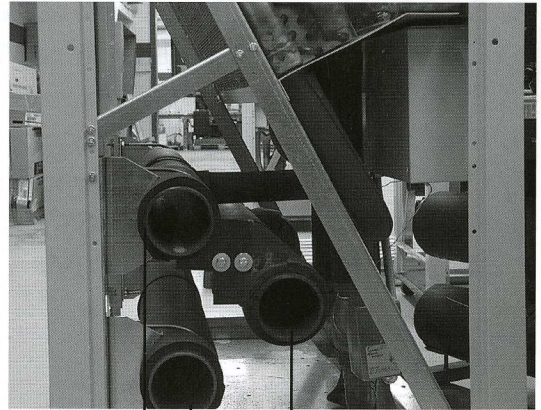

Pump Module

Electrical Components

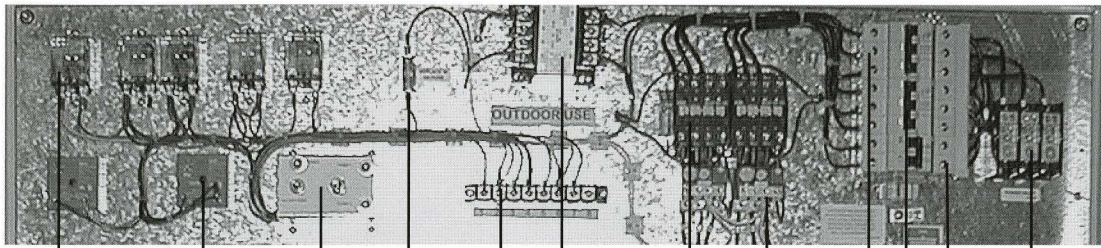

14 15 16 17 18 19 20 21 22 23 24 25

FREE COOL

Part	Description
1. Sensor 103	1 pole temp control
2. Sensor 103	1 pole temp control
3. Sensor 104	2 pole fan cycle
4. Relay 23	24V coil 250V
5. Fuse 32	5 amp fuse
6. Block	8 pin
7. Transfo 100	208 or 460V / 24V
8. Contact 100	10 amp 4 pole 208V
9. Relay 100	contactor relay 2.4-4 amp
Relay 101	contactor relay 24-32 amp
Relay 102	contactor relay 1.6-2.4 amp
Relay 103	contactor relay 4-6 amp
10. CircuitBrk 119	3 pole 3 amp
11. CircuitBrk 119	3 pole 3 amp
12. CircuitBrk 113	2 pole 1 amp
13. Block 104	line voltage block

PUMP

Part	Description
14. Relay 23	24V coil 250V
15. Timer 100	5-10 sec delay timer
16. NS Part	On / Off switch
17. Fuse 32	5 amp fuse
18. Block	8 pole block
19. Transfo 100	208 or 460V / 24V
20. Contact 100	10 amp 4 pole 208V
21. Relay 100	relay 2.4-4 amp
Relay 101	relay 24-32 amp
Relay 102	relay 1.6-2.4 amp
Relay 103	relay 4-6 amp
22. CircuitBrk 113	2 pole 1 amp
23. CircuitBrk 119	3 pole 3 amp
24. CircuitBrk 119	3 pole 3 amp
25. Block 104	line voltage block

Pump Module

Parts

Part#	Description
NS Part	5 HP chilled water pump
NS Part	7.5 HP chilled water pump
Pump 100	10 HP chilled water pump
Pump 101	15 HP chilled water pump
NS Part	20 HP chilled water pump
NS Part	25 HP chilled water pump

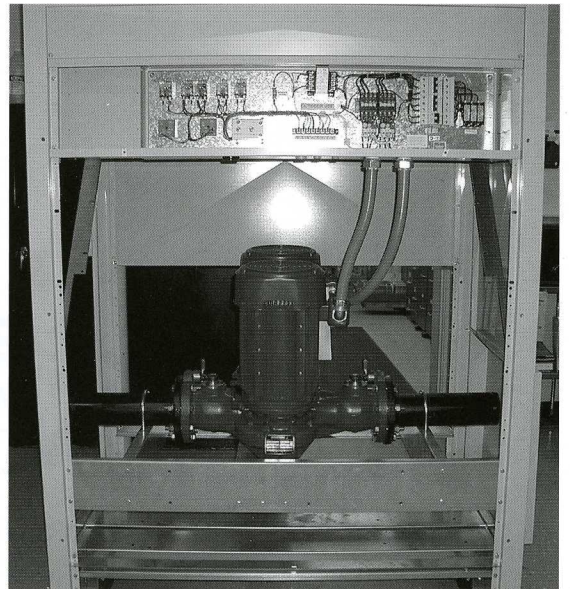

NOTE: This Parts Book contains our standard module information. Some modules may vary from the information shown here. Please call Airstack Service Department at 608-786-3400 for questions and availability.



AIRSTACK (Division of MULTISTACK)

1065 Maple Avenue

Box 510

Sparta, WI 54656

Phone 608-366-2400

Fax 608-366-2450

www.airstack.com